

BIO-CARBON OPPORTUNITIES IN EASTERN & SOUTHERN AFRICA



**Harnessing Carbon
Finance to Promote
Sustainable Forestry,
Agro-Forestry
and Bio-Energy**



CDM Capacity Development in Eastern and Southern Africa

Copyright © 2009
by the United Nations Development Programme
1 UN Plaza, New York, New York, 10017, USA

Disclaimer

The views expressed in this publication are those of the author(s) and do not necessarily represent those of the United Nations, UNDP, UNEP, UNEP Risoe Centre or their Member States.

TABLE OF CONTENTS

1.	FOREWORD	1
2.	BIO-CARBON OVERVIEW	2
	Mark Purdon	
3.	CATALYSING FORESTRY IN AFRICA: A REVIEW OF FOREST POLICY OPTIONS AND INSTRUMENTS	26
	Jeffrey Biggs	
4.	IMPLEMENTING FOREST BIO-CARBON PROJECTS: SUMMARY AND SYNTHESIS OF EXISTING CDM METHODOLOGIES FOR AR AND FOREST BIO-ENERGY	50
	Mark Purdon	
5.	BIOMASS ENERGY USAGE IN DEVELOPING COUNTRIES: AN OVERVIEW OF THE DOMESTIC SECTOR. 86	
	Mulugeta Adamu	
6.	CHARCOAL PRODUCTION: OPPORTUNITIES AND BARRIERS FOR IMPROVING EFFICIENCY AND SUSTAINABILITY	102
	Yisehak Seboka	
7.	CATALYSING BIO-ENERGY IN AFRICA: A REVIEW OF POLICY OPTIONS AND INSTRUMENTS	127
	Jeffrey Biggs	
8.	EVALUATING ANAEROBIC DIGESTER ENERGY GENERATION: OPPORTUNITIES AND BARRIERS	160
	Stephen Karekezi, Waeni Kithyoma and Oscar Onguru	
9.	EVALUATING BIOMASS ENERGY COGENERATION OPPORTUNITIES AND BARRIERS IN AFRICA: THE CASE OF BAGASSE COGENERATION	179
	Stephen Karekezi, Waeni Kithyoma and Maryanne Kamoche	
10.	BAGASSE COGENERATION IN MAURITIUS: POLICY LESSONS FOR AFRICAN COUNTRIES	208
	Prakash Deenapanray	
11.	ENVIRONMENTAL AND ECONOMIC BENEFITS OF BIOMASS FUEL USE IN CEMENT PRODUCTION	217
	Yared Haile-Meskel	
12.	BIOMASS GASIFICATION AND PYROLYSIS: OPPORTUNITIES AND BARRIERS FOR EFFICIENCY AND SUSTAINABILITY	233
	Simon Dalili	
13.	LANDFILL BIO-ENERGY: OPPORTUNITIES AND BARRIERS.....	267
	Stephen Karekezi, Waeni Kithyoma and Oscar Onguru	
14.	GLOSSARY	290

FIGURES

Figure 2-1: Global GHG abatement cost curve beyond business-as-usual – 2030	3
Figure 2-2: Carbon prices respond to the recession	4
Figure 2-3: CDM project cycle	9
Figure 2-4: Example of additional and non-additional carbon finance projects	12
Figure 3-1: Pressures on forest governance	31
Figure 5-1: Traditional three-stone stove common in households in Bangui, CAR	90
Figure 5-2: Laketch stove, Ethiopia	90
Figure 5-3: Wood-gas cookstove developed by Reed and Larson	91
Figure 5-4: Mirt fuel wood stove	96
Figure 5-5: Kenya ceramic jiko	97
Figure 6-1: Output from the transformation of 1 kg dry wood into charcoal	105
Figure 6-2: Types of charcoal kiln	106
Figure 6-3: Schematic flow diagram of agglomerated urban solid waste charcoal production	116
Figure 7-1: Bio-energy conversion processes	129
Figure 8-1: Flow diagram of a medium – large scale biogas plant.....	162
Figure 8-2: Fixed dome digester	165
Figure 9-1: Comparison of energy balances between cogeneration & separate power generation .	181
Figure 9-2: Bagasse-based BPST	182
Figure 9-3: CEST system	183
Figure 9-4: Remaining years of oil exploration	191
Figure 9-5: Summary of EOIs received: generator net output.....	199
Figure 10-1: Electricity generated in Mauritius, 1980-2007	209
Figure 10-2: Electricity generated from bagasse, 1990-2007	211
Figure 10-3: Ratio of firm to continuous power, 1997-2007	211
Figure 11-1: 2007 world energy demand by source	219
Figure 11-2: Temperature profile of pre-heating cyclones and kiln	222
Figure 11-4: Rubber tyre feeding system through bottom of pre-calcination region	228
Figure 12-1: Population without electricity, millions of people	235
Figure 12-2: The bio-refinery is analogous to today’s petroleum refinery.....	236
Figure 12-3: Principal bio-energy conversion routes and high-value products.....	238
Figure 12-4: Liquid fuels from biomass.....	239
Figure 12-5: Slow pyrolysis principle for syngas production	242
Figure 12-6: Bio-char CO ₂ sequestration.....	242
Figure 12-7: Fast pyrolysis principle for bio-oil production	244
Figure 12-8: Uses of the fast pyrolysis products.....	245
Figure 12-9: Simplified gasification system after the existing plant in Güssing, Austria	247
Figure 12-10: Syngas production through gasification of biomass & further refinement routes	248
Figure 12-11: Basic process principles for two types of steam gasification	249
Figure 12-12: Appropriate size range of different gasifiers and syngas conversion technologies	250
Figure 12-13: Possible syngas to other fuels routes	254
Figure 12-14: Crude oil and 1 st generation bio-fuel competitiveness	256
Figure 12-15: Maturity of selected biomass conversion technologies	260
Figure 13-1: Modern landfill site.....	274

TABLES

Table 2-1: Global GHG emissions in 2004.....	3
Table 2-2: Range of transaction costs for non-AR CDM projects.....	10
Table 2-3: Small-scale CDM project categories and their size limitations.....	10
Table 4-1: Approved large-scale AR and consolidated AR methodologies (July 2009)	52
Table 4-2: Approved small-scale AR methodologies and forest bio-energy methodologies (July 2009)	53
Table 4-3: Comparison of principal elements of large-scale AR methodologies	54
Table 4-4: Comparison of main elements of forest bio-energy non-AR methodologies.....	55
Table 4-5: Conditions for application of CDM AR and non-AR methodologies	57
Table 4-6: Baseline approaches for AR and non-AR CDM methodologies	60
Table 4-7: Main aspects of ex-ante baseline methodology.....	64
Table 4-8: Main aspects of ex-post monitoring methodology.....	65
Table 4-9: Main aspects of non-AR methodologies.....	76
Table 4-10: Correspondence between leakage approaches and baseline scenarios for AM0042	78
Table 4-11: Definition of renewable biomass.....	80
Table 5-1: People using traditional biomass (millions).....	87
Table 5-2: Per capita total wood consumption for energy purposes	88
Table 5-3: Estimated local employment potential of different household fuels.....	92
Table 5-4: Charcoal uses and energy loss in charcoal-making.....	93
Table 5-5: Potential energy savings in selected developing countries from improved cookstoves	94
Table 6-1: Comparison of properties of biomass used for charcoal & charcoal briquetting.....	104
Table 6-2: Semi-industrial retort-types (CCS and ICPS)	112
Table 6-3: Summary of charcoal production methods	113
Table 6-4: Estimated employment by fuel-type	123
Table 6-5: Emission rates during charcoal production & use	124
Table 7-1: Summary of biomass combustion for steam turbine power (and heat)	132
Table 7-2: Technical summary of biomass gasification	135
Table 7-3: Technical summary of anaerobic digestion	137
Table 7-4: Technical summary of alcoholic fermentation of sugarcane in Sao Paulo	139
Table 7-5: Global investment in RE by type and region.....	146
Table 8-1: Comparison of different sizes of biogas digesters.....	164
Table 8-2: Energy generation costs from various renewable energy sources.....	166
Table 8-3: Potential of biogas in Nepal.....	166
Table 8-4: Dissemination of domestic and institutional biogas systems in Asia	167
Table 8-5: Technical potential of biogas digesters in Africa	168
Table 8-6: Number of installed biogas digesters in selected countries of Africa	168
Table 8-7: Job creation potential of bio-fuels.....	170
Table 8-8: Biogas units in Kenya – key features.....	171
Table 9-1: Electrical energy efficiency	184
Table 9-2: Equipment cost of various turbines using different types of energy source.....	184
Table 9-3: Feedstock calorific values	185
Table 9-4: Global bagasse potential for cogeneration from sugarcane	186
Table 9-5: Cogeneration (bagasse) potential for Eastern and Southern Africa	187
Table 9-6: Electricity production from biomass for 8 leading countries	187
Table 9-7: Current cogeneration installed capacity in selected African countries	187
Table 9-8: Oil imports as a percentage of total imports.....	190
Table 9-9: Policies for bagasse cogeneration from Indian Government	194
Table 9-10: Incentives for the development of bagasse cogeneration in Brazil.....	194
Table 9-11: Inventory of policies supporting cogeneration in selected African Countries.....	195
Table 9-12: Energy pricing in Mauritius	199
Table 10-1: Overall conversion efficiency from solar energy to biomass of selected crops.	210
Table 11-2: World cement production by region	220

Table 11-4: Calorific values of different fuels	224
Table 12-1: Average heating values of dry wood compared to fossil fuels	236
Table 12-2: Average composition of dry wood.....	240
Table 12-3: Typical product yields obtained by different modes of pyrolysis	241
Table 12-4: Typical ranges of syngas composition for selected gasification conditions	247
Table 12-5: Electrical power production options at different scales.....	251
Table 12-6: Small scale (2 MW) biomass to electricity routes, condensing	252
Table 12-7: Small scale (2-6.2 MW) biomass to electricity routes, co-generation	252
Table 12-8: Medium scale (56-132 MW) gasification power plants, condensing.....	252
Table 12-9: Cost of electricity production in convectional condensing power plants.....	253
Table 12-10: Biomass to fuel efficiencies based on current technology	255
Table 12-11: Bio-fuel production cost in 2002 and 2030.....	256
Table 12-12: Types of market barriers.....	257
Table 12-13: Second generation bio-fuels and uncompetitive price.....	258
Table 12-14: Second generation bio-fuels and inefficient market organisation	258
Table 12-15: Second generation bio-fuels and finance risk.....	258
Table 12-16: Second generation bio-fuels and business risk.....	258
Table 12-17: Second generation bio-fuels and price distortion	259
Table 12-18: Second generation bio-fuels and regulation.....	259
Table 13-1: Comparison of different sizes of biogas digesters	269
Table 13-2: Summary of urban solid waste energy recovery technologies.....	270
Table 13-3: Estimated solid waste generation in Brazil.....	275
Table 13-4: Estimates of LFG generation and electricity generation in Africa	276
Table 13-5: Registered LFG CDM projects.	278
Table 13-6: Job creation potential for renewables.....	279
Table 13-7: Investment costs for methane gas capture and use in Conakry and Dakar	280
Table 13-8: Energy generation costs from renewable energy sources	280
Table 13-9: Output from the digestion of waste in Dar es Salaam.....	281
Table 13-10: Cost estimates for the "TAKAGAS" project.....	282
Table 13-11: TAKAGAS project economics after commissioning.....	282
Table 13-12: Typical actors in urban waste sub-sector	283

BOXES

Box 3-1: Village land forest reserves (Tanzania)	34
Box 3-2: The Ghana Timber Resources Management Act (1997).....	35
Box 3-3: Certification in Zambia.....	37
Box 3-4: Zimbabwe’s CAMPFIRE programme	38
Box 3-5: Sappi Forest Products in South Africa.....	40
Box 3-6: Fodder shrubs in Kenya	41
Box 3-7: Village Tree Enterprise Project in Burkina Faso	42
Box 4-1: The basics of ex-ante carbon sequestration estimations	67
Box 7-1: Riberalta Biomass Power Plant (Bolivia).....	132
Box 7-2: Mitigation of methane emission in charcoal production (Brazil)	134
Box 7-3: DESI Power Gasifier (India)	136
Box 7-4: Pozo Verde Farm Anaerobic Digestion (Columbia)	138
Box 7-5: Triangle Ltd (Zimbabwe) and ETHCO Ltd (Malawi).....	140
Box 7-6: Multi-functional platforms (Tanzania).....	141
Box 8-1: Small-scale biogas technologies in use in Kenya	165
Box 8-2: Why biogas projects failed in Kenya.....	173
Box 8-3: Biogas Sector Partnership (BSP) and Clean Development Mechanism (CDM).....	175
Box 8-4: Case of bio-digesters and micro loans for farmers in Cambodia.....	175
Box 13-1: Landfill CDM projects in Asia and Latin America	277
Box 13-2: Case Study: Tanzania landfill gas project.....	281
Box 13-3: South African minimum requirements for landfilling of waste*	283
Box 13-4: Bio-remediation landfills in Brazil.....	287

ACRONYMS

ACP	Africa-Caribbean-Pacific countries
ADB	African Development Bank
ADBN	Agricultural Development Bank of Nepal (Nepal)
AEPC	Alternative Energy Promotion Commission (Nepal)
AIJ	Activities Implemented Jointly
AR	Afforestation/Reforestation
BEDP	Bagasse Energy Development Programme
BFB	Bubbling Fluidised Bed gasifier
BIG/GT	Biomass Integrated Gasifier/Gas Turbine
BIG/GTCC	Biomass Integrated Gasifier/Gas Turbine Combined Cycle
BPST	Back-Pressure Steam Turbine system
BSP	Biogas Sector Partnership
BUN	Biomass Users Network
CAMARTEC	The Centre for Agricultural Mechanisation and Rural Technology
CAP	Common Agricultural Policy
CAR	Central African Republic
CBD	Convention on Biodiversity
CCS	Carbon Capture and Storage
CLEP	Commission for the Legal Empowerment of the Poor
CDM	Clean Development Mechanism
CDM EB	CDM Executive Board
CER	Certified Emission Reduction
CEST	Condensing-Extraction Steam Turbine
CFB	Circulating Fluidised Bed gasifier
CGIAR	Consultative Group on International Agriculture Research
CH ₄	Methane
CHP	Combined Heat and Power
CO	Carbon Monoxide
CO ₂	Carbon Dioxide
CO ₂ e	Carbon Dioxide Equivalent
COP	Conference of Parties
CPHEEO	Central Public Health and Environment Engineering Organisation
CTSAV	Compagnie Thermique de Savannah
DCC	Dar es Salaam City Council
DDFB	Down-Draft Fixed Bed gasifier
DME	Dimethyl Ether
DNA	Designated National Authority
EF	Entrained Flow gasifier
EGAPA	Elmirehbiba Gum Arabic Producers Association
EIA	Environmental Impact Assessment
EJ	Exajoule
EOI	Expression of Interest
EREDPC	Ethiopian Rural Energy Development and Promotion Centre

ERT	Energy for Rural Transformation programme
ESCOM	Electricity Supply Corporation of Malawi
EUA	European Union Allowances
EU-ETS	European Union – Emissions Trading Scheme
FAO	Food and Agriculture Organization
FCPF	Forest Carbon Partnership Facility (World Bank)
FDI	Foreign Direct Investment
FINESSE	Financing Energy Services for Small-scale End-users programme
FIRR	Financial Internal Rate of Return
FITs	Feed-in Tariffs
FSF	Finchaa Sugar Factory
FTL	Fischer-Tropsch Liquid
GEF	Global Environment Facility
GHG	Greenhouse Gase
GIS	Geographic Information System
GJ	Gigajoule
GPS	Geographic Positioning System
GW	Gigawatt
GWh	Gigawatt hour
HRSG	Heat Recovery Steam Generator
IBT	Improved Biomass Technology
IEA	International Energy Agency
IPCC	Intergovernmental Panel on Climate Change
IPP	Independent Power Producer
IRR	Internal Rate of Return
JI	Joint Implementation
Kcal	Kilocalorie
KCJ	Kenyan Ceramic Jiko (cookstove)
KIST	Kigali Institute of Science, Technology and Management (Rwanda)
KSC	Kilombero Sugar Company
KSW	Kinyara Sugar Works
kW	Kilowatt
kWh	Kilowatt Hour
L	Litre
I-CER	Long-term CER
LDC	Least Developed Country
LFG	Landfill Gas
LULUCF	Land-use, Land-use Change and Forestry
MA&D	Market Analysis and Development
MBFs	Modern Biomass Fuels
MDGs	Millennium Development Goals
Meth Panel	Methodology Panel (of the CDM)
MFI	Microfinance Institution
MMV	Measuring, Monitoring and Verification
MJ	Megajoule

MSIRI	Mauritius Sugar Industry Research Institute
MSW	Municipal Solid Waste
MtCO ₂ e	Mega-tonnes CO ₂ Equivalent
MTOE	Mega-tonnes Oil Equivalent
MW	Megawatt
N ₂ O	Nitrous Oxide
NAGRS	Net Anthropogenic GHG Removals by Sinks
NERD Centre	National Energy Research and Development Centre of Sri Lanka
NERSA	National Electricity Regulator of South Africa
NFFO	Non-Fossil Fuel Obligation
NIMBY	Not-In-My-Backyard
NMHC	Non-Methane Hydrocarbons
NPV	Net Present Value
NREL	National Renewable Energy Laboratory (USA)
NTFPs	Non-Timber Forest Products
O&M	Operations and Management
ODA	Official Development Assistance
OPC	Ordinary Portland Cement
OPEC	Organization of Petroleum Exporting Countries
OTC	Over-the-Counter
P.A.	Per Annum
PCBs	Polychlorinated Biphenyls
PDD	Project Design Document
PES	Payment for Environmental Services
PFB	Pressurized Fluidised Bed gasifier
PIN	Project Idea Note
PPA	Power Purchase Agreement
PRA	Participatory Rural Appraisal
PROINFA	Programme for Incentive fo Alternative Electric Energy Sources
PURPA	Public Utility Regulatory Policies Act (California)
R&D	Research and Development
RD&D	Research, Development & Demonstration
RDF	Refuse-Derived Fuel
RE	Renewable Energy
REC	Renewable Energy Credit
REDD	Reduced Emissions from Deforestation and Degradation
RIT	Registration and Issuance Team (of the CDM)
SFM	Sustainable Forest Management
SIA	Social Impact Assessment
SIEA	Sugar Industry Efficiency Act (Mauritius)
SIT	Sugar Investment Trust (Mauritius)
SNG	Synthetic Natural Gas
SNV	Netherlands Development Organization
SSA	Sub-Saharan Africa
SSC-WG	Small-Scale Working Group (of the CDM)

SSF	Savannah Sugar Factory
TANESCO	Tanzania Electric Supply Company Limited
TANWAT	Tanganyika Wattle Company
TBT	Traditional Biomass Technologies
tCO ₂ e	Tonne CO ₂ Equivalent
t-CER	Temporary CER
TJ	Terajoule
TOE	Tonne Oil Equivalent
TPC	Tanganyika Planting Company
TWh	Terawatt hour
UDFB	Up-Draft Fixed Bed gasifier
UEB	Uganda Electricity Board
UNCCD	United Nations Convention to Combat Desertification
UNFCCC	United Nations Framework Convention on Climate Change
UNDP	United Nations Development Programme
UNDP-GEF	UNDP-Global Environment Facility
USAID	US Agency for International Development
USW	Urban Solid Waste
VOC	Volatile Organic Compound
WADE	World Alliance for Decentralized Energy
WTO	World Trade Organisation

1. FOREWORD

Climate change is emerging as one of Africa's most pressing problems. The carbon market—conservatively worth \$126 billion in 2008—represents one of the most promising means of reducing greenhouse gas emissions quickly and effectively. The Clean Development Mechanism (CDM) of the Kyoto Protocol and the non-compliance (“voluntary”) carbon offset markets offer an opportunity for African countries to tap into the global carbon market, and to harness associated investment and technology flows.

Amongst the variety of mitigation and sequestration options available in the carbon markets, the “bio-carbon” sector offers significant opportunities for many non-industrialised African countries. Activities such as forestry, agro-forestry, forest preservation (“Reduced Emissions from Deforestation and Degradation”, REDD) and bio-energy offer potentially lucrative monetary opportunities from a carbon finance perspective, as well as offering sustainable development dividends. Furthermore, the rural beneficiaries of bio-carbon projects are typically unable to access the global carbon market in other ways.

Carbon credits represent an additional source of revenue for bio-carbon projects, an income stream that augments timber, Non-Timber Forest Products (NTFPs), crops, biomass fuel and other “traditional” revenue streams. Carbon credits represent a potential means of enhancing the attractiveness of the forestry, agro-forestry and bio-energy sectors as an investment destination—which, in turn, will serve to address Africa's supply-demand gap in timber and sustainable energy, and simultaneously offer significant climate change adaptation benefits.

The United Nations Development Programme (UNDP), the Food & Agriculture Organisation of the United Nations (FAO), the Riso Centre of the United Nations Environment Programme (UNEP Riso), Farm Africa and SOS-Sahel jointly organized a regional workshop in Addis Ababa in April 2009 to raise awareness amongst carbon project developers and other stakeholders of the bio-carbon opportunities offered by the carbon market, to enhance technical understanding of carbon finance, to create a “carbon community of interest” in the region, and to catalyse a bio-carbon project pipeline.

In the run-up to this workshop, UNDP commissioned a number of papers relating to specific aspects of the bio-carbon sector. This book brings together eleven of these papers, each constituting a book chapter.

The chapters are organized in terms of the production cycle, beginning with two chapters on forest bio-carbon (which can “grow” carbon): one on policy options and the second on forest bio-carbon methodologies. The book then moves into coverage of domestic bio-energy and charcoal production—technologies very much linked to the forest sector through their use of wood as a fuel source. The next chapters address bio-energy proper, first with a broad review of policy options and instruments before delving into specific bio-energy options, each with an increasing level of technological sophistication. The section begins with anaerobic digestion and then proceeds to chapters on bagasse cogeneration, biomass use in cement production, and biomass gasification and pyrolysis. The final chapter considers landfill bio-energy, at the end of the production cycle.

2. BIO-CARBON OVERVIEW

By Mark Purdon

Department of Political Science, University of Toronto

Contact: mark.purdon@utoronto.ca

2.1. INTRODUCTION

While climate change adaptation remains a priority for many African countries, the carbon market represents a promising means of reducing global emissions in a cost-effective manner while also contributing to sustainable development. The goal of the carbon market is to seek out low-cost emission reduction and removal opportunities globally in order to bring down the costs of climate change mitigation.

Amongst the variety of cost-effective global mitigation options currently available, bio-carbon offers significant opportunities for many non-industrialised African countries to participate in the carbon market. The term “bio-carbon” is defined in this context as meaning the broad sector that includes renewable energy derived from biomass and organic wastes as well as the carbon sinks (trees, vegetation, soil and peat) found in agricultural, forest and other terrestrial ecosystems. An appropriate bio-carbon policy can play an important role in mitigating climate change through:

- 1) The replacement of fossil fuel energy with renewable bio-energy;
- 2) The prevention of emissions by maintaining and enhancing current bio-carbon sinks and;
- 3) The removal of carbon from the atmosphere through the establishment of new bio-carbon sinks.

McKinsey & Company’s (2009) Global GHG Abatement Cost Curve (Figure 2-1) finds many bio-carbon options to be low-cost carbon mitigation opportunities. Some are even negative-cost (e.g., cropland nutrient management), meaning they make economic sense even without the benefit of carbon finance. Yet the ability to structure a market to realize these low-cost reductions remains a challenge. Concerns about the rigour of carbon finance as a tool for GHG mitigation and sustainable development have exerted, and continue to exert, considerable influence on international climate change policy negotiations—and, as a consequence, the bio-carbon opportunities available to Africa

Chapters in this book—written by African and international experts—discuss bio-carbon technologies and project-types in detail, including forest carbon sequestration, domestic bio-energy applications such as improved cookstoves, improved charcoal production (slow pyrolysis), anaerobic digesters for biogas production, biomass cogeneration for electricity generation and cement production, fast pyrolysis, and biomass gasification. Perhaps the most promising aspect of bio-carbon lies in the broad range of its application, from relatively small-scale household technologies to the large-scale, industrial “bio-refinery” concept.

Despite its potential, there is insufficient awareness and understanding of bio-carbon opportunities in Eastern and Southern Africa. In response, the United Nations Development Programme (UNDP), the Food & Agriculture Organisation of the United Nations (FAO), the Risoec Centre of the United Nations Environment Programme (UNEP Risoec), Farm Africa and SOS-Sahel jointly organized a regional workshop in Addis Ababa in April 2009 for carbon project developers and other stakeholders. One goal of the workshop was to enhance understanding of carbon finance, including the technical knowledge needed to implement bio-carbon projects and to navigate the administrative complexities of carbon finance—particularly with regard to additionality, non-permanence and sustainable development. This book serves to further the goals of the Addis Ababa

workshop and address the capacity gap in bio-carbon through a review of the relevant carbon finance concepts and rules, as well as emerging bio-carbon technologies and policies.

Figure 2-1: Global GHG abatement cost curve beyond business-as-usual – 2030

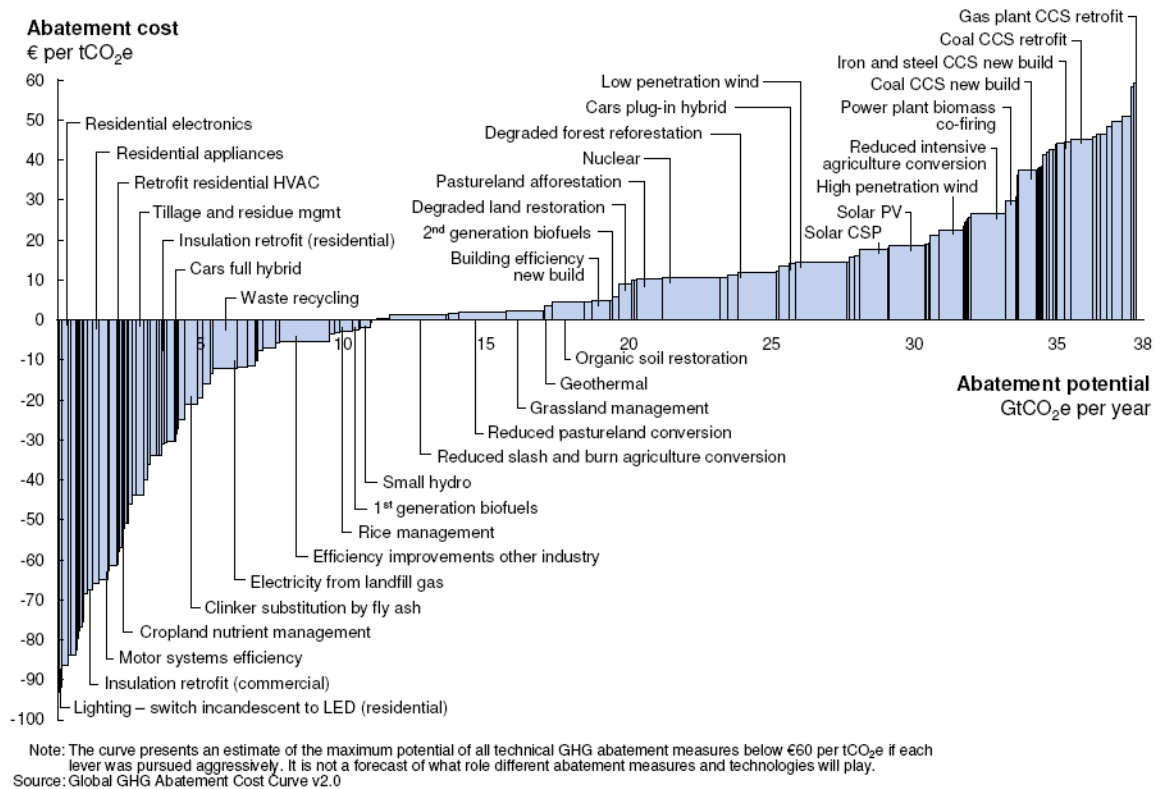

Source: McKinsey & Co. (2009)

2.1.A. STATE OF THE CARBON MARKET

The carbon market is actually comprised of many different carbon markets, each operating under their own specific rules. The size of the entire carbon market in 2008, including trade in emissions allowances and the carbon offset market, was US\$126 billion and involved the trade of 4,811 MtCO₂e (Capoor and Ambrosi 2009: 1). This represented a doubling of the size of the 2007 carbon market. The Clean Development Mechanism (CDM) of the Kyoto Protocol is the largest and most mature of the so-called carbon offset markets, though common themes and challenges also present themselves in the non-compliance (“voluntary”) carbon markets. In many ways, there are more opportunities for bio-carbon in the voluntary markets—though this may change as a result of the upcoming climate change negotiations in Copenhagen.

The CDM and voluntary markets have emerged as a significant source of development financing. The primary CDM market and voluntary markets were together worth US\$7 billion in 2008, associated with 443 MtCO₂e of emission reductions (Capoor and Ambrosi 2009: 1). If one includes the

secondary CDM market—a financial market with spot, futures and options transactions—the value of the carbon market is even larger: estimated to have been US\$33 billion in 2008.¹

The global financial crisis and questions about the future of the climate change regime have suppressed the market somewhat in 2008, when the primary CDM market contracted (Capoor and Ambrosi 2009: 32). A similar reduction occurred in the price of carbon credits (CERs—carbon credits under the CDM; EUAs—carbon allowances under the EU-ETS), which saw the primary CDM market price fall to \$10/€7 in February 2009 (Figure 2-2). While it is too early to tell definitively, there are signs that the CDM market price is now recovering.

Figure 2-2: Carbon prices respond to the recession

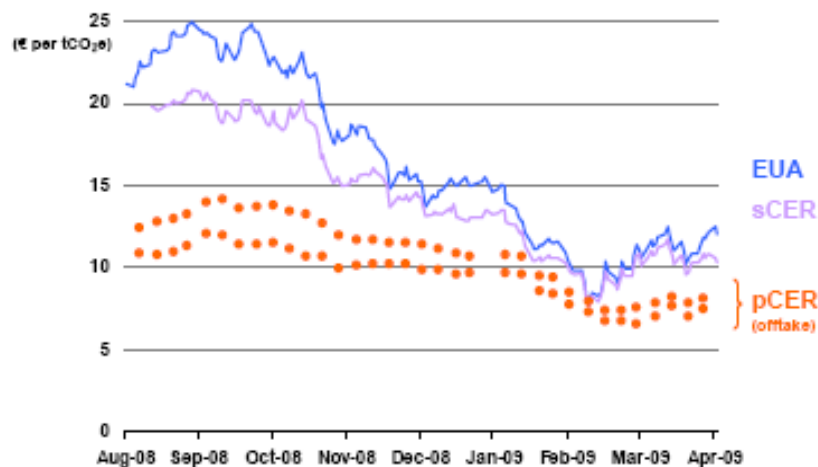

Source: Capoor and Ambrosi (2009: 6).

There is much anticipation that the upcoming climate change negotiations in Copenhagen will considerably expand the role of bio-carbon, particularly that of bio-carbon sinks. Bio-carbon sinks are currently limited to afforestation/reforestation (AR) under the CDM. Bio-carbon sink projects comprised 11% of the voluntary markets in 2008, where rules are less restrictive, but only about 1% of the CDM (Hamilton *et al.* 2007: 45, UNEP Risoe Centre 2009b). There is also growing anticipation that agreement will be reached in Copenhagen on reducing deforestation (Reduced Emissions from Deforestation and Forest Degradation, REDD), though it is not clear whether it will be included as a market-based mechanism (such as the CDM) or fund-based mechanism (Parker *et al.* 2009). There is also considerable support for the broader inclusion of agriculture, forestry and other land uses (AFOLU), which would bring into the compliance carbon market additional agricultural and soil management practices (see Terrestrial Carbon Group 2008). To understand why bio-carbon sinks have been limited in the carbon market, we need to appreciate the role of bio-carbon in the global carbon cycle.

¹ The CDM essentially consists of two markets, the primary and secondary markets. A CDM project developer generally finds a buyer on the “primary” market for credits arising from a specific project. However, this buyer does not typically use the carbon credits (CERs) for compliance purposes. Rather, many buyers in the primary market ‘aggregate’ credits from a number of different CDM projects and sell them – typically at a higher price – to firms or governments on the “secondary” market, where they are purchased for compliance purposes.

2.2. ROLE OF BIO-CARBON IN THE GLOBAL CARBON CYCLE

Based on 2004 data, deforestation, peatland degradation, forestry and agriculture were together responsible for an estimated 30% of global anthropogenic GHG emissions—equal to the release of 15 gigatonnes CO₂e (Table 2-1). The remaining GHG emissions were mostly the result of burning fossil fuels. But not all emissions make their way into the atmosphere. Currently, only about 40% of emissions remain in the atmosphere where they can contribute to climate change (Malhi 2002: 1581). The remaining 60% is absorbed and sequestered by the oceans (~21%) and terrestrial bio-carbon sinks (~39%).

Table 2-1: Global GHG emissions in 2004

	Total 2004 Emissions	
	Gt CO ₂ e	%
CO ₂ from fossil fuel combustion	27.7	56.6%
CO ₂ from deforestation, forest biomass decay and peatland degradation	8.5	17.3%
CH ₄ from waste and energy	4.3	8.7%
N ₂ O from agriculture	3.9	7.9%
CH ₄ from agriculture	2.7	5.6%
Other CO ₂	1.4	2.8%
F-gases	0.5	1.1%
Total Anthropogenic Emissions	49.0	100.0%

(Derived from IPCC 2007: Figure SPM.3)

However, the global carbon cycle is itself expected to be affected by climate change. Climate change is expected to lead to increased temperature and water stress, with the potential to reduce crop yields (Porter and Semenov 2005). Regions dependent on rain-fed agriculture, including much of sub-Saharan Africa, are particularly vulnerable (IPCC 2007a). A related concern is the effect of climate change on bio-carbon sinks, which are expected to become less efficient at absorbing CO₂ into the future (Friedlingstein et al. 2006) and could rapidly become net sources of emissions (Lenton *et al.* 2008). For example, climate change over the next century could reverse on-going carbon accumulation in tropical rainforests (Malhi 2002; Phillips *et al.* 1998), could reduce the productivity of rain-fed crops by 50% (IPCC 2007a: 13), promote further desertification of semi-arid regions (Verstraete 2008), and lead to methane releases from newly-thawed permafrost (Lenton *et al.* 2008).

So what role can bio-carbon play in the global challenge to mitigate climate change? Clearly, the principal challenge for policy-makers is to reduce emissions from fossil fuels. And the *Stern Review* has demonstrated that early action on climate change outweighs future costs (Stern 2007), particularly given the possibility of catastrophic climate change (see Weitzman 2008). Yet experience to date suggests that this is going to be more difficult and expensive than anticipated—costs and scale-up challenges continue to hamper key technologies such as carbon capture and storage (see *The Economist* 2009). Appropriate management of bio-carbon sinks can buy time for the development and adoption of technology and behavioural change necessary for such structural transformations. This makes sense as a global climate strategy because, given that CO₂ has a long residency time in the atmosphere (Archer 2009), carbon removed from the atmosphere today is worth more than future emission reductions (Keller *et al.* 2008). The sooner we remove CO₂ from the atmosphere, the better.

This assessment is at odds, however, with much of climate change policy, which has seen important limitations placed on bio-carbon sinks—in the Kyoto Protocol as well as in the EU Emissions Trading Scheme (EU-ETS). The Kyoto Protocol has placed a limit on the number of AR credits an

industrialized country can use towards its emission reduction target, has excluded deforestation from the current CDM, and has limited switching away from activities using a fuelwood baseline (see Chapter 4). The EU continues to take a “moral position” on sinks (Boyd et al. 2008: 106) which maintains that the use of credits from bio-carbon sinks in the EU-ETS is not compatible with the need for the large-scale structural transformation of the European economy for climate change mitigation (see Wemaëre 2009; EU Directive 2009/29/EC).

These positions certainly have merit because emissions from fossil fuel consumption continue to rise—increasing the risk of climate change and of bio-carbon sinks turning into future emission sources. However, the sheer scale of bio-carbon mitigation potential, combined with its generally low cost and the environmental and developmental ‘co-benefits’ that typically accompany bio-carbon projects, might be reason to reconsider policies towards the bio-carbon sector.

2.3. HISTORY OF BIO-CARBON IN UN CLIMATE CHANGE NEGOTIATIONS

The CDM is the largest and most mature carbon offset market currently in operation. While limitations on bio-carbon in the Kyoto Protocol and EU-ETS described above have moved many bio-carbon activities into the non-compliance (“voluntary”) carbon markets, there are signs that this might change in the post-2012 period as a result of upcoming negotiations in Copenhagen.

2.3.A. THE CLEAN DEVELOPMENT MECHANISM: THE KYOTO “SURPRISE”

The CDM grew out of a proposal from Norway at the initial 1992 UNFCCC session calling for a global GHG credit trading scheme, culminating in the adoption of the mechanism called Activities Implemented Jointly (AIJ) at the 1995 Conference of Parties (COP) to the UNFCCC (Eyzaguirre and Kalas 2002). When the COP was again convened in 1997 (in Kyoto, Japan) there was a sense of dissatisfaction with the AIJ, particularly in terms of the limited benefits accrued to non-industrialized countries as well as the administrative costs for verifying and monitoring GHG credits. This led to a proposal from Brazil for a Clean Development *Fund* (Gupta 2000; Werksman 1998) which would be distinct from AIJ. According to the Clean Development *Fund* idea, industrialized countries that failed to meet their emission reduction targets under the Kyoto Protocol would be required to pay a fine into the fund. This money would then be used for climate mitigation and adaptation projects in developing countries.

The Clean Development *Mechanism* (CDM) that was finally negotiated came, then, as something of a surprise in the late hours of negotiations (Werksman 1998). It might be seen as a compromise solution between the AIJ and Clean Development Fund. The CDM maintains the GHG trading mechanism of the AIJ program, but also requires that any CDM project assist the host country attain sustainable development. As a result of these negotiations, the CDM has the “twin goal” of promoting sustainable development in project host countries and mitigating climate change. This is clearly expressed in paragraph 2 of Article 12 of the Kyoto Protocol:

“The purpose of the clean development mechanism shall be to assist Parties not included in Annex I [non-industrialized countries] in achieving sustainable development and in contributing to the ultimate objective of the Convention, and to assist Parties included in Annex I [industrialized countries] in achieving compliance with their quantified emission limitation and reduction commitments under Article 3.”

This “twin goal” distinguishes the CDM from the other flexibility mechanisms—Emissions Trading and Joint Implementation—which do not have the notion of sustainable development as clearly incorporated.

2.3.B. LIMITATIONS ON BIO-CARBON IN THE CDM

The role of bio-carbon sinks in the climate change regime has become one of the most contentious issues discussed by the Parties. The role forests should play nearly ruined climate change negotiations at the 2000 Sixth Conference of Parties (COP6) of the UNFCCC and forced an extraordinary COP6b in early 2001 (Doelle 2005; Fearnside 2001; Niles 2002; Wirth 2002). The decisions made at COP6b, however, came to limit in an important way the role of bio-carbon sinks in the CDM.

The most important decision regarding bio-carbon sinks was to exclude efforts to reduce deforestation, improve forest management and enhance soil sequestration from the CDM. The only bio-carbon sink permitted in the CDM is afforestation/reforestation (AR). Yet important limitations have also been placed on AR: a cap was placed on the number of credits that developed countries (Annex I countries, in the terms of the Kyoto Protocol) could generate through CDM AR projects, limited to 5% of a country's 1990 baseline emission levels in the first commitment period, 2008-2012 (UNFCCC 2001: para 7(b)). One estimate of the total amount of carbon this represents is 110 Mt CO₂e (Bernoux *et al.* 2002: 380). A further delay has resulted from difficulties of integrating credits from AR CDM projects into the European carbon market, which has excluded the expiring CER credits (t-CERs and l-CERs) generated by CDM AR credits (Schlamadinger *et al.* 2005)—recent EU decisions maintain this exclusion (Wemaëre 2009). Related to the exclusion of deforestation from the CDM is the issue of non-renewable fuelwood. As described in more detail in Chapter 4, CDM projects using non-renewable fuelwood as a baseline (such as for improved cookstove projects) were ineligible until 2007.

Why have bio-carbon sinks been limited? First, carbon credits issuing from avoided deforestation were expected to flood the carbon market with cheap credits. Economic modelling has suggested that the introduction of avoided deforestation into the market might suppress the price of carbon credits by as much as 62% (Jung 2003: 16-17) and would also divert resources away from renewable energy projects (Jung 2005: 94). Second, there have been concerns with the permanence of bio-carbon sinks. Trees, vegetation and soils are at risk of releasing their carbon back into the atmosphere pending disturbance, senescence or mortality—adding another layer of complexity to carbon accounting (see Galik and Jackson 2009; Schlamadinger *et al.* 2007). This becomes only more of a challenge because, as mentioned earlier, bio-carbon sinks may themselves be vulnerable to climate change-driven “reversal” or degradation in the future—becoming emission sources.

Third, there have been concerns associated with sustainable development, human rights and land governance. There have been instances where local peoples have been displaced as a result of forest carbon offset projects (Lang and Byakola 2006; Lohmann 2006: 222-274; Orlando *et al.* 2002). The concern here is that the international carbon market only replicates international systems of exploitation: “CO₂lonialism” (Forsyth and Young 2007). While the risk of expropriation of the assets of rural peoples in developing countries through either AR or forest conservation efforts is real, it is worth noting that this is, unfortunately, not restricted to carbon offset projects (see Brockington 2007). Other problems linked to sustainable development arise where forest plantations or biomass crops replace existing native ecosystems, which can lead to a host of problems including depleted water resources and changes in biodiversity (World Rainforest Movement 2002).

2.3.C. CDM VS REDD VS VOLUNTARY MARKET VS ALTERNATIVES

While the CDM is important, it is by no means the only outlet available to bio-carbon project developers. Here we briefly discuss alternatives to the CDM for accessing carbon finance for bio-carbon activities.

Some of the limitations on bio-carbon sinks in the CDM discussed above are now being addressed under the REDD initiative for the post-Kyoto period (Forner *et al.* 2006; IISD 2009; Parker *et al.* 2009) or have been circumvented in the voluntary carbon market (Hamilton *et al.* 2009: 45). REDD was brought back into the UN climate change negotiations through an initiative of the Governments of Papua New Guinea and Costa Rica (2005) to reconsider deforestation in the UN climate change regime and became an integral part of the Bali Action Plan adopted in 2007 (UNFCCC 2007a: para.1(b)(iii); 2007b). The discussion on REDD, however, continues to be one of its over-arching architecture, particularly whether to link REDD directly to the carbon market. At the time of writing, no methodology for REDD had been approved by the UN, though a proposal has recently been made to the Voluntary Carbon Standard (VCS), whose methodologies share many similarities with CDM methodologies.

The non-compliance “voluntary” markets have been a key area for innovation in the bio-carbon arena, particularly with regard to AR projects which dominated the voluntary markets until 2004. However, as the voluntary markets have expanded, the share of AR projects has decreased from 29% in 2004 to 16% in 2008 (Hamilton *et al.* 2009: 44-45). At the same time, certain voluntary market operators—most notably the Gold Standard—have not permitted AR projects. It should also be noted that only in 2008 did renewable biomass cookstove projects become viable under the Gold Standard (Gold Standard 2008). More recently, the VCS has attempted to standardize carbon accounting procedures both under the CDM and other compliance systems. While no VCS approved methodologies exist for AR other than those already in use under the CDM, guidelines have recently been issued for VCS AFOLU bio-carbon projects, with important provisions for non-permanence including carbon buffers as well as a risk analysis system (VCS 2008).

The above alternatives represent variations on the project-based emissions regulation system initiated under the CDM. An alternative that departs from this design is worthy of mention. This is the bio-carbon trading system proposed by the Terrestrial Carbon Group (2008), which resembles an emission allowance system. Under this system, each participating country would conduct a detailed inventory of national bio-carbon sinks and then distribute or auction rights to emit bio-carbon to private individuals or, quite plausibly, communities. Private individuals or communities would then be free to sell these rights to emit to foreign companies, effectively as bio-carbon emission allowances.

2.4. TECHNICAL ASPECTS OF BIO-CARBON – SOME COMMON THEMES

2.4.A. CDM ADMINISTRATION AND PROJECT CYCLE

The first step in the CDM project cycle is **(1) Project Design**, which entails the development of a PIN prior to the development of the more detailed Project Design Document (PDD). The PDD must be based on an approved CDM baseline and monitoring methodology. A methodology for the environmental and socio-economic assessment of a CDM project’s impact is not prescribed in the approved methodologies. Rather, these issues are to be addressed on a case by case basis in the PDD, where it is required as Section E-*Environmental Impacts*, Section F-*Socio-Economic Impacts* (CDM AR projects only) and Section G-*Stakeholder Comments*, and as per the approval process of the host country’s Designated National Authority (DNA).

Upon completion, the draft PDD is sent to the host country’s DNA for **(2) National Approval**. This entails an evaluation of whether a project will mitigate GHGs and whether the proposed project meets the nationally-determined criteria for sustainable development. National approval comes in the form of a Letter of Approval being granted by the DNA. Also at this stage, project proponents are required to seek stakeholder comments, which are incorporated into the finalized PDD. If approved

by the DNA, the finalized PDD, including the DNA’s Letter of Approval and the stakeholder comments, is passed on for **(3) Validation**.

Figure 2-3: CDM project cycle

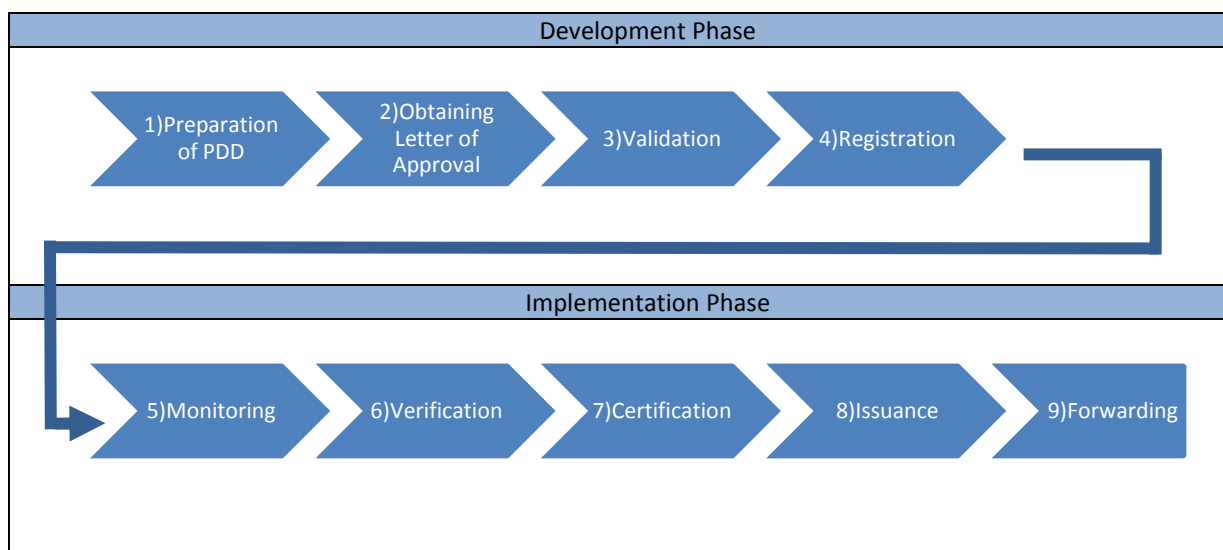

Validation is performed independently by a third-party Designated Operational Entity (DOE) in order to assess if all the components of the PDD are satisfactory, including the Letter of Approval from the DNA. The DOE is required to make the validated project available for stakeholder comments for a 30-day period on the UNFCCC website. If successful, the project is then passed on to the CDM Executive Board (CDM EB) for **(4) Registration**. The CDM EB appoints a Registration and Issuance Team (EB-RIT) to appraise the request for registration. This appraisal should be achieved within eight weeks, after which time the project is deemed registered on the UNFCCC website.

With the PDD registered, a CDM project can then be officially implemented. In order to ensure the project meets the conditions of the PDD, it requires **(5) Monitoring**. This entails the systematic review of net GHG removals achieved during the course of the project. Monitoring results are inspected periodically by a second DOE during the course of the CDM project’s crediting period: **(6) Verification**. It should be noted that for normal CDM projects, a second DOE—a different DOE than the one that validated the project—is required for verification. The next step is **(7) Certification**, when the DOE submits a formal written confirmation that the emission reductions set out in the verification report were actually achieved, constituting a request for **(8) Issuance** of the carbon credits (Certified Emission Reductions, CERs) by the CDM EB. Up until this point, the actual carbon credits—CERs—do not exist; they are a commodity issued only by the CDM EB. There may be more or fewer carbon credits issued than originally envisioned in the PDD: the number of CERs issued is dependent on actual project performance, as captured by the monitoring and verification regime. The last step is **(9) Forwarding**, when the CDM registry administrator transfers CERs from the CDM EB’s pending account into the accounts of the project participants.

2.4.B. TRANSACTION COSTS IN THE CDM

The complicated project cycle for the CDM has made transaction costs a real issue. Total transactions costs have been estimated to lie in the range of approximately US\$50,000 to \$200,000 for large-scale projects (Table 2-2). One of the earlier observations of the CDM was that the high transaction costs involved in CDM project administration would tend to favour large-scale projects (Michaelowa and Jotzo 2005).

Table 2-2: Range of transaction costs for non-AR CDM projects

	Low	Average	High
Large-Scale CDM			
Project Preparation Costs	\$43,000	\$118,000	\$193,000
Project Implementation Costs	\$5,000	\$12,000	\$19,000
Total Costs	\$48,000	\$130,000	\$212,000
Small-Scale CDM			
Project Preparation Costs	\$24,500	\$38,500	\$52,500
Project Implementation Costs	\$5,000	\$12,000	\$19,000
Total Costs	\$29,500	\$50,500	\$71,500

Source: Pin (2005)

There have been two main approaches to reducing the transaction costs of the CDM. The first attempt was to simplify the CDM administrative process for small-scale projects, most notably through predefined and simplified methodologies and the bundling of discrete project activities (UNFCCC 2002). Such provisions have tended to bring transaction costs down to range of approximately \$30,000 to \$70,000 (Table 2-2) for so-called small-scale projects. Small-scale projects are, however, limited in size: a maximum of 60,000 tCO₂e per year for energy projects and 16,000 tCO₂e per year for AR projects (UNFCCC 2006: para. 28; UNFCCC 2007c). The different small-scale CDM project categories and their size limitations are presented in Table 2-3 below.

Table 2-3: Small-scale CDM project categories and their size limitations

AMS I	Renewable energy	Project activities with a maximum output capacity equivalent of up to 15 MW
AMS II	Energy efficiency	Project activities which reduce energy consumption, on the supply and/or demand side, by up to 60 GWh per year
AMS III	Other project activities that reduce anthropogenic emissions by sources	Directly emit less than 60,000 tCO ₂ e per year
AR-AMS	Afforestation/Reforestation	Project activities sequestering up to 16,000 tCO ₂ e per year

The response to the small-scale project modality has, however, been rather mute. While the total number of large-scale and small-scale CDM projects is comparable, small-scale projects are expected to account for only about 10% of all CERs generated by 2012 (UNEP Risoe Centre 2009b).

A more recent attempt to manage transaction costs is “programmatic” CDM, which builds on the bundling concept of small-scale projects but, in effect, removes the size limitation (UNFCCC 2005b: para. 20)—an issue to which we return because it might address other system issues confronting the CDM.

2.4.C. FINANCING CDM PROJECTS

Transaction costs introduce the issue of project finance. The costs of a CDM project can be significant and it is necessary to justify such expenditures. Many carbon projects rely upon a number of revenue flows (in some cases, multiple carbon revenues), with the “carbon layer” typically representing just one source of project revenue, and often the lesser one (Black 2009).

What is vital is sound financial planning. A project proponent should have a clear understanding of the expected financial returns from the project, how much the project is anticipated to cost, and how much the project proponent can finance from internal sources (and thus how much remains to be funded via external sources). These external sources may include foundations, equity providers and lenders. Detailed financial projections will enable the project proponent to calculate a project's funding requirements and communicate this to potential financiers.

There are some obvious advantages associated with carbon finance. Future carbon revenue flows can be used as collateral for obtaining loans from financial institutions, though this option is still difficult in Africa. Future carbon credit flows can also be used to negotiate forward payment from the carbon buyer. This up-front payment can then be used to pay for project establishment costs. However, caution is in order. Carbon finance is insufficient to address many of the underlying financial constraints that hold back development projects in Africa. As the World Bank (de Gouvello *et al.* 2008: 173) has observed: "Carbon funds provide neither equity nor investment financing for the underlying project...in most cases, carbon finance would provide only a limited share of the cash flow expected by clean energy projects. Thus, the core issue of how to finance the region's clean-energy infrastructure investments remains."

2.4.D. BASELINES & ADDITIONALITY

Additionality is perhaps the most important aspect of carbon finance as it ensures that carbon credits generated represent genuine emission reductions or, in the case of bio-carbon sinks, emission removals. Additionality is defined as follows in the CDM:

A CDM project activity is additional if anthropogenic emissions of greenhouse gases by sources are reduced below those that would have occurred in the absence of the registered CDM project activity (UNFCCC 2005d: para.43).

The crux of the additionality concept revolves around the hypothetical baseline scenario. The baseline is defined as the scenario that reasonably represents emissions or emission removals by sinks that would have occurred in the absence of the CDM. Accreditation for a CDM project can only occur if the emissions reduced or removed over the course of a project activity are in *addition* to this baseline scenario. The moral hazard here should be obvious: there is temptation to select a baseline scenario against which the CDM project appears additional. As a result, credits might be granted for projects that would have been implemented anyway—bogus "anyway credits" (Wara 2008). This has formed the basis of many of the current criticisms of carbon finance (Lohmann 2006; Schneider 2007; Wara 2008; Wara and Victor 2008). In response to these concerns, the CDM Methodology Panel has suggested tightening the rules for CDM projects that have potentially high profitability even without carbon finance (CDM Meth Panel 2008). How, precisely, additionality might be reformed remains a matter of discussion.

The additionality problem can be broken down into two components. First, there are information asymmetries in the regulation of additionality (Wara and Victor 2008). Basically, project proponents know a lot more about a proposed carbon project than a third-party regulator (DOE) or the CDM Executive Board. DOEs are often brought in from Europe or North America, though there are ongoing efforts to develop African verifiers as part of the Nairobi Framework for catalyzing the CDM in Africa.² It is possible that the discernment of qualitative, context-dependent claims of a project's additionality might be over-looked by such 'outside' DOEs.

² http://cdm.unfccc.int/Nairobi_Framework/elements/index.html

The other issue is a temporal one: the credibility of a project baseline is only as good as its projection into the future. Things change over time and a project which appears additional at a project's inception may not remain so over the entire crediting period. CDM projects adopt a baseline approach that permits the project developer to "freeze" the baseline identified at the start of the project over the entire crediting period. This is presented in Figure 2-4. However, such a "frozen" baseline might not always be appropriate.

When discussing baselines, one also needs to be clear about how long into the future projections are being made. This is related to the choice of crediting period: that is, to the period over which a CDM project can generate officially-recognised CERs. For non-AR CDM projects, the crediting period is 7-years (up to twice renewable) or a single 10-year period. For AR CDM projects, the crediting period is 20 years (up to twice renewable) or a single 30-year period.

Figure 2-4: Example of additional and non-additional carbon finance projects

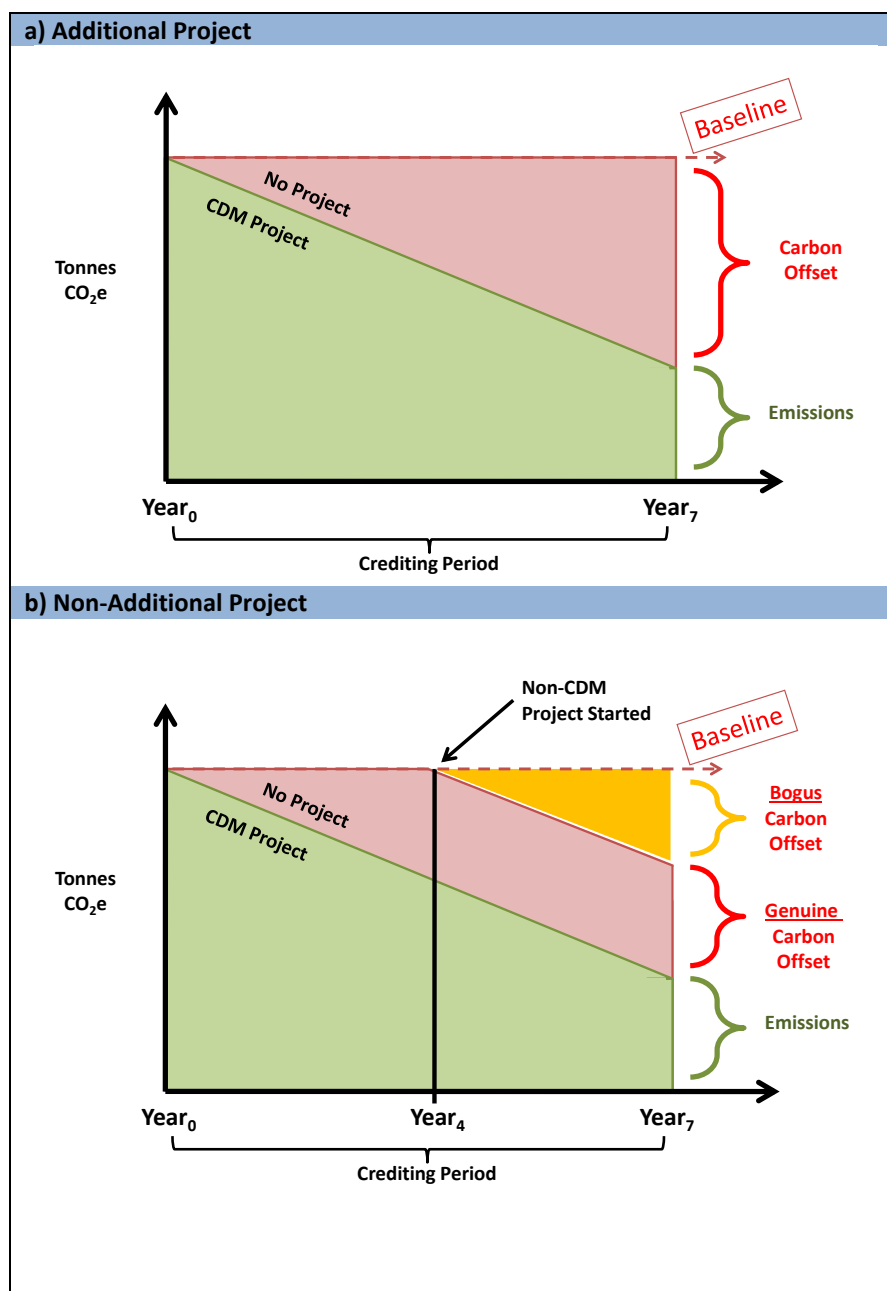

2.4.E. MEASUREMENT, MONITORING AND VERIFICATION

Measurement, monitoring and verification (MMV) present considerable challenges for bio-carbon projects. Victor (2001) has long argued that any economic efficiency gains associated with carbon trading would be undermined by the costs of measuring, monitoring and verifying carbon transactions. Without effective MMV it is simply difficult to know what is being traded. Yet efforts to standardize MMV have come a long way in recent years.

In terms of measurement, the most important developments have been approved CDM methodologies. These methodologies present standardized approaches to undertaking a carbon finance project, including the measurement of emissions and carbon pools in baseline and project scenarios. Many of the methodologies are derived from technical guidelines for GHG inventories prepared by the IPCC. In terms of bio-carbon, these have evolved from a focus on land-use, land-use change and forestry (LULUCF) in previous versions (IPCC 1996; 2003) to the most current 2006 guidelines which consider bio-carbon more comprehensively as AFOLU (IPCC 2006). While there is often concern about the precision of bio-carbon measurements, the approach adopted by the IPCC has been to use a conservative approach. This applies to both parameters used in calculations as well as statistical approaches, such as the Reliable Mean Estimate (RME). RME uses not the mean but the lower boundary of the mean's confidence interval as the measurement value that can be credited. Such approaches are intended to systematically under-estimate carbon credits generated through bio-carbon projects and hence "err on the side of caution".

Monitoring and verification are related concepts. Monitoring is generally undertaken by project developers themselves and there are elaborate rules described in the CDM methodologies about exactly what, and how, emissions and carbon pools need to be monitored over the course of a project's crediting period. Because self-monitoring represents a clear moral hazard, third-party verification is required. Verification refers to the process of independently checking the accuracy and reliability of reported information under monitoring or the procedures used to generate such information. These third-party verifiers are referred to as Designated Operational Entities (DOEs), generally represented by accounting and technical firms. Since 2008, DOEs have been required to follow the *CDM Validation and Verification Manual* (CDM EB 2008) with the intention that this will promote quality and consistency in CDM validation/verification reports. However, Wara & Victor (2008) point out misaligned incentives between project developers and DOEs—who are paid by project developers themselves—and suggest a need to shift payment for third-party verification services to the CDM EB. It remains to be seen if such reforms will be made to the CDM administrative structure.

2.4.F. NON-PERMANENCE

The problem of non-permanence results from disturbance, senescence or mortality of bio-carbon sinks, a problem that may be exacerbated by future climate change. In the CDM, the potential non-permanence of AR projects has been addressed by stipulating that all AR CDM credits (I-CERs and t-CERs) are temporary credits which expire after a certain period of time (Schlamadinger et al., 2007). Such credits are, in effect, temporary leases on carbon reductions, underlain by an assumption that the carbon will be eventually re-emitted into the atmosphere.

The VCS (2008) addresses the non-permanence issue in a different way, by devising a buffer and risk management system for AR and other bio-carbon sink projects. This system requires that individual projects maintain adequate buffer reserves of non-tradable carbon credits to cover unforeseen losses in carbon stocks. The number of buffer credits that a given project must maintain is based on a risk assessment of the project's potential for future carbon loss. However, the buffer credits from *all* projects are held in a single AFOLU Pooled Buffer Account with the intention that there is always

a net surplus of carbon in the overall buffer despite individual carbon losses. As a result, the VCS claims that carbon credits are permanent and fully fungible with other credits.

Mention should also be made of the “tonne-year” approach (Moura-Costa and Wilson 2000). This observes that CO₂ emitted into the atmosphere has a finite residence time there, after which it is re-absorbed by sinks in the global carbon cycle. If carbon is sequestered in biomass for a length of time equivalent to or longer than CO₂'s atmospheric residence time, then it is as good as a permanent reduction. If this so-called “equivalence time” is 55 years, as suggested by Moura-Costa and Wilson (2000), then 1 tonne of CO₂ stored for 55 years is equivalent to a one tonne permanent reduction. Conversely, 55 tonnes of CO₂ stored in biomass for one year is considered equal to a one tonne permanent reduction. For a number of reasons, mostly due to uncertainties in assessing CO₂ residence times—particularly given anticipated decreasing efficiency in the global carbon cycle's absorptive capacity (Friedlingstein *et al.* 2006)—the approach was not adopted in the CDM (Maréchal and Hecq 2006).

2.4.G. LEAKAGE

Leakage is the increase in emissions outside the boundary of a carbon project area that is attributable to the project. Leakage is often perceived as a greater issue for bio-carbon sink projects because such projects require a disruption of the previous land-use activity, which then may shift to other areas (Dutschke *et al.* 2006). Approved CDM methodologies all denote ways of accounting for leakage.

As explored in more detail in Chapter 4, leakage is accommodated in the CDM methodologies by estimating emissions from activities that might be displaced outside the project area such as grazing, clearing land for crops and fuelwood collection. These leakage provisions are then subtracted from any carbon gains resulting from the project itself, functioning as something of a buffer. In practice, however, the boundaries of a bio-carbon project (and thus measurement of activities that might be displaced outside it) are often fuzzy, if not unknown, to local inhabitants. A sensible project management approach would typically go beyond the purely technical provisions for leakage and additionally engage rural communities in participatory planning efforts so as to reduce leakage risks.

Other leakage risks include market risks, associated with REDD or improved forest management (not included in the CDM but currently being discussed for inclusion in the post-2012 period). The risk here is that the activities could lead to a potential reduction in the flow of timber off the site, thereby causing leakage through the displacement of logging activity to other forest areas. The VCS requires that this leakage be accounted for using the leakage table provided in its “Tool for AFOLU Methodological Issues”.

Other ideas for managing leakage include the systematic assessment of a reference area around the project area, from which leakage would be evaluated (Dutschke *et al.* 2006). The reference area is a land unit used to reflect the baseline land use without the bio-carbon project. The challenge here lies in determining whether increased emissions in the reference area are attributable to displaced activities originating from the bio-carbon project or resulting from forces further removed—the larger “political influence area”.

2.4.H. PROGRAMMATIC CDM: SYSTEMIC PROBLEMS REQUIRE A SYSTEMIC SOLUTION

A more recent attempt to manage transaction costs is “programmatic” CDM, which builds on the bundling concept of small-scale projects but implicitly removes the size limitation (UNFCCC 2005b: para.20). Here an unlimited number of CDM projects, often from different locations, are coordinated under the same umbrella project by a single project manager—denoted as the “coordinating entity”.

A programme of activities (PoA) is defined as a coordinated action by a public or private entity which leads to the implementation of a (potentially large) number of CDM programme activities (CPAs), which in turn lead to emission reductions (ERs) or net anthropogenic GHG removals by sinks (NAGRS). The PoA is something of a meta-CDM project comprised of an unlimited number of CPAs.

While programmatic CDM aims to reduce transaction costs and enhance the flexibility of multi-site projects, it may also prove an intermediate step towards 'sectoral CDM' and allow systemic issues confronting the current project-based CDM arrangement to be addressed. Systemic challenges faced in the CDM are non-permanence, leakage and additionality. In terms of non-permanence, sectoral CDM lends itself to a systematic buffer and risk analysis system similar to that envisioned now by the VCS. Sectoral CDM might also improve the management of leakage because the entire sector (or land-area) would be considered part of a contiguous mitigation effort, including monitoring, not just specific project areas.

Last, sectoral CDM may also alleviate the information asymmetries involved in assessing the additionality of individual CDM projects (Wara and Victor 2008). At least in theory, sectoral CDM would allow regulators to scan across an entire industrial sector to better evaluate whether an individual activity meets a pre-determined "additionality" threshold.

2.5. BIO-CARBON, SUSTAINABLE DEVELOPMENT AND LOCAL COMMUNITIES & INDIGENOUS PEOPLES

Despite explicit mention of sustainable development to the CDM, there are concerns that the CDM is under-delivering on its promise. On the one hand, the distribution of CDM projects continues to be skewed towards emerging economies such as China and India, with Africa representing less than 1% of total carbon credits generated under the scheme (Cosbey *et al.* 2005; UNEP Risoe Centre 2009a; UNFCCC Secretariat 2008). This is due to capacity constraints and governance issues in Africa, as well as the limitations on bio-carbon sinks described earlier.

But the distribution of CDM projects is not the only concern. Currently, assurance that a CDM project contributes to sustainable development is made by the government of the country hosting the project. There has been no attempt to standardize the definition of sustainable development, leaving it to be defined by host governments themselves. Many have responded by publishing sustainable development criteria. Yet there continue to be concerns about the sustainable development impact of existing CDM projects (Gundimeda 2004; Olsen 2007; Olsen and Fenhann 2008).

One recurring theme of sustainable development is decentralization and local management of natural resources, championed since the Bruntland Commission (WCED 1987). Community-based natural resource management, such as community forests, has often been proposed as a sustainable rural development strategy because local communities have a vested interest in the sustainability of local natural resources (Gibson *et al.* 2000; Purdon 2003; Wily 1999; World Bank 2004).

Though recent research suggests that the capacity of communities to manage local natural resources should not be romanticized (Agrawal and Gibson 1999; Ribot *et al.* 2006), there is an emerging consensus that involving local communities and Indigenous Peoples in bio-carbon projects is key. Indeed, evidence suggests that community forests are already managing substantial carbon reserves (Murdiyarto and Skutsch 2006; Purdon 2008). Involvement of local communities and Indigenous Peoples not only promotes human rights and social justice but is also often necessary to make the implementation of bio-carbon projects possible.

2.5.A. RESPECTING THE RIGHTS OF LOCAL COMMUNITIES AND INDIGENOUS PEOPLES

Often, the traditional livelihood practices of local communities and Indigenous Peoples is conducive to bio-carbon projects, particularly those seeking to preserve existing bio-carbon sinks. Under such conditions, it would be appropriate to ensure that the communities involved receive a share of the benefits of carbon finance. But there may also be reasons that a local community opposes a bio-carbon project. It is important to devise appropriate institutional mechanisms to accommodate better the rights of local communities and Indigenous Peoples.

One straightforward approach is to ensure that a portion of the rights to carbon credits generated is allocated to the communities involved. But various other models are possible (K:TGAL 2009). Countries may decide to distribute benefits internally on the basis of effort or input, rather than output (of carbon savings). Benefits might also be distributed in kind rather than in financial forms. Realizing the equitable distribution of benefits to local communities and Indigenous Peoples may, however, require significant changes to land tenure and legal regimes in host countries, particularly where communities have use rights but not ownership rights of local natural resources.

Land tenure is something to which the climate change regime is really only beginning to turn its attention in the context of REDD (see SBSTA 2008: Annex II para.7(e); SBSTA 2009: Annex preamble and para.3). It is worth pointing out, however, that community land rights are explicitly recognized in the UN Declaration on the Rights of Indigenous People (Gilbert 2007), as well as in the provisions of the UN Convention on Biodiversity (CBD) and the UN Convention to Combat Desertification (UNCCD) (Oba *et al.* 2008). UNDP's new Commission for the Legal Empowerment of the Poor (CLEP) has also stressed the importance of land tenure security for rural development (CLEP 2008).

2.5.B. LOCAL COMMUNITIES AND BIO-CARBON IMPLEMENTATION

Independent of human rights and social justice concerns, local communities and Indigenous Peoples have also much to offer towards the successful implementation of bio-carbon projects. Often undertaken in rural areas where access and communication is difficult, bio-carbon implementation and monitoring is a concern. Yet these are similar issues that forest researchers have wrestled with over recent years, where it has been learned that the involvement of local communities can be a cost-effective strategy for sustainable forest management (Gibson *et al.* 2000; Kant 1999; Kant and Barry 2001).

In terms of community involvement in bio-carbon projects, one idea is to provide assistance to local communities and indigenous peoples in order that a portion of project implementation and monitoring be assigned to them (Murdiyarso and Skutsch 2006), though emphasizing the importance of adequately and fairly compensating community work (Cooke and Kothari 2001). Another theme is to adequately involve communities in project design so as to avoid potential land-use conflicts, particularly with regard to access to lands for food security and fuelwood.

While it is unlikely that sufficient skills and resources for fully implementing CDM bio-carbon projects will be available amongst individual rural communities (Minang *et al.* 2007), a network of communities brought together into a programmatic CDM scheme may allow for the appropriate allocation of rights and responsibilities between the communities involved and the project developer. In this light, local communities could become true partners in the implementation of bio-carbon projects.

2.6. SUMMARIES OF BOOK CHAPTERS

This book brings together eleven papers commissioned by UNDP to address different aspects of bio-carbon as it presents itself in Eastern and Southern Africa. The chapters are organized in terms of the production cycle, beginning with two chapters on forest bio-carbon (which can “grow” carbon): one on policy options and the second on forest bio-carbon methodologies. The book then moves into coverage of domestic bio-energy and charcoal production—technologies very much linked to the forest sector through their use of wood as a fuel source. The next chapters address bio-energy proper, first with a broad review of policy options and instruments before delving into specific bio-energy options, each with an increasing level of technological sophistication. The section begins with anaerobic digestion and then proceeds to chapters on bagasse cogeneration, biomass use in cement production, and biomass gasification and pyrolysis. The final chapter considers landfill bio-energy, at the end of the production cycle. The distinguishing feature of urban solid waste in Africa is its high organic content, and so urban solid waste can legitimately be considered a ‘bio-carbon’ issue.

Brief overviews of the specific chapters are provided below.

Chapter 3, by Jeffrey Biggs, observes that sub-Saharan Africa’s failure to attract carbon finance in general—but specifically CDM afforestation/reforestation (AR) projects—can be found in the region’s socio-economic, political and regulatory environment. He explores this enabling environment with a discussion of the conditions needed for a successful forestry business model and the regulatory framework for sustainable forest management (SFM). The forestry business model is found to be shaped by competition in supply, competition in land-use and competition between property rights regimes. The emerging regulatory framework for SFM promotes market-like instruments, decentralization towards community management and greater participation in governance. Within this enabling environment, a number of policies are identified—each with its strengths and weaknesses—including tenure reform, legislative reform, forest certification, payment for ecosystem services (PES), community-corporate partnerships, agroforestry and non-timber forest product based (NTFP-based) rural development—any among which might be linked to carbon finance. However, any SFM policy and associated funding source becomes significantly more complex when considered in the CDM context.

Chapter 4, by Mark Purdon, summarizes the key points of current CDM forestry methodologies, as of July 2009. It discusses technical and administrative issues for eleven large-scale AR methodologies as well as six small-scale AR methodologies. In addition, two small-scale non-AR methodologies involving “non-renewable biomass” are discussed because of their application in improved cookstove projects where the project baseline scenario is fuelwood. Finally, two non-AR large-scale forest bio-energy methodologies are presented, one involving charcoal production and the other fuel-switching to woody biomass. The chapter concludes that we can expect to see the UNFCCC continue to seek ways to streamline the CDM process. Small-scale project methodologies have been a first step, but much more hope lies in programmatic CDM and, possibly, a future sectoral CDM. It also notes problems associated with baseline approach 22/48(a), which freezes the ex-ante baseline scenario for the project’s crediting period, and suggests that a “moving” baseline might be more appropriate for accounting for changes that affect leakage and additionality. Those interested in forest bio-carbon implementation should monitor methodologies being developed in the voluntary market, particularly under the Voluntary Carbon Standard (VCS), which is a source of innovation in the field. Trends in both CDM and VCS suggest that future bio-carbon methodologies will build in more systemic accounting methods to manage system-wide non-permanence, leakage and additionality risks.

Chapters 5 and 6 begin the move into bio-energy through discussion of domestic bio-energy (particularly cookstove usage) and charcoal production, both very much rooted in the use of fuelwood. **Chapter 5**, by Mulugeta Adamu, observes that biomass provides nearly 70-90% of the

primary energy in Africa. Of the biomass energy supply in Africa, some 90% is used in households with extremely wasteful traditional cookstoves that typically attain barely 5-15% efficiency. The low level of biomass fuel conversion efficiency is also a leading cause of indoor pollution and respiratory diseases. It also generates needlessly large quantities of GHGs. In view of addressing these adverse impacts, many developing countries have initiated programmes for improvement of domestic cooking fuels and conversion efficiency. Such programmes have, in many countries, resulted in impressive improvements of cookstove efficiency, up to 30-40% in some cases. Improved biomass fuels, such as biogas and—more recently—producer gas, have been deployed in appropriately designed stoves. Substantial improvement in fuel savings and reduction of indoor pollution at national, sub-regional and regional levels can be achieved by pursuing favourable policies, introducing financial and legal instruments, and formulating strategies for aggressive development and dissemination of improved biomass technologies.

Chapter 6, by Yisehak Seboka, focuses on the production of charcoal, which constitutes the primary urban fuel in Africa and is also a major source of income and environmental degradation in rural areas. With a lack of alternatives, demand for biomass in Africa is expected to double over the next ten years. Methods of charcoal production in Africa are in urgent need of upgrading. During the traditional process of carbonisation, only around 35% of the wood carbon is fixed in charcoal, while the remainder is released into the atmosphere as smoke and non-condensable gases. Because most of the energy of the fuelwood is lost in the production process, charcoal users ultimately use much more fuelwood than direct fuelwood users. The chapter reviews existing technologies for charcoal production as well as challenges and barriers to sustainable charcoal production. As key steps, it suggests legal recognition of charcoal production to draw producers out of the informal sector, as well as improved land tenure systems to control prices. Such reforms would help reveal charcoal's real economic value and facilitate the adoption of new charcoal technologies.

Chapter 7, by Jeffrey Biggs, steps back from specific bio-energy technologies in order to consider policy options to catalyze the overall bio-energy sector in Africa. This chapter shows that prospects exist for more efficient and sustainable bio-energy technologies, ranging from the direct combustion of forest and agricultural products to pyrolysis, gasification, anaerobic digestion, alcoholic fermentation and mechanical conversion of oil-seeds. Differing from other regions, concerns about energy delivery, industrial efficiency and sanitation will be the main drivers of bio-energy policy change in Africa. Yet any policy will need to be designed to overcome barriers that bio-energy development faces in Africa, particularly (though not limited to) opposition from vested interests associated with fossil fuels, up-front costs, supply chain complexity, competition for land and resources, inadequate demand, relatively rare suitable sites, low management capacity and a paucity of available investment and research funds. Policy options, including financial incentives (feed-in tariffs, green certificates, tender schemes, blending requirements and differential taxation), research and entrepreneurial development, power purchase liberalization and demonstration projects, will all help to overcome these barriers, funded either through self-financing, the CDM, international donors or microcredit.

Chapter 8, by Stephen Karekezi, Waeni Kithyoma and Oscar Onguru, discusses anaerobic digestion-based biogas energy generation. The purpose of this chapter is to identify the opportunities and barriers associated with the technology in order to suggest promising approaches and policies for its promotion. The chapter assesses the technical, financial, regulatory and awareness barriers facing biogas technology and also recommends policy and financial instruments (including carbon finance) that have been used to stimulate investment in the technology. The study is not confined to Africa but ranges beyond the continent to garner global lessons on how broader use of biogas can be catalysed in Africa. Examples are included of successful implementation of biogas energy as well as the enabling conditions needed for its implementation. While the challenges in Africa are sizeable, the success of biogas in other regions suggests it is worthwhile pursuing.

The next two chapters deal with biomass cogeneration, particularly with regard to bagasse. **Chapter 9**, by Stephen Karekezi, Waeni Kithyoma and Maryanne Kamoche, observes that, while biomass cogeneration has traditionally been practised by sugar factories in eastern and southern Africa, the technologies that are installed are inefficient and do not optimize the use of biomass as a fuel. The chapter reviews the opportunities available for biomass cogeneration, key drivers and the barriers preventing the significant potential of cogeneration from being fully realized. With the use of modern and efficient cogeneration systems, factories can generate enough heat for their process requirements and electricity to meet the factory requirements, as well as for export. It suggests policy, financial and technical measures that would assist in accelerating cogeneration development in Africa.

Chapter 10, by Prakash Deenapanray, is focused on the evolution of bagasse co-generation in Mauritius and discusses a number of policy instruments that have been used to support its development, including planning and regulatory paths, financial and tax incentives, power purchase agreements (PPAs), research and development, and equity participation. The use of bagasse in the generation of electricity has had a pronounced contribution in reducing the emissions of CO₂ in Mauritius. The paper also considers the possibility of replicating the experience of Mauritius in other African countries by specifically looking at the case of Mozambique. From this analysis, it is suggested that the CDM represents a powerful tool to promote bagasse cogeneration in the developing world.

Chapter 11, by Yared Haile-Meskel, moves the discussion to the industrial level with a review of the use of biomass in clinker production in the cement industry, which is one of the largest sources of GHGs. The paper reports experiences of different countries that are using biomass in cement production plants. The technology of preparation, feeding, and burning of biomass in cement kilns is widely available and could be used to implement the co-firing of biomass along with fossil fuels. Taking Ethiopia as an example, the paper makes recommendations for formulating a strategy for integrated biomass technology to achieve not only economic benefits but also to deliver long-term energy security and sustainable development. Published data confirms that this investment is economically justifiable and environmentally beneficial.

Chapter 12, by Simon Dalili, dispels even further the notion that bio-energy is not a technologically advanced fuel option through an overview of pyrolysis and gasification. Pyrolysis and gasification are thermo-chemical conversion technologies that decompose biomass and its residues into valuable intermediate products. One prime advantage of these technologies is that they can make use of almost any feedstock. Slow pyrolysis for charcoal production is a well-known technology, while fast pyrolysis also occurs in the absence of oxygen but at higher temperatures and a significantly shorter time. Gasification is the process of partial oxidation of a solid or liquid carbonaceous material by heating at temperatures above 800°C, in the presence of an oxidizing agent, during which the feedstock breaks down to produce raw gas. The raw gas can then be combusted immediately to produce heat and electricity or further transformed into liquid fuels. The bio-refinery concept—i.e. parallel production of several commodities such as electrical power, biofuels and chemicals from the same feedstock—is essential to the promotion of pyrolysis and gasification. The chapter closes with a discussion of suitable policy and financial instruments that can promote biomass pyrolysis and gasification.

In **Chapter 13**, Stephen Karekezi, Waeni Kithyoma and Oscar Onguru evaluate the opportunities and barriers associated with the use of urban waste as an energy source. Landfill bio-energy is promising because it can simultaneously reduce methane emissions and generate renewable energy in the form of biogas. Unlike industrialized countries, cities in developing countries generate waste rich in vegetative and decomposable materials, including human and animal waste. Three different options are identified for generating energy from such biological waste: anaerobic digestion, incineration and landfill gas (LFG) production. Each is considered in terms of advantages and disadvantages, economics of implementation (costs, revenues and opportunity costs) as well as

technical, financial, environmental, regulatory and awareness barriers. The chapter recommends policy and financial instruments (including carbon finance) that have been (or could be) used to stimulate investment in landfill bio-energy. It observes that a number of successful LFG projects have been realized under the CDM, including in Africa.

2.7. COMMON GROUND AND KEY MESSAGES

Carbon finance will not solve all of Africa's land-use and energy problems, but it can provide an additional revenue stream to improve sustainability in the sector as well as the profitability of emerging technologies. The potential to harness carbon finance to promote sustainable forestry, agro-forestry and bio-energy will depend on understanding of the CDM and other carbon systems on the part of project developers, but also on the performance of the CDM itself. Recalling the McKinsey (2009) global GHG abatement cost curve (Figure 2-1), such global opportunities are only of value to private investors when there is a functioning market mechanism to monitor trades and enforce market rules. The complex rules of the CDM are a testament to the difficulties associated with the creation of an artificial market. Yet, despite the obvious imperfections of the CDM and carbon finance more generally, it is a functioning – and, indeed, fast-growing and vibrant – market. There are opportunities here, but expectations need to be tempered by the realities of an emerging market for bio-carbon specifically.

A number of common themes emerge across the chapters assembled here. Distinguishing between carbon finance issues, broader policy issues and specific bio-carbon issues represents a useful basis for analysis. By carbon finance issues, we refer to the complexities of transforming a typical reforestation or bio-energy project into one that can tap into the extra revenue streams offered through the carbon market. As should be evident from the earlier review of the CDM project cycle and concerns about non-permanence, leakage and additionality, the degree of technical expertise and regulatory review required of CDM projects is high. Bio-carbon project developers should monitor policy developments with regard to these issues. A reformed CDM (or REDD) might move away from its project-based origins in order to address these challenges in a systemic manner through sectoral or policy-based approaches.

At the same time, many of the bio-carbon technologies discussed in this book are, in many instances, already financially viable—even in the absence of carbon finance. Particularly when linked to energy efficiency and industrial projects, bio-energy has the potential to pay for itself. This suggests that there are important policy issues, such as lack of financing, stable prices and clear land tenure arrangements, that are acting to prevent bio-carbon projects from getting off the ground. The authors here have identified a number of different barriers to bio-carbon projects in Eastern and Southern Africa but also a range of policy options that could be put in place to overcome such barriers. These include feed-in tariffs, green certificates, tender schemes, blending requirements, power purchase agreements, differential taxation—not to mention political goodwill and awareness. But, particularly because so many bio-carbon projects involve land, attention needs also to be given to tenure reform, community-based natural resource management and corporate-community partnerships. Involving local communities is not only socially just, but can bring down the costs of management and monitoring. Fortunately, financial barriers are not the only ones recognized by the CDM in determining project additionality. Other barriers that, once overcome, can justify the generation of carbon credits include institutional and technological barriers as well as barriers related to local tradition, prevailing practice, local ecological conditions, social conditions and land ownership conditions. Carbon finance can, in certain circumstances at least, be a powerful incentive to remove barriers to sustainable forest and bio-energy policies.

Lastly, there are specific issues related to bio-carbon, which separate the bio-carbon sector from other carbon finance sectors. Reforestation projects have high upfront costs and do not deliver benefits until years later when the trees are mature. Commercially viable bio-energy technologies typically require feedstocks that are constant in terms of quality, moisture content and supply. Bio-carbon sinks and bio-energy feedstocks are at risk of future climate change. There are difficulties in measuring bio-carbon, which is often assessed at the landscape level. Even household and organic waste in Africa is often scattered over large areas in a way that is not conducive to centralized collection and processing for producing LFG. These additional costs have certainly slowed adoption of bio-carbon projects in the CDM, particularly in comparison with large industrial projects. As new technologies emerge, such as remote sensing and the “bio-refinery” concept, the opportunity remains for sizeable emission reductions and sequestration to be achieved through bio-carbon.

2.8. REFERENCES

- Agrawal, A., and Gibson, C.C. (1999) Enchantment and disenchantment: the role of community in natural resource conservation. *World Development* 27: 629-649.
- Archer, D. (2005) Fate of fossil fuel CO₂ in geologic time. *Journal of Geophysical Research* 110: C09S05.
- Bernoux, M., Eschenbrenner, V., Cerri, C.C., Melillo, J.M., and Feller, C. (2002) LULUCF-based CDM: too much ado for...a small carbon market. *Climate Policy* 2: 379-385.
- Black, L. (2009) *The Financial Aspects of CDM Projects: Selected Observations*: Presentation at the Regional Bio-carbon Workshop, 21-24 April 2009, Addis Ababa, Ethiopia.
- Boyd, E., Corbera, E., and Estrada, M. (2008) UNFCCC negotiations (pre-Kyoto to COP-9): what the process says about the politics of CDM sinks. *International Environmental Agreements* 8: 95-112.
- Brockington, D. (2007) Forests, community conservation, and local government performance: the village forest reserves of Tanzania. *Society & Natural Resources* 20: 835-848.
- Capoor, K., and Ambrosi, P. (2009) *State and Trends of the Carbon Market 2009*. Washington DC: International Emissions Trading Association (IETA) and World Bank Carbon Finance.
- CDM EB (2008) *Report of CDM Executive Board, 44th Meeting, Annex 3 "Clean Development Mechanism Validation and Verification Manual"*. Bonn: UNFCCC.
- CDM Meth Panel (2008) *33rd Meeting Report, Annex 11 "Proposal for an enhanced barrier test for project activities that have a potentially high profitability without CER revenues"*. Bonn: UNFCCC.
- CLEP (Commission on Legal Empowerment of the Poor) (2008). *Making the Law Work for Everyone, Volume II Working Group Reports*. New York: UNDP.
- Cooke, B., and Kothari, U. (2001) *Participation: The New Tyranny?* London: Zed Books.
- Cosbey, A., Parry, J.-O., Browne, J., Babu, Y.D., Bhandari, P., Drexhage, J., and Murphy, D. (2005) *Realizing the Development Dividend: Making the CDM Work for Developing Countries*. Winnipeg: IISD.
- de Gouvello, C., Dayo, F.B., and Thioye, M. (2008) *Low-carbon Energy Projects for Development in Sub-Saharan Africa: Unveiling the Potential, Addressing the Barriers*. Washington DC: World Bank.
- Doelle, M. (2005) *From Hot Air to Action? Climate Change, Compliance and the Future of International Environmental Law*. Toronto: Thomson Carswell.
- Dutschke, M., Butzengeiger, S., and Michaelowa, A. (2006) A spatial approach to baseline and leakage in CDM forest carbon sinks projects. *Climate Policy* 5: 517-530.
- EU Directive (2009/29/EC) *Directive 2009/29/EC of the European Parliament and of the Council of 23 April 2009 amending Directive 2003/87/EC so as to improve and extend the greenhouse gas emission allowance trading scheme of the Community*. Brussels: EU.
- Eyzaguirre, J., and Kalas, N. (2002) Chapter 1: Science and Policy. In *Establishing National Authorities for the CDM*. Figueres, C. (ed). Winnipeg and Washington, DC: International Institute for Sustainable Development and the Center for Sustainable Development in the Americas.
- Fearnside, P.M. (2001) Saving tropical forests as a global warming countermeasure: an issue that divides the environmental movement. *Ecological Economics* 39: 167-184.
- Forner, C., Blaser, J., Jotzo, F., and Robledo, C. (2006) Keeping the forest for the climate's sake: avoiding deforestation in developing countries under the UNFCCC. *Climate Policy*, 6: 1-20.

- Forsyth, T., and Young, Z. (2007) *Climate Change CO₂lonialism*. Website (accessed 10 May 2007): <http://www.metamute.org/en/Climate-Change-CO2lonialism>.
- Friedlingstein, P., Cox, P., Betts, R., Bopp, L., von Bloh, W., Brovkin, V., Cadule, P., Doney, S., Eby, M., Fung, I., Bala, G., John, J., Jones, C., Joos, F., Kato, T., Kawamiya, M., Knorr, W., Lindsay, K., Matthews, H.D., Raddatz, T., Rayner, P., Reick, C., Roeckner, E., Schnitzler, K.-G., Schnur, R., Strassmann, K., Weaver, A.J., Yoshikawa, C., and Zeng, N. (2006) Climate-carbon cycle feedback analysis: results of the C4MIP model intercomparison. *Journal of Climate* 19: 3337-3353.
- Galik, G.S., and Jackson, R.B. (2009) Risks to forest carbon offset projects in a changing climate. *Forest Ecology and Management* 257: 2209-2216.
- Gibson, C.C., McKean, M.A., and Ostrom, E., (eds) (2000) *People and Forests: Communities, Institutions, and Governance*. Cambridge, MA: MIT Press.
- Gilbert, J. (2007). Indigenous Rights in the Making: the United Nations Declaration on the Rights of Indigenous Peoples. *International Journal on Minority and Group Rights*, 14, 207-230.
- Gold Standard (2008) Methodology for Improved Cook-stoves and Kitchen Regimes V.01. Geneva: The Gold Standard.
- Governments of Papua New Guinea and Costa Rica (2005) *Reducing Emissions from Deforestation in Developing Countries: Approaches to Stimulate Action* (UN Doc. FCCC/CP/2005/MISC.1.). Bonn: UNFCCC.
- Gundimeda, H. (2004) How “sustainable” is the “sustainable development objective” of CDM in developing countries like India? *Forest Policy and Economics* 6: 329-343.
- Gupta, J. (2000) *"On Behalf of My Delegation,...": A Survival Guide for Developing Country Climate Negotiators*. Amsterdam: Climate Change Knowledge Network.
- Hamilton, K., Bayon, R., Turner, G., and Higgins, D. (2007) *State of the Voluntary Carbon Markets 2007*. London & Washington DC: New Carbon Finance & The Ecosystem Marketplace.
- Hamilton, K., Sjardin, M., Shapiro, A., and Marcello, T. (2009) *State of the Voluntary Carbon Markets 2009*. London & Washington DC: New Carbon Finance & The Ecosystem Marketplace.
- IISD (2009) Summary of the Bonn Climate Change Talks: 1-12 June 2009. *Earth Negotiations Bulletin*, 12.
- IPCC (1996) *Revised 1996 Guidelines for National Greenhouse Gas Inventories*. Kanagawa, Japan: IPCC-NGGIP.
- IPCC (2003) *Good Practice Guidelines for Land Use, Land-Use Change and Forestry*. Kanagawa, Japan: IPCC-NGGIP.
- IPCC (2006) *2006 IPCC Guidelines for National Greenhouse Gas Inventories*. Kanagawa, Japan: IPCC-NGGIP.
- IPCC (2007a) Summary for Policymakers. In *Climate Change 2007: Impacts, Adaptation and Vulnerability. Contribution of Working Group II to the Fourth Assessment Report of the Intergovernmental Panel on Climate Change*. Parry, M.L., Canziani, O.F., Palutikof, J.P., van de Linden, P.J. and Hanson, C.E. (eds). Cambridge: Cambridge University Press.
- IPCC (2007b) *Fourth Assessment Report, Climate Change 2007: Synthesis Report (Longer Report)*. Cambridge: Cambridge University Press.
- Jung, M. (2003) The Role of Forestry Sinks in the CDM - analyzing the effects of policy decisions on the carbon market. *HWWA Discussion Paper* 241.
- Jung, M. (2005) The Role of Forestry Projects in the Clean Development Mechanism. *Environmental Science & Policy* 8: 87-104.
- K:TGAL (2009) *Suggestions for submissions in response to Draft SBSTA 29 agenda item 5: reducing emissions from deforestation in developing countries: approaches to stimulate action*. Enschede, The Netherlands: K:TGAL. Website (accessed 12 June 2009): <http://www.communitycarbonforestry.org/NewPublications/Suggestions%20for%20response%20to%20REDD%20Draft%20SBSTA%2029%20agenda%20item%205%20paras%2010%20and%2011.pdf>.
- Kant, S. (1999) Endogenous rate of time preference, traditional communities, and sustainable forest management. *Journal of Social and Economic Development* 2: 65-87.
- Kant, S., and Barry, R. (2001) A theoretical model of optimal forest regimes in developing economies. *Journal of Institutional and Theoretical Economics* 157: 331-355.
- Keller, K., McInerney, D., and Bradford, D.F. (2008) Carbon dioxide sequestration: how much and when? *Climatic Change* 88: 267-291.
- Lang, C., and Byakola, T. (2006) *"A funny place to store carbon": UWA-FACE Foundation's Tree Planting Project in Mount Elgon National Park, Uganda*. Montevideo & Moreton in Marsh: World Rainforest Movement.

- Lenton, T.M., Held, H., Kriegler, E., Hall, J.W., Lucht, W., Rahmstorf, S., and Schellnhuber, H.J. (2008) Tipping elements in the Earth's climate system. *Proceedings of the National Academy of Sciences* 105: 1786-1793.
- Lohmann, L., (ed) (2006) *Carbon Trading - A Critical Conversation on Climate Change, Privatisation and Power*. Dorset: Dag Hammarskjold Foundation, Durban Group for Climate Justice and The Corner House.
- Malhi, Y. (2002) Carbon in the atmosphere and terrestrial biosphere in the 21st century. *Philosophical Transactions of the Royal Society of London Series A* 360: 2925-2945.
- Malhi, Y., and Phillips, O.L. (2004) Tropical forests and global atmospheric change: a synthesis. *Philosophical Transactions of the Royal Society of London Series B-Biological Sciences* 359: 549-555.
- Malhi, Y., and Wright, J. (2004) Spatial patterns and recent trends in the climate of tropical rainforest regions. *Philosophical Transactions of the Royal Society of London Series B-Biological Sciences* 359: 311-329.
- Maréchal, K., and Hecq, W. (2006) Temporary credits: a solution to the potential non-permanence of carbon sequestration in forests? *Ecological Economics* 58: 699-716.
- McKinsey & Co. (2009) *Pathways to a Low-Carbon Economy: Version 2 of the Global Greenhouse Gas Abatement Cost Curve*. New York: McKinsey & Company.
- Michaelowa, A., and Jotzo, F. (2005) Transaction costs, institutional rigidities and the size of the clean development mechanism. *Energy Policy* 33: 511-523.
- Minang, P.A., McCall, M.K., and Bressers, H.T.A. (2007) Community capacity for implementing Clean Development Mechanism projects within community forests in Cameroon. *Environmental Management* 39: 615-630.
- Moura-Costa, P., and Wilson, C. (2000) An equivalence factor between CO₂ avoided emissions and sequestration—descriptions and applications in forestry. *Mitigation and Adaptation Strategies for Global Change* 5: 51-60
- Murdiyarso, D., and Skutsch, M. (2006) *Community Forest Management as a Carbon Mitigation Option: Case Studies*. Bogor, Indonesia: Center for International Forestry Research (CIFOR).
- Niles, J.O. (2002) *Tropical Forests and Climate Change*. In *Climate Change Policy: A Survey*. Schneider, S.H., Rosencranz, A. and Niles, J.O. (eds). Washington, DC: Island Press, pp. 337-371.
- Oba, G., Sjaastad, E. and Roba, H. G. (2008). Framework for participatory assessments and implementation of global environmental conventions at the community level. *Land Degradation & Development*, 19, 65-76.
- Olsen, K.H. (2007) The Clean Development Mechanism's contribution to sustainable development: a review of the literature. *Climatic Change* 84: 59–73.
- Olsen, K.H., and Fenhann, J. (2008) *A Reformed CDM: Including New Mechanisms for Sustainable Development*. Roskilde: UNEP Risoe Centre.
- Orlando, B., Baldock, D., Canger, S., Mackensen, J., Maginnis, S., Socorro, M., Rietbergen, S., Robledo, C., and Schneider, N. (2002) *Carbon, Forests and People: Towards the Integrated Management of Carbon Sequestration, the Environment and Sustainable Livelihoods*. Gland, Switzerland and Cambridge: IUCN.
- Parker, C., Mitchell, A., Trivedi, M., and Mardas, N. (2009) *The Little REDD+ Book: An Updated Guide to Governmental and Non-Governmental Proposals for Reducing Emissions from Deforestation and Degradation*. Oxford: Global Canopy Programme.
- Phillips, O.L., Malhi, Y., Higuchi, N., Laurance, W.F., Nunez, P.V., Vasquez, R.M., Laurance, S.G., Ferreira, L.V., Stern, M., Brown, S., and Grace, J. (1998) Changes in the carbon balance of tropical forests: evidence from long-term plots. *Science* 282: 439-442.
- Pin, K.F. (2005) *The CDM Project Cycle, Transaction Costs and the Role of Institutions*. Selangor Darul Ehsan, Malaysia: Pusat Tenaga Malaysia. Website (accessed 20 June 2009): http://cdm.eib.org.my/useful_materials/Presentation/2.%20Transaction%20Costs%20%20CDM%20%20Fui%20Pin.pdf.
- Porter, J.R., and Semenov, M.A. (2005) Crop response to climatic variability. *Philosophical Transactions of the Royal Society of London Series B* 360: 2021-2035.
- Purdon, M. (2003) The Nature of Ecosystem Management: postmodernism and plurality in the sustainable management of the boreal forest. *Environmental Science and Policy* 6: 377-388
- Purdon, M. (2008) Community Forestry and the Carbon Market. In *Green Breakthroughs: Solving Environmental Problems Through Innovative Policies and Laws*. Caldecott, J. (ed). Nairobi: United Nations Environment Programme.
- Ribot, J.C., Agrawal, A., and Larson, A.M. (2006) Recentralizing while decentralizing: how national governments reappropriate forest resources. *World Development* 34: 1864-1886.

- SBSTA (Subsidiary Body for Scientific and Technological Advice) (2008) *Report of SBSTA on its 28th Session*. Bonn: UNFCCC.
- SBSTA (2009) Draft text for a decision on methodological guidance for activities relating to reducing emissions from deforestation and forest degradation in developing countries. Annex to *Reducing Emissions from Deforestation in Developing Countries: Approaches to Stimulate Action*. Bonn: UNFCCC.
- Schlamadinger, B., Bosquet, B., Streck, C., Noble, I., Dutschke, M., and Bird, N. (2005) Can the EU emission trading scheme support CDM forestry? *Climate Policy* 5: 199-208.
- Schlamadinger, B., Bird, N., Johns, T., Brown, S., Canadell, J., Ciccarese, L., Dutschke, M., Fiedler, J., Fischlin, A., Fearnside, P., Forner, C., Freibauer, A., Frumhoff, P., Hoehne, N., Kirschbaum, M.U.F., Labat, A., Marland, G., Michaelowa, A., Montanarella, L., Moutinho, P., Murdiyarso, D., Pena, N., Pingoud, K., Rakonczay, Z., Rametsteiner, E., Rock, J., Sanz, M.J., Schneider, U.A., Shuidenko, A., Skutsch, M., Smith, P., Somogyi, Z., Trines, E., Ward, M., and Yamagata, Y. (2007) A synopsis of land use, land-use change and forestry (LULUCF) under the Kyoto Protocol and Marrakech Accords. *Environmental Science & Policy* 10: 271-282.
- Schneider, L. (2007) *Is the CDM Fulfilling its Environmental and Sustainable Development Objectives? An Evaluation of the CDM and Options for Improvement*. Berlin: Institute for Applied Ecology.
- Stern, N. (2007) *The Economics of Climate Change: the Stern Review*. Cambridge: Cambridge University Press.
- Subak, S. (2003) Replacing carbon lost from forests: an assessment of insurance, reserves, and expiring credits. *Climate Policy* 3: 107-122.
- Terrestrial Carbon Group (2008) *How to Include Terrestrial Carbon in Developing Nations in the Overall Climate Change Solution*. New York: Terrestrial Carbon Group.
- The Economist (2009) Carbon capture and storage: trouble in store. *The Economist Magazine*, 5 March 2009.
- UNEP Risoe Centre (2009a) *CDM Projects by Host Region*. Roskilde, Denmark: UNEP-Risoe Centre. Website (accessed 2 July 2009): <http://www.cdmpipeline.org/cdm-projects-region.htm#6>.
- UNEP Risoe Centre (2009b) *CDM Projects by Type*. Roskilde, Denmark: UNEP-Risoe Centre. Website (accessed 2 July 2009): <http://www.cdmpipeline.org/cdm-projects-type.htm#6>.
- UNFCCC (2007a) *Decision 1/CP.13 Bali Action Plan*. Bonn: UNFCCC.
- UNFCCC (2007b) *Decision 2/CP.13: Reducing Emissions from Deforestation in Developing Countries: Approaches to Stimulate Action*. Bonn: UNFCCC.
- UNFCCC (2007c). Decision 9/CMP.3 Implications of possible changes to the limit for small-scale afforestation and reforestation clean development mechanism project activities. Bonn: UNFCCC.
- UNFCCC (2006) *Decision 1/CMP.2: Further Guidance Relating to the Clean Development Mechanism*. Bonn: UNFCCC.
- UNFCCC. (2005a). Decision 5/CMP.1 Annex: Modalities and procedures for afforestation and reforestation project activities under the clean development mechanism. Bonn: UNFCCC.
- UNFCCC. (2005b). Decision 7/CMP.1 Further guidance relating to the Clean Development Mechanism. Bonn: UNFCCC.
- UNFCCC (2005c) *Decision 11/CP.7 Definitions, Modalities, Rules and Guidelines Relating to Land Use, Land-Use Change and Forestry Activities under the Kyoto Protocol*. Bonn: UNFCCC.
- UNFCCC (2005d) *Decision 3/CMP.1, Annex: Modalities and Procedures for a Clean Development Mechanism*. Bonn: UNFCCC.
- UNFCCC. (2002). Decision 21/CP.8 Annex II, Appendix B "Indicative simplified baseline and monitoring methodologies for selected small-scale CDM project activity categories". Bonn: UNFCCC.
- UNFCCC. (2001). Decision 17/CP.7: Modalities and procedures for a Clean Development Mechanism as defined in Article 12 of the Kyoto Protocol. Bonn: UNFCCC.
- UNFCCC Secretariat (2008) *Compilation and Analysis of Available Information on Ways and Means to Enhance Equitable Regional and Subregional Distribution of Projects under the Clean Development Mechanism*. Bonn: UNFCCC.
- VCS (2008) *Guidance for Agriculture, Forestry and Other Land Use Projects*. New York: Russell Mittermeier / Conservation International.
- Verstraete, M.M., Brink, A.B., Scholes, R.J., Beniston, M., Smith, M.S. (2008) Climate change and desertification: where do we stand, where should we go? *Global and Planetary Change* 64: 105-110.
- Victor, D. (2001) *The Collapse of the Kyoto Protocol and the Struggle to Slow Global Warming*. Princeton: Princeton University Press.
- Wara, M. (2008) Measuring the Clean Development Mechanism's Performance and Potential. *UCLA Law Review* 55: 1759-1803.

- Wara, M., and Victor, D. (2008) *A Realistic Policy on International Carbon Offsets*, PSED Working Paper #74. Stanford: Program on Energy and Sustainable Development, Stanford University.
- Weitzman, M.L. (2008) *On Modeling and Interpreting the Economics of Catastrophic Climate Change (REStat Version 6/5/08)*. Cambridge, MA: Department of Economics, Harvard University.
- Weitzman, M.L. (1974) Prices vs. Quantities. *The Review of Economic Studies* 41: 477-491.
- Wemaëre, M. (2009) *Update on EU Deliberations on Linking Forest-Based Mitigation to the EU ETS*. In WORKSHOP REDD+ & GHG markets Paris. Website (accessed 24 July 2009): <http://www.iddri.org/Activites/Ateliers/Matthieu-Wemaere.pdf>.
- Werksman, J. (1998) The Clean Development Mechanism: unwrapping the 'Kyoto Surprise'. *Review of European Community and International Environmental Law* 7: 147-158.
- Wily, L. (1999) Moving forward in African community forestry: trading power, not use rights. *Society & Natural Resources* 12: 49-61.
- Wirth, D.A. (2002) The Sixth Session (Part Two) and Seventh Session of the Conference of the Parties to the Framework Convention on Climate Change. *American Journal of International Law* 96: 648-660.
- WCED (World Commission on Environment and Development) (1987) *Our Common Future*. Oxford: Oxford University Press.
- World Bank (2004) *Sustaining Forests: A Development Strategy*. Washington, DC: The World Bank.
- World Rainforest Movement (2002) *Evaluation Report of V&M Florestal Ltda. and Plantar S.A. Reflorestamentos, both certified by FSC - Forest Stewardship Council*. Montevideo, Uruguay: World Rainforest Movement. Website (accessed August 12, 2005): <http://www.wrm.org.uy/countries/Brazil/fsc.html>.

3. CATALYSING FORESTRY IN AFRICA: A REVIEW OF FOREST POLICY OPTIONS AND INSTRUMENTS

By Jeffrey Biggs

Faculty of Forestry, University of Toronto

Contact: biggsjef@gmail.com

3.3. ABSTRACT

Given the abundance of land suitable for afforestation/reforestation (AR) in sub-Saharan Africa, the failure to attract carbon finance in general—but specifically CDM finance for AR—must be found in the region’s socio-economic, political and regulatory environment. This paper explores this enabling environment with a discussion of conditions for a successful forestry business model and the regulatory framework for sustainable forest management (SFM). The forestry business model is shaped by competition in supply, competition in land-use and competition between property rights regimes. The emerging regulatory framework for SFM promotes market-like instruments, decentralization towards community management and greater participation in governance. Within this enabling environment a number of policies are identified—each with its strengths and weaknesses—including tenure reform, legislative reform, forest certification, payment of ecosystem services (PES), community-corporate partnerships, agroforestry and non-timber forest product based (NTFP-based) rural development—any among which might be linked to carbon finance. However, any SFM policy and associated funding source becomes significantly more complex when considered in the CDM context.

3.4. INTRODUCTION – CARBON FINANCE AND FOREST MANAGEMENT IN AFRICA

In spite of significant potential for afforestation and reforestation (AR) activities to deliver profitable, sustainable outcomes for the rural poor throughout Sub-Saharan Africa (SSA), progress towards these objectives using the Clean Development Mechanism (CDM) of the Kyoto Protocol has been slow. In spite of numerous predictions (e.g. Jung 2005) of significant benefits for SSA, test projects have failed to deliver on their equity and local development objectives, and of the 5,000 projects in the CDM pipeline as of June 2009, only 49 were AR, and only 16 of these were in Africa – none of which had reached the registration stage (Boyd *et al.* 2007).

In the over-the-counter (OTC) market, the context of carbon finance for development in Africa seems even less promising. The total volume of carbon offsets *declined* from 2006 to 2007, at the same time as the average offset price was uncompetitive, more than twice as high as the global average (US\$13.70/tCO₂e, compared with a global average of US\$6.10/tCO₂e). As one consultant reported, “It just takes a long time to develop projects in this area of the world,” (Hamilton *et al.* 2008).

Even outside of questions of climate change mitigation, the practice of forestry in Africa has been troubled of late. In its 2005 Global Forest Resources Assessment, the Food and Agriculture Organization (FAO) gave Africa the poorest score on its sustainable forest management (SFM) report card (FAO 2005). Out of 16 reported elements, negative progress was reported for 5 (forest area, wooded land area, primary forest area, total forest area excluding plantations and area of forest designated primarily for production) with no change for 8. Only 3 areas showed improvement (total wood removals, total employment in forestry operations and area of productive plantations) – growth in the first two of which are, at best, ambiguous with respect to SFM. The final conclusion of the report is that progress towards SFM “appears to have been limited during the last 15 years.”

Given the abundance of land suitable for AR in SSA the failure of broader action of carbon finance in general, but specifically CDM-targeted AR, must be found not in the physical environment but in the socio-economic, political and regulatory environment—hereafter referred to as the ‘enabling environment’. This focus on the enabling environment recommends itself particularly as a counter-balance to the desire of specialists to look for solutions to problems solely in the area of their expertise. Given the generally unsatisfactory achievements of myriad development efforts in Africa in recent decades, it would therefore be myopic to seek solutions for carbon finance in forestry problems only from within the technical aspects of carbon finance.

Fortunately, the enabling environment for development activity in general and for forestry specifically has been a popular subject for study in SSA in recent decades, spurred by concerns about rural poverty, low economic growth, desertification and decentralized resource management, among others. A broad array of policy tools have been suggested and experimented with that are designed to promote this enabling environment for forestry. After a brief review of the forestry business model, the remainder of this paper will consist of a review of these policies, providing pros and cons, and examples of each, as practiced in Africa.

3.5. THE FORESTRY BUSINESS MODEL – WHAT MAKES A SUCCESSFUL FORESTRY PROJECT?

A note of caution is necessary before continuing. When discussing seemingly so simple and technical a concept as the ‘forestry business model’ the researcher and/or development practitioner is faced with the reality that two very different types of forestry operation exist.³ The first is large-scale (either extensive or intensive) industrial forestry, involving relatively high capital and labour investment and large, multinational corporations. The second is small-scale (either extensive or intensive) and involves low levels of capital and labour, and is practiced as a micro-enterprise (i.e. at the household or firm-of-less-than-5-employees level) to contribute to sustainable livelihoods. In principle, SFM can be achieved by management at either scale.

While the forestry business model holds many of the same features at both scales, these features are of varying levels of importance, and sometimes act in direct conflict with each other. The requirements for successful forestry outcomes (the forestry business model) can usefully be summarized under three broad topics applicable to both scales: competition in supply, competition in land-use and competition between property rights regimes.

3.5.A. COMPETITION IN SUPPLY

There is a perceived conflict in forestry: on the one hand, tropical deforestation, large-scale fire, continued alarmingly high extinction rates for tropical rain forest species, fuel wood supply which fails to meet demand and public conflict between user groups (preservationists, indigenous communities, the forest industry, etc) have resulted in large fluctuations in market price, and a conservative conclusion that forest resources are being over-exploited. On the other hand, the very sector that should benefit from this perceived shortage in wood products has been experiencing low, and sometimes negative, profits for the past several years, resulting in significant industry reorganization among the largest product suppliers (Hull and Ashton 2008, Oliver and Mesznik 2005).

It is the radically different political context of micro enterprise and large-scale forest management that produces this seeming contradiction. At the small-scale, issues of rural-urban governance conflict, unstable tenure and poverty result in the “resource conflict” observations of global forestry (see the following two sections), while the struggles of the global forest products industry can be explained relatively simply: an oversupply of wood products (Oliver and Mesznik 2005).

FAO (2005a) reports a global growing stock of 434 billion m³ of wood in forests, with current annual consumption at 3 billion m³ (less than 1%), implying an average harvest turnover of at least 100 years. Since such a long forest rotation is typically not financially desirable, large-scale forestry operations are constrained to exploit only the most profitable parts of the world’s forests, which (after Oliver and Mesznik 2005) require the following three characteristics: below-average planting and harvesting costs; lower transportation costs because of better access to processing facilities and markets; and high-quality common woods. Poor performance in these areas can be compensated for by an abundance of high-quality rare woods. In order to fulfill these criteria, the forest industry has invested heavily in capital-intensive, technological solutions in planting, harvesting, regeneration and improved growth stock, which have resulted in ever higher levels of production at ever lower costs, exacerbating the over-supply problem (Hull and Ashton 2008). As a result, firms throughout the

³ Of course, there is a continuum between these two poles of forestry operations, but for the sake of this chapter, these extremes form a worthwhile basis for discussion.

world have been divesting themselves of their forest management roles to focus more on processing, distribution and marketing, the emerging sources of profit (Bliss and Kelly 2008).

There are, of course, means to improve performance in African forestry in these three areas. High-quality common woods can be produced through improved species and higher growth rates, both of which can be achieved through traditional hybridization techniques or potentially through genetic modification. While the relatively dry conditions of Northern, Eastern and Southern Africa result in generally low per-hectare production rates, these could be improved in Western and Central Africa (Jindal *et al.* 2008; FAO 2005a). Furthermore, adjustments to forest rotation (i.e. the period a forest stand is allowed to grow before harvest) can improve either timber revenues or other forest benefits depending on project goals (Kaipainen *et al.* 2004). Significantly increasing the scale of operations can also result in economies of scale in ownership, management, production and transportation, as seen in the forest industry in general in recent years (Bliss and Kelly 2008). The negative effect of occasional disturbance events (e.g. insect disturbance, fire, windthrow) can be minimized through intensive management and monitoring (FAO 2005a).

These efforts to improve industrial forestry competitiveness require, however, significant flows of capital (Jindal *et al.* 2008). The record for capital investment in Africa has never been particularly strong, however, and this has not improved in recent years (UNCTAD 1999; Dupasquier and Osakwe 2005). Even assuming abundant capital, however, its application towards the aforementioned technical applications requires significant management capacity and long-term social stability – weaknesses in the African investment context that have existed for some time (Jindal *et al.* 2008). Simultaneously, transportation costs are a significant component of the total costs of delivered forest products, and are highly dependent on fluctuations within global energy markets (Oliver and Mesznik 2005). Given continued volatility in these markets, significant cash reserves (or access to enough credit to fund operations through intermittently high energy cost periods) will be necessary to undertake profitable forestry projects.

In this world over-supply scenario with strong competition, and the enduring nature of the above constraints on improving performance in Africa, the opportunity for an emerging African forest industry to compete with long-term industry participants is poor. The best option would seem to be to focus on intra-African demand for common woods (taking advantage of relatively low transportation costs) and a small supply of rare woods to the European market.

3.5.B. COMPETITION IN LAND-USE

Forest management tends to generate relatively low profits at any scale as a result of the long time-frames over which even intensively-managed rotations grow. When accompanied by high up-front costs, the result is long pay-back periods and high opportunity costs.

Land-use is driven by two different, yet similar, behaviours: rent-seeking and livelihood promotion. In the former case, access to resources that have been accumulated through natural processes over long time scales are sought by investors seeking windfall profits for minimal investment, while in the second case attempts are made to convert the natural productivity of land into either cash or calories adequate to sustain (or improve) local livelihoods. In each case, the returns of forest management to these actions are much lower than other land uses (in particular, agriculture), depending on the fertility of soil, distance to market, quality of wood products and density of other resources (e.g. commercially viable geological deposits). This proposition is supported both by global patterns of tropical deforestation and temperate afforestation. That is, agricultural expansion for livelihood promotion remains the single most important proximate cause of tropical deforestation (Delacote 2007). Furthermore, expansion of forests over the last half-century in North America and Europe has not been driven by any re-ordering of tenure rules or property rights, but simply by the fact that Euro-American agriculture is much less profitable relative to other employments, than in the previous century: marginal farmland is therefore returning to forest (Agrawal *et al.* 2008).

This reveals a simple fact of forest management: the forestry business model can only be employed profitably where there it faces few (if any) legitimate competitors for land-use. Where competition makes land scarce (which many are expecting in Africa as a result of climate change, population growth and other factors, e.g. Agrawal *et al.* 2008) forestry tends not to perform well.

This requires one of two strategies if continued forest use is a management goal: 1) constraining the expansion of competing land-uses, or 2) increasing the value of standing forest. The former is problematic: the practice of subsistence agriculture and animal husbandry within impoverished communities is as difficult to constrain as that constraint is to justify, and complaints regarding the human rights violations inherent in alienating land-use rights from either the poor and/or traditional users are myriad in Africa. However, some examples of such policies do exist, and will be treated in a later section. The latter is more hopeful but results to date have been disappointing. The failure of carbon finance to improve the value of standing forest in Africa to date has already been described. Rising prices for certain cash-crops have made the net present value of afforestation projects (even with carbon payments) un-competitive against agricultural production (e.g. in Nepal: Aune *et al.* 2005). Efforts in the last decade to improve the returns from Non-Timber Forest Products (NTFPs) through micro-credit provision and market expansion have been disappointing: while NTFPs (such as nuts, meat, rubber, medicines, etc.) contribute critically to the livelihoods of the poor, they are typically much less lucrative than agriculture and animal husbandry (Shone and Caviglia-Harris 2006). If forest management is to be promoted in areas where poverty is a significant influence on rural land-use patterns (e.g. much of Africa), then means to increase the value of forests will have to be promoted that acknowledge this reality.

3.5.C. COMPETITION BETWEEN PROPERTY RIGHTS REGIMES

The final element of the forestry business model refers to tenure: specifically, competition between competing tenure regimes. Differences in tenure are fundamentally questions of governance: “What systems will be used to manage forest resources?” and (more importantly) “Who determines what systems will be put in place?” Tenure competition is applicable to both scales of forest management, in that large-scale timber management often accompanies conflict with communities who possess (or demand) rights to recreational, NTFP, spiritual, aesthetic, geological or other usage rights. Furthermore, it is at this level of the business model that large-scale and micro-enterprise forest management often conflict, with family- and community-oriented forest managers frustrated in their ability to manage for certain goods because of tenure claims by large-scale timber rights holders, whose operations are sometimes frustrated in turn by reciprocal protest.

Due to the nature of forest management, it requires medium- to long-term investments (i.e. 10-250 years) to capture sustainable benefits, so the first requirement of property rights is that they be associated with stable tenure. Other requirements include clarity, legal recognition, duration, comprehensiveness, restrictions and the absence of conflict (FAO 2006). At least as important as the existence and form of property rights is whether rights holders possess the political ability to utilize them – that is, that the rights do not exist solely *de jure* but also *de facto* (Sen 1999). Of particular interest in the African case is whether tenure rights are communal (i.e. customary authority vested in a chief who grants claims and regulates land right transfers), public (i.e. this authority rests in the state), private (i.e. authority is held by an individual or corporation as a result of purchase or inheritance), or some combination of the three. While communal tenure is said to hold sway over most of Africa, the state retains a strong presence, owning 98% of forested land on the continent compared with 94% in Asia, 90% in Europe, 76% in South America and 66% in North America (FAO 2005a).

In spite of assertions by various researchers and institutions, a strong, universal correlation between any of these tenure forms and either changes in forest cover or the sustainability of forest management has yet to be made (Agrawal *et al.* 2008). Two points that are clear, however, are that

1) tenure stability (duration) and comprehensiveness are positively associated with SFM; and 2) land rights have endogenous components: although a lack of rights may preclude investment in forest, certain types of investment contribute to the establishment of rights (Besley 1995). Put another way, the argument that individuals need secure rights before they can be persuaded to invest has some truth behind it; but it is also true that certain investments, often including forestry, also allows individuals to acquire these rights. This can be argued to be the case for both small-scale communal management, and large-scale industrial management.

An effort at promoting SFM of particular interest to African contexts, and heavily implicated in the competition between different property rights regimes, is the question of community forestry. At the same time that large-scale, vertically integrated forestry firms have been selling their timberlands in temperate countries because their management is unprofitable, throughout the world rural communities have been asked (and expected) to manage forests in new, profitable and sustainable ways, particularly in regions where forestry has the least opportunity to be profitable (Agrawal *et al.* 2008; Bliss and Kelly 2008).

This push for decentralized management has been driven by a combination of factors: concern in donor countries that publicly-owned forests are being mismanaged, donor aid being made available to fund decentralization programmes, domestic pressure for recognition of the needs of rural communities, and a desire by state governments to economize their forest governance budgets. Similar pressures (accompanied by demand for rare woods and needed government revenue) have resulted in a proliferation of private, corporate concessions in West and Central Africa and a new emphasis on market-based means to promote SFM, in particular forest certification. A graphical representation of these pressures on governance can be seen in

Figure 3-1.

Figure 3-1: Pressures on forest governance

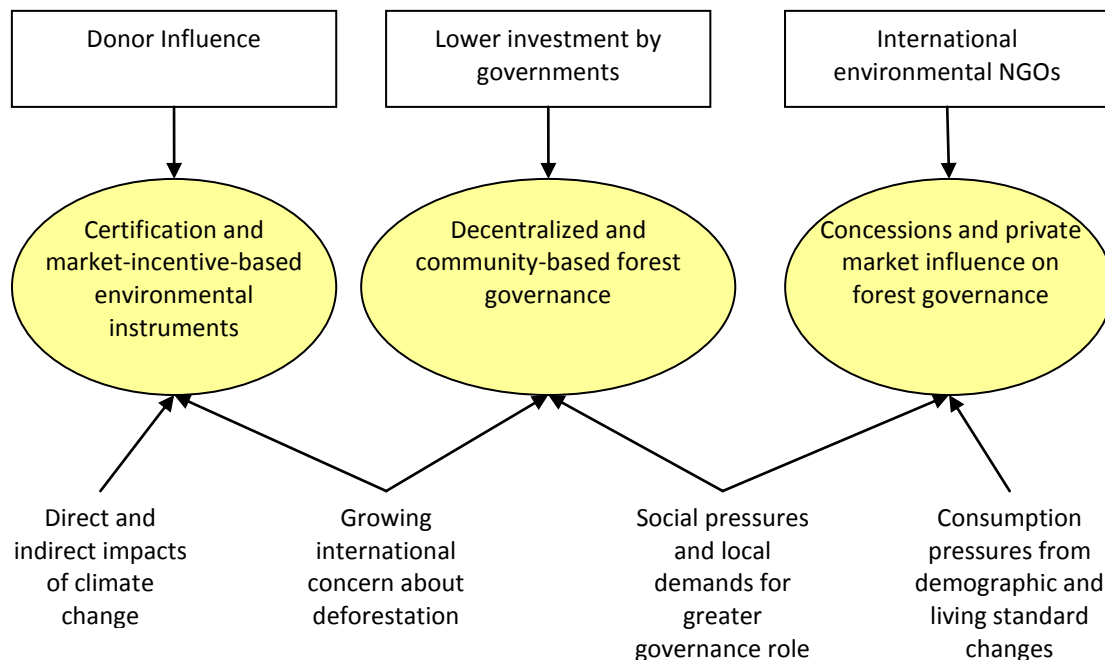

Source: Agrawal et al. (2008)

These pressures are not only resulting in important changes in property rights and governance, but they impact directly on the prospects for success of the same institutions they create. That is, small budgets and donor pressure to decentralize result in limited enforcement of privatization and

community agreements, resulting in large-scale illegal logging (Agrawal *et al.* 2008). The same forces, when combined with political privilege, also regularly allow powerful rural elites to capture the majority of benefits from the new opportunities provided by decentralization, particularly if the forests have a high value (Boyd *et al.* 2007; Iversen *et al.* 2006).

Policies to create an enabling environment for profitable forest management in Africa must therefore:

- Promote stable, comprehensive tenure systems
- Include systems of governance robust to political pressures
- Increase the value of standing forest relative to competing land-uses
- Focus on local demand for forest products and services or highly-prized, rare woods for export

The following section reviews policy options for achieving these goals.

3.6. WHAT POLICIES WILL CREATE AN ENABLING ENVIRONMENT FOR SUSTAINABLE FOREST MANAGEMENT IN AFRICA?

Before recommending policies to create enabling environments for successful forest projects, a point about the nature of trees must be made, one that is often lost in such discussion. The great strength of trees in their contribution to human welfare is that they are highly fungible – that is, forests and other lands with trees can be used to deliver a wide variety of goods and services at any given time. This, however, is also a great weakness in crafting effective policy: many stakeholders may agree with a policy that promotes afforestation, but all may have distinct goals for what goods and services that afforested land will deliver, resulting in conflict and frustration throughout the life of the project (Deweese 1995).

For instance, a single rural afforestation plan could simultaneously be promoted by a state government aiming to establish its presence in a region dominated by an opposition party, a local miller to ensure a steady flow of timber, an hereditary chief to establish land rights over a region contested with semi-nomadic herdsman, and the local mother's union as a source of accessible fuel. Each group may be enthusiastic about the project at the outset, but their clearly opposed interests cannot help but result in the "failure" of the project to achieve its "goal" from a donor perspective: sustainable forest management.

As a result, policies must be very carefully crafted which are cognizant not only of the forestry business model, but, at least as importantly, of the local political realities within which the project will operate. Policies recommended in this section must, therefore, be described in general terms, although their pros, cons and specific examples of such policies in action will be included.

3.6.A. TENURE REFORM

The promotion of stable and comprehensive tenure is critical to creating an enabling environment for SFM at both relevant scales. This does not necessarily imply auctioning off public land, transferring all state forests to community control and/or the elimination or promotion of communal tenure. Any of these reforms in one region could promote stable tenure, or unstable tenure, depending on political realities. In general, however, a policy of decentralized, community-based forest management has great potential for creating an enabling environment for profitable projects, providing the following principles (after Scherr *et al.* 2003) are fulfilled:

- Individual/household usage rights and boundaries are clearly defined.

- The distribution of benefits of the rules governing resource use is proportionate to the costs of those rules.
- Restriction on the timing, location, means and intensity of forest exploitation is locally determined.
- Most individuals affected by operational rules can participate in their modification.
- Monitors and auditors of compliance are accountable to the users.
- Graduated sanctions for rule violators from other users and officials accountable to users.
- Rapid, low-cost, local conflict resolution mechanisms.
- Right of users to create their own institutional solutions to management is not challenged by state authorities.

PROS AND CONS OF COMMUNITY-BASED FOREST MANAGEMENT

Community-based forest management designed according to the aforementioned principles has significant benefits. In Ghana, it has been shown that the more comprehensive property rights that small-holders are given, the more they will plant trees (for cocoa production) (Besley 1995). Similarly, even where communities have *de jure* rights over forests in Ghana, where these rights are not recognized by the Forestry Department (resulting in licensed loggers damaging food and crops to access high value timber) farmers have destroyed valuable trees species on their farms to keep concessionaires from accessing them (Owubah *et al.* 2001). It is important to note that in this example it was not a lack of exclusiveness in tenure that discouraged forest management: interviewed farmers indicated that private costs and private consumption of the benefits of the trees was unacceptable to them – the benefits were described as being community-oriented.

Similarly, Jindal *et al.* (2008) describe the Nhambita Community Carbon Project in Mozambique⁴ which has afforested more than 1,000 ha and delivered cash carbon payments to farmers even though the local chief retains formal title to all land. Traditional ownership structures can, and do, work. In Nepal, community-based forest management has been hailed as a highly successful method for achieving both ecological sustainability and poverty alleviation (Iversen *et al.* 2006).

On the other hand, the decentralization experience is not uniform. In Malawi, community-managed forests have lower biodiversity than public- or privately-owned lands and reforestation is more likely on privately-held lands than others, though it is unclear in this situation whether community tenure really is stable (Mwase *et al.* 2007). Further, in Fiji, community-based decentralization has resulted in increased conflict in forest management, though in this case community boundaries were not clearly demarcated nor were individual and community rights well defined (Murti and Boydell 2008). In Ghana, private land ownership has been demonstrated to promote the establishment of plantations and increase silvicultural investments (Zhang and Owiredu, 2007).

Most of the negatives associated with community-based forest management only appear relative to private ownership. While the debate over the preference of private or community ownership continues (Woodhouse 2003), it should be clear that even if private ownership is an ultimate policy goal, such a process should be commenced through decentralization to community ownership rather than directly from state control. Privatization directly from the state level is likely to increase inequality in land ownership through elite capture (specifically excluding women and the poor), a tendency which can indeed be exacerbated by measures to strengthen local control (Romano 2007; Woodhouse 2003).

⁴ <http://www.miombo.org.uk>

However, the experience with community management can be useful in identifying local political cleavages which promote inequality in the capture of forest benefits, as in the Nepalese case where, while the majority of low-value forests may result in equitable distributions of benefits, the few high-value forests tend to have inequitable benefit capture by elites (Iversen *et al.* 2006). Identifying and responding to these cleavages, as well as local experience with benefit distribution, monitoring and conflict resolution would hopefully result in more sustainable outcomes when (if) privatization eventually occurs.

Box 3-1: Village land forest reserves (Tanzania)

Village Land Forest Reserves can be established by a village council for the purpose of forest management in Tanzania – under which regime the council owns and manages the trees through a natural resource committee, group or individual. With reference to the eight principles stated above:

- Community rights and boundaries are defined by the council in the initial declaration.
- Costs and benefits are borne primarily by the committee, group or individual to whom management has been granted.
- Determining rules for establishment, planning and monitoring is the council's responsibility.
- The village council determines operational rules, so the local accountability of management is ultimately determined by the local accountability of the village council.
- Monitoring and auditing procedures are unclear.
- Sanctions for violation are at the discretion of the council, which has the right under the 2002 Forest Act to confiscate any products illegally harvested in the reserve, or equipment used in its harvest, and sell it with the proceeds used for the village.
- Conflict resolution mechanisms are unclear and vary from village to village.

State authority over the reserves is minimal: the state has also waived its royalties and transportation taxes on products from the reserves, as well as its restrictions on the use of commercially important and endangered tree species and has granted village council the power to enact bylaws to support their management plan.

Source: Romano (2007)

Early experience with this tenure reform indicates improved forest condition as a result of this decentralized, stable, comprehensive tenure reform (Romano 2007).

Tenure reform is not something to be entered into lightly: many examples of unsuccessful tenure reform exist. Programmes for land restitution and redistribution in South Africa have largely failed, at least in part because of conflict between traditional authorities and newly created administrations (Romano 2007). Similarly, active discouragement by politicians and a lack of formal application guidelines have prevented the reforms to Uganda's Land Act (1998) from resulting in the formation of any of the forest-owning Community Land Associations which it had envisioned. In both instances, a lack of accountability from state politicians and denying communities the right to establish their own leadership structures has resulted in failure (Romano 2007). At the same time, however, evidence from aboriginal commercial community forestry enterprises in Canada indicate strongly that the participation of elders or hereditary chiefs in decision making has a significant and negative effect on profitability (Trospen *et al.* 2008). While these principles can be used to establish SFM, it is clear that a strong grounding in the political nuances governing each region under consideration will have a powerful influence upon outcomes.

3.6.B. LEGISLATIVE REFORM

Given the dominance of the state in forest ownership in Africa, any discussion of policies to promote an enabling environment for SFM must begin with legislative reform. That is, a combination of sticks (regulations), carrots (financial incentives) and sermons (normative information transmission) enshrined in the laws and practices of the state apparatus to promote SFM at both small and large scales (Serbruyns and Luyssaert 2006). Simultaneously, given the foregoing discussion, this reform will tend to be done in a context of decentralization, as the movement away from central administration and top-down regulation continues (Agrawal *et al.* 2008).

While these legislative reforms must be generally discussed, broad guidelines can be identified to promote both sustainable and poverty alleviating results as has ably been done by Scherr *et al.* (2003): relinquish rights at the state level, reduce the regulatory burden and level the playing field for local producers in forest markets.

- **Relinquishing control at the state level** – in addition to the principles of tenure reform outlined earlier, in order for local groups to gain effective control of their resources, state institutions must be willing to relinquish control.
- **Reduce the regulatory burden** – for both large- and small-scale forestry, excessive regulation makes both compliance and access difficult, while providing no evidence that it improves ecological sustainability. Viable regulations can be maintained by focusing them on the most critical problems, sites and operators; simplifying existing regulations, encouraging voluntary regulation for community forests and promoting forest certification for large-scale operations.
- **Level the playing field for local producers in forest markets** – in many instances, large-scale producers and processors have privileged access to markets through subsidies and preferential granting of licenses. Timber floor prices, log sorting yards and facilitated marketing (in cases of profit-capturing oligopsonistic traders) can accompany decreasing subsidies and preferential licensing to improve performance.

PROS AND CONS OF LEGISLATIVE REFORM

Complex, burdensome regulations tend to serve little purpose other than the protection of entrenched political interests at the state level, contributing to inefficiency, corruption and intra- and international trade barriers, while simultaneously normalizing illegal forestry operations and keeping local producers from participating fully in the market (Larson and Ribot 2007). Centralized forestry ministries and their accompanying concession/license systems favour urban/elite access to forest goods and services for the sake of stable payments to state treasuries, rent-seeking and protecting long-established political interests (Larson and Ribot 2007). At the same time, however, reform of overly-burdensome regulations is costly, time-consuming and easily deflected by elite interests, leading to conflicting results.

Box 3-2: The Ghana Timber Resources Management Act (1997)

The Ghana Timber Resources Management Act (TRMA) has been hailed by various authors (e.g. Dubois 1999; Scherr *et al.*, 2003) for its collaborative nature, oriented toward the needs of rural communities. In particular, the TRMA established farmers' rights to decide when trees on their land are felled, the right to claim payment for felled trees from concessionaires and compensation for crop damage, and participation in the issuing of permits to forest companies.

Kufuor (2004), however, emphasizes the primary goal of the TRMA as eliminating small-scale chainsaw

operators who threatened the ability of timber millers to dictate prices to loggers. The mobile, small-scale chainsaw operators not only had significantly lower production costs than loggers and millers, but were outcompeting millers through direct competition in sales and by offering better prices to loggers.

The TRMA not only requires the payment of stumpage fees to the Forest Services Division, but it bans chainsaw operators from converting logs into lumber, and also requires them to compensate local communities, giving communities an incentive to monitor chainsaw activity. This has had the immediate effect of a) driving small-scale chainsaw logging underground, b) increasing deforestation (as on-the-spot chainsaw conversion is less efficient than milling), c) protecting the exploitative advantage of millers over large-scale licensed loggers and d) increasing the revenues of the Forest Services Division through a new stream of stumpage fees from large-scale loggers. A putative effort at decentralization has resulted in a greater consolidation of control over forest resources.

3.6.C. MARKET-LIKE PROMOTION OF SFM

As a result of a common perception of the generally poor performance of state-managed forestry world-wide, market-like means of promoting SFM have proliferated as a viable alternative in recent decades. At the risk of overgeneralization, two instruments have arisen to use direct financial incentives to support SFM, depending on the scale of forest management: forest certification for large-scale forest management, and payment for environmental services (PES) for small-scale forestry.

In the case of certification schemes, the forest manager invests capital in ensuring that operations comply with a predetermined set of criteria and indicators and is audited and certified by an external agency in order to gain access to (or increase share in) paper or timber markets whose consumers have a strong demand for SFM products. In the case of PES, the forest manager receives payments from a user-group directly benefiting from environmental services derived from a forest – benefits that would be lost or jeopardized by non-SFM activities.

Given the limited budgets available in most African treasuries for forest management, a desire to decentralize, and the global movement towards market-like management instruments, states can achieve many of their stated management goals through promoting forest certification and PES. For example, the government of Costa Rica has taken significant legislative steps in both areas, requiring forest certification and promoting PES widely (Pagiola 2008).

PROS AND CONS: FOREST CERTIFICATION

While many competing forest certification systems exist, guidelines developed jointly by the World Bank and the World Wildlife Fund (1998) have outlined the principles they deem necessary within any forest certification scheme:

- Compliance with all relevant laws
- Stable, documented tenure and use rights
- Recognition of legal and customary rights of indigenous peoples
- Efforts by forest management to enhance the long-term social and economic well-being of workers and communities
- Management for multiple benefits
- Management which conserves biological diversity and its associated values and structures.
- Written, comprehensive, long-term management plans
- Regular monitoring and assessment appropriate to the intensity of forest management
- Conservation and maintenance of natural forests
- Plantations designed and maintained such that they are compatible with the other principles

Furthermore, such certifications must be:

- Politically adapted to local conditions
- Goal-oriented in reaching objectives
- Acceptable to all involved parties
- Based on standards defined at the national level compatible with generally accepted principles of SFM
- Based on objective and measurable criteria
- Audited independently (and free of conflicts of interest)
- Credible to major stakeholder groups
- Cost-effective
- Transparent
- Provide equitable access to all countries

These principles, generally respected within the most common certification schemes (such as the Forest Stewardship Council and Programme for Endorsement of Forest Certification), hold near universal appeal: they are designed to encompass all foreseeable forest values.

This universality, unfortunately, can lead to difficulty maintaining all of the requirements simultaneously. For instance, certification schemes tend to be time-consuming and costly to define at the national level while maintaining their credibility with all stakeholder groups, leading to repeated accusations of a lack of transparency (a situation to which leading certifying systems, such as the Forest Stewardship Council, have acknowledged, e.g. Roberts 2007). Furthermore, the costs of auditing are typically borne by the management operation seeking certification, requiring significant up-front costs for uncertain benefits, while simultaneously providing strong incentives for auditors to “greenwash” the results (Roberts 2007). When combined with a lack of internal consumer demand in most of the tropics for sustainably managed forest products, this has led to low levels of certification in this region (Cashore *et al.* 2006). Furthermore, a number of controversial certifications have occurred despite the protests of several “major stakeholders” (Roberts 2007).

Box 3-3: Certification in Zambia

Zambia is a relatively large exporter of high-value sawn timber, primarily to South Africa, the USA and Botswana (92% of timber exports). Four FSC chain-of-custody certificates and two forest management certificates have been awarded in Zambia, though one of these was suspended in 2000. Motivation for the certification was to gain access to and improve share in international markets. There are currently no FSC criteria and indicator standards for Zambia, those of other countries being used. Certification was paid for out of the resources of the companies themselves, rather than through donor action.

While the FSC-certified area in Zambia is still very small (1,092 ha), it has prompted interest from the state-operated forest management company, ZAFFICO, in pursuing certification itself (Njovu, 2006). While still nascent, the experience with forest certification in Zambia is broadly reflective of other African experiences in forest certification, such as in Gabon and South Africa (Eba’a Atyi, 2006; Ham, 2006). Interest in forest certification has been driven by export-oriented domestic forestry firms whose pursuit and practice of certified SFM has prompted governments to respond by investigating certification themselves.

This is in contrast to the case of Estonia, where certification was actively promoted by the government, culminating in the FSC certification of all state-owned forests in 2002 (approximately 1 million ha), resulting in positive trickle-down effects on private Estonian forestry practices (Ahas *et al.*, 2006).

A more pro-active approach by African states with high levels of exports from state forests could lead to significant progress in SFM, while increasing potentially lucrative market access in Europe.

PROS AND CONS: PAYMENT FOR ENVIRONMENTAL SERVICES

PES programmes are, like SFM certification, a relatively novel means of promoting SFM and, like SFM, are diverse enough to make sweeping generalizations difficult. Nonetheless, general principles for successful PES programs have been developed (after Wunder *et al.* 2008):

- Forest service users must be clearly identifiable
- Rights holders must be clearly identifiable
- A steady flow of payments to promote/reinforce behaviour must be established
- The relationship between the promoted management regime and the service enjoyed by users must be clearly established and recognized by all stakeholders with appropriate sanctions for non-compliance
- The regulatory system governing payments must be transparent and well understood by participants

In keeping to these principles, a number of generally successful PES systems have been executed, which have in turn served as bases for other “daughter” programmes (e.g. the Pimampiro Watershed Protection Programme in Ecuador).

PES programmes do have a number of weaknesses, however: namely the risk of high transaction costs, leakage, additionality and both the level and willingness to levy sanctions against violators (Wunder and Alban 2008). Furthermore, PES programmes that are government-financed tend to be poorly targeted, only loosely tailored to local conditions and have poorer monitoring and willingness to enforce conditionality than user-financed programmes, which also suffer from fewer confounding side objectives (Wunder *et al.* 2008). Finally, volatile prices and demand shocks outside of the influence of such programmes can result in payments rather suddenly falling below the level necessary to maintain the desired management regime (Frost and Bond 2008; Ibarra Gene 2007).

Box 3-4: Zimbabwe’s CAMPFIRE programme

Over its first 12 years (1989-2001), Zimbabwe’s Communal Areas Management Programme for Indigenous Resources (CAMPFIRE) served as a model for the promotion of decentralized, sustainable resource management through direct payments to community managers.

Rural District Councils (RDCs) possess the right to grant access to wildlife for safari operators on behalf of communities living on communal land, who then sell photographic and hunting safaris to tourists. Communities are then paid a portion of the revenue according to a pre-agreed formula to encourage use of the communal lands that does not jeopardize wildlife habitat. In the period 1989-2001, CAMPFIRE transferred over US\$20 million to participating communities, providing a direct incentive to communities to manage range and forest land for the promotion of wildlife.

CAMPFIRE is far from an ideal PES system, notably because sanctions for non-compliance with proposed management plans are seldom enforced. Furthermore, CAMPFIRE received a large amount of donor aid in its start-up – which seems to be a near-universal requirement for successful PES establishment: the costs of institutional development, addressing property rights conflicts, developing supportive administrative processes, education and training, monitoring and enforcement before any revenues are delivered are daunting.

Recent deepening rural poverty in Zimbabwe, driven by higher-level macroeconomic and political processes, including steps towards the recentralization of wildlife management, has jeopardized the sustainability of the model by increasing pressure on rural communities to exploit natural resources (including wildlife) for subsistence purposes. Nonetheless, a commitment to CAMPFIRE processes remains strong in some communities – demonstrating the resilience of the model (Frost and Bond, 2008).

3.6.D. CORPORATE-COMMUNITY PARTNERSHIPS

In countries and regions with an active, export-oriented timber industry, or where demand for low-cost domestic timber is high, corporate-community partnerships have proven a mutually beneficial means of promoting sustainable SFM outcomes through outgrower schemes (particularly in encouraging the afforestation of marginal, small-scale, farmland).

These partnerships occur when a forest products firm defrays establishment costs for plantations on community/small-holder land, provides extension services and purchases the timber at a pre-arranged, guaranteed price. Such partnerships provide a host of mutual benefits: the timber/milling company is able to expand its long-term, locally sourced supply at guaranteed rates, while individual farmers and communities are able to benefit from the reduced risk associated with diversification of their activities, future revenue, and the amenity and production values associated with having growing trees on agricultural sites.

Given the range of benefits that tropical plantations can provide in regions long deforested, and the slow pace at which Africa is adopting plantations as viable sources of wood products (only 2% of Africa's forest area is plantations, compared with 11% in Asia for example), such efforts should be encouraged as long as standing, natural forest is not at risk of being converted to a plantation (Nawir *et al.* 2007). Analyses of Costa Rican afforestation programmes indicate that small-farm size, high labour-intensive agriculture activities, abundant labour, and dependency on farm income all reduce the incentives to participate (Thatcher *et al.* 1997). Given that these disincentives tend to be in place in many African farming communities, the challenge facing afforestation is clear.

Corporate-community partnerships can redress some of these problems through adhering to the following principles (after Scherr *et al.* 2003):

- Mutual respect of both partners' aims
- Fair negotiation process, facilitating free and informed decisions
- Realistic prospects of mutual profits commensurate to contributions
- Long-term commitment
- Explicitly described, equitably shared risks
- Availability of accurate, in-depth and independent information on all sources of costs, benefits and constraints to success
- Sound business principles

Governments can play a facilitating role in these partnerships through providing information to potential participants and, *if* such an arrangement is being pursued, assisting in the transportation and provision of physical inputs. Further, the elimination of registration fees, transportation taxes and subsidies for large-scale producers will tend to encourage outgrower activities (Scherr *et al.* 2003).

PROS AND CONS OF OUTGROWER SCHEMES

Outgrower schemes provide a very low-cost way for governments to promote afforestation, and are more likely to be successful than simple plans to provide free seedlings in that they increase the revenue stream from standing timber by guaranteeing future sales at a given price. They are also compatible with the aforementioned pressures toward decentralization and the promotion of corporately-oriented, market-based development.

They are unlikely to be successful, however, if they are not accompanied by policies promoting stable tenure. Rationalized tax incentives (e.g. proportionate to the number of planted trees, as in Ethiopia) can also provide an important incentive for participation (Nawir *et al.* 2007). However, it is critical not to ignore the political implications of afforestation programmes in rural areas: particularly

in regions where governments are unpopular, the perception of state participation in establishing long-term rights over land use (i.e. through planting trees) can lead very quickly to the physical destruction of the project (regardless of the financial or amenity incentives available to the community) as an act of resistance to perceived resource expropriation, as in the case of Thaba-Tseka in Lesotho (Ferguson 1990).

Box 3-5: Sappi Forest Products in South Africa

Originating in 1983, Sappi Forest Products (along with its competitor Mondi Forest Products) has promoted outgrower plantations of eucalypts on a contract basis. More than 10,000 smallholders, over 80% of whom are women, participate in plantations covering at least 13,000 ha in the communal lands of KwaZulu Natal (Nawir *et al.*, 2007).

Sappi Forest Products provides free seedlings, technical assistance through extension services, interest-free loans for establishment, a guaranteed market and cash advances on payment before harvest. The spin-off benefits for employment in the region have also been significant, with local contractors hiring at least 1,000 people for planting and harvesting, and promoting the creation of other local businesses (FAO, 2006). The capital assistance, guaranteed markets and interest-free advanced payments provide important incentives for outgrowers to ensure that they are willing to make the 6-8 year commitment to grow trees on potential farmland, as well as a company commitment to bear all harvesting and transportation costs. In periods of over-supply Sappi has introduced a quota system giving contracted growers first priority for purchase over independent growers, whereas in periods of low supply some growers have preferred to sell their timber independently at the prevailing market price (Nawir *et al.*, 2007).

Sappi has combined these efforts with FSC certification, adding additional corporate benefits to the arrangement through increased market access.

3.6.E. RURAL DEVELOPMENT PROGRAMMES

It must be remembered that an enabling environment for profitable forest management is promoted for a reason, and throughout Africa this is most often as part of a rural development programme. This element of promoting SFM requires a particular focus, given that so many policies to promote an enabling environment for forestry (such as legislative reform, commercial plantation establishment and park enclosures) actually act against the interests of the rural poor, notably through limiting livelihood-generating activities and promoting political marginalization (Agrawal *et al.* 2008; Jindal *et al.* 2008).

While each of the aforementioned policies (tenure reform, legislative reform, market-based policies, corporate-community partnerships) can be seen as part of a suite of actions to promote rural development, two that have yet to be discussed are the promotion of agroforestry, and facilitating the sale of NTFPs. Each of these is directed towards increasing the value of forests and treed landscapes to encourage activities which protect them.

PROS AND CONS OF AGROFORESTRY

A large literature and experience in agroforestry promotion exists, and it is not necessary to repeat it here. Briefly, improved fallows, home gardens, alley cropping, multi-storey crop management, boundary planting, orchards, woodlots, windbreaks, hedges, live fences, fodder banks and trees on pasture can provide a wide array of amenity, productivity, nutritional and diversification benefits to small-scale farmers (FAO 2006).

The economic viability of agroforestry, however, depends upon whether the added costs of tree management result in noticeable improvements in the productivity of smallholder agriculture, particularly in the form of enhanced food security (Dewees 1995). Stable and increasing market prices for crops, in addition to access to extension service personnel, have been shown to significantly increase the profitability of agroforestry, and while there is little that governments can contribute to the former without introducing a host of other problems, the latter should be part of any programme to promote an enabling environment for small-scale tree management (Molua 2005).

The outcomes of agroforestry programmes have been inconsistent and frustrating in many parts of the world, with individual farmers and communities responding to similar incentives with very different tree-growing strategies: two farmers may eagerly respond to the provision of seedlings for agroforestry, but one will clear the trees at a very young age for fuelwood, while another will establish a long-lived windbreak. This is a reflection of heterogeneous resources and livelihood strategies as well as differences in household-level benefits relative to alternatives for meeting livelihood objectives (Scherr 1995).

The overall profitability of agroforestry is often secondary to meeting other objectives: growing trees for livelihood savings will be attractive to farmers who have no better savings strategy, but for those successfully practicing a savings-generating strategy (e.g. off-farm labour or crop sales), growing trees will not be attractive. Also, remember that incremental adoption and adaptation is an important means for farmers to reduce the risk of new agricultural practices (which has been long demonstrated in, for instance, Kenya) – meaning that agroforestry-promoting programmes are likely to have initially low levels of participation, and slow adoption, regardless of the inherent profitability of the scheme (Scherr 1995).

Box 3-6: Fodder shrubs in Kenya

Approximately 80% of central Kenyan households have at least one dairy cow, and both quantity and quality of forage is a significant constraint on yields. A series of farmer-designed and managed trials (sponsored by the Kenya Agricultural Research Institute, the Kenya Forestry Research Institute and the World Agroforestry Centre) demonstrated that *Calliandra calothyrsus* not only provided high protein fodder, but also provided erosion-controlling functions and did not compete with coffee, maize or beans when cropped at 1 m and when established on the internal and external boundaries of fields.

Maintaining 500 shrubs is enough to maintain a single dairy cow sustainably, and added between US\$98-124 to annual incomes. While initially practiced on a small scale (less than 1,000 farmers) for the first 8 years of the project, a plan to scale up to 625,000 participants was initiated (in 1999). By 2003, participation had expanded to 22,000 farmers in Kenya, with nursery establishment, information services and extension being funded by a range of NGOs and international research agencies.

Particular policies that have been critical elements in project success include early input from farmers, farmer-led research trials, techniques based on existing practices, and the use of locally appropriate extension services (through NGO staff and village-based farmer development groups common in central Kenya) (Franzel *et al.*, 2004).

PROS AND CONS OF NTFP-BASED DEVELOPMENT

Promoting markets for NTFPs has emerged as an important theme in improving the sustainability of rural livelihoods while promoting an enabling environment for SFM.

NTFPs naturally recommend themselves to development efforts, given that they are recognized as the most important determinant of livelihood sustainability among many poor households in forested areas (Uma Shaanker *et al.* 2004). Furthermore, NTFPs can simultaneously fulfill two common livelihood strategies: the coping strategy (NTFP sales and consumption can provide a critical financial/nutritive supplement when agricultural output is low) and the diversification strategy (since NTFPs are often harvested from communal land, they are a risk-free asset) (Delacote 2007).

It has been commonly argued that by improving the market access of rural communities and providing means to commercially market NTFPs, that SFM and rural development can be facilitated (see the following example). However, it has been repeatedly demonstrated (e.g. in Rondonia, Brazil by Shone and Caviglia-Harris 2006) that while diversification is promoted through NTFP harvesting, there is little evidence that income increases generated by consumption and marketing of NTFPs compensate for the opportunity costs associated with not converting available forest land to agriculture or pasture.

Furthermore, arguments in favour of increasing market access by rural communities are often disingenuous: throughout much of Africa, NTFPs have been marketed, on at least a weekly basis, for many generations. “Increasing market access” is frequently coded language for “road building” with the implicit interest of centralizing resource management under state government control (Ferguson 1990). New policies to promote the commercialization of NTFPs should carefully examine a) whether commercialization has already occurred and b) if it has not, whether the NTFPs in question can be sustainably harvested at higher rates than currently practiced.

Box 3-7: Village Tree Enterprise Project in Burkina Faso

NTFPs form a critical part of the income of rural people, particularly women, in Burkina Faso. The Village Tree Enterprise Project (VTEP), funded by TREE AID (a UK NGO) aims to facilitate market access for NTFPs in villages throughout Sahelian Africa, but especially in Burkina Faso (Hill *et al.* 2007).

Beginning in 2005, 164 product interest groups have since been formed in Burkina Faso, with a total membership of 1,735, based on 17 different NTFPs (such as Baobab seeds, tamarind fruit, shea butter and gum Arabic) derived from 9 tree species. The first two years of the project have revolved around the submission of draft plans from participating villages.

Although VTEP documents are optimistic about the future of the programme, they also give hints that the project faces a difficult road. First, of the 164 project proposals, at least 147 are for products that are already commercialized throughout Burkina Faso. Furthermore, 159 of the groups seek loans for working capital. Given that these products are commercialized throughout rural Burkina Faso, exactly what additional “working capital” is required is unclear. Finally, it is clear that a common project proposal involves the establishment of fruit-tree orchards by women – project documents acknowledge that this is challenging given that “it is difficult for individual women to establish secure land tenure.” It seems plausible that this commercialization project has become a pawn in a conflict over the gendered elements of land tenure, as other development projects have in the past (Ferguson, 1990).

3.7. WHAT FINANCIAL TOOLS ARE AVAILABLE TO FUND THESE POLICIES?

Several carbon financing options are available to fund these SFM-enabling actions in a CDM context, including the World Bank, bio-energy, self-financing and microcredit. These will now be discussed, in

terms of their applicability and the relationship of the CDM to the policies and barriers already noted. It is helpful beforehand to briefly note financing options that should not be used.

User fees, transportation taxes, property taxes and permit fees should not be used to fund any of these measures. These policies are all aimed at promoting a certain type of management that is currently not being practiced: by charging participants for the privilege of participating in the new policies, a significant disincentive to buy-in is created.

3.7.A. THE AFRICAN CDM CONTEXT

With respect to the general CDM context, in 2007, primary transactions in the CDM resulted in transfers of US\$7.5 billion to developing countries, representing 551 MtCO₂e in avoided greenhouse gas emissions. A review of CDM Project Design Documents (PDDs) indicates that the addition of CER revenue adds between 1 and 10% to the IRR of afforestation projects – in several instances providing the additional revenue which changed a potential project from loss-making to profitable (CATIE 2007). Unfortunately, Africa has supplied only 5% of total CER sales, and less than 1% of the global total was sourced from forestry projects (Capoor and Ambrosi 2008). Africa hosts only 105 CDM projects in total, and 75 are in South Africa, Egypt, Morocco, Uganda and Kenya.⁵

The low profile of Africa, and African forestry in particular, in the CDM, has been blamed on the complexity of CDM requirements (specifically for AR requirements), resulting in transaction costs that are simply too high to be overcome in Africa (Aune *et al.* 2005; Jung 2005; Capoor and Ambrosi 2008).

The bare minimum necessary for CDM projects in a given country to be registered is ratification of the Kyoto Protocol and the existence of a functional Designated National Authority (DNA), but even this latter requirement is beyond the institutional capacity of many African governments (Jindal *et al.* 2008).

Other means of promoting CDM AR activities in Africa, such as reducing transaction costs through simplified modalities and procedures, have yet to make an impact, and have not increased the volume in the project pipeline (Jindal *et al.* 2008). Programmatic options (that is, involving generic changes to rules and incentives as opposed to the project-based approach) have some promise, in that they respond to several current weaknesses in the CDM AR approach by opening areas to AR activities that would otherwise be excluded, resisting the ‘projectization’ of carbon management (which implies suspension of normal politics, social life and economics temporally and spatially and is therefore inherently unsustainable), and thereby offering more opportunities for both synergy with broader development actions and permanent increases in carbon at a regional scale, rather than over only a few thousand hectares (van Noordwijk *et al.* 2008). At the same time, however, a programmatic approach is even more dependent on well-functioning government institutions.

The most important element necessary in encouraging either small-scale or large-scale land and forest managers to engage in carbon-enhancing practices is that such an action is profitable. This has yet to be convincingly demonstrated in sub-Saharan Africa (Perez *et al.* 2007), unless transaction costs are ignored (e.g. Sathaye *et al.* 2001) or monetized reduced emissions from deforestation and degradation (REDD) are assumed (Jung 2005). While REDD holds great promise in Africa, leading some analysts to predict that through this project type alone Africa will be a more important host to CDM projects in the near-future than China, the incorporation of REDD into future climate change treaties is as yet uncertain (Jung 2005). Furthermore, it appears that the inclusion of REDD will be

⁵ www.cdmpipeline.org, June 2009

based both on national programmes and pre-existing UNFCCC methodologies, which are currently not acting to promote African participation (Sanz and Wong 2008).

3.7.B. WORLD BANK FUNDING

The World Bank currently funds 12 carbon sequestration projects in Africa, 7 through the Bio-Carbon Fund and 4 through the Global Environment Facility (GEF). As such, it is the single largest carbon investor in Africa, though these investments are less than 10% of its total global carbon portfolio (Jindal *et al.* 2008). However, it should be noted that the project portfolio for the majority of Bio-Carbon Fund projects (through which the WB directs its funds focused on forest and agroecosystems) has already been filled, and is closed to new fund participation. A new Forest Carbon Partnership Facility (FCPF) has been established, making approximately US\$300 million available, but its funding will be limited to REDD projects. CDM project developers should consider available WB programmes in initial discussions of carbon finance.

The other major REDD funding platform is the UN-REDD Programme. Launched in September 2008, this collaborative partnership between three UN agencies (FAO, UNDP and UNEP) was created specifically in response to, and in support of, the UNFCCC decision on REDD at COP 13 and the Bali Action Plan. With a mandate to “to develop capacity to reduce emissions from deforestation and forest degradation and to implement a future REDD mechanism in a post-2012 climate regime”, the UN-REDD Programme has to date secured US\$52 million to support nine countries to prepare for REDD. In March 2008, it approved a total funding allocation of US\$ 18 million for the Democratic Republic of Congo, Indonesia, Papua New Guinea, Tanzania and Viet Nam.⁶

Since many of the policy suggestions made in this document have REDD implications, the FCPF and the UN-REDD Programme could be a valuable source of funding.

3.7.C. BIO-ENERGY

In addition to their use as household fuelwood, forest products (and most commonly, residues from the forest products industry) have been combusted in boilers to generate heat and power for decades (Bridgwater 2006). While most commonly this heat and power is consumed by the forest products industry itself, if an enabling regulatory environment exists, excess power can be sold into the existing energy grid. Throughout northern Europe, heat and power are supplied to urban districts from forest biomass combustion. Industrial forestry operations should certainly be encouraged to investigate the opportunities for additional revenue that could be captured from selling excess power into regional grids – policies such as feed-in tariffs, quota schemes and green certificates can be particularly helpful in this regard.

Furthermore, recent advances in applied chemistry have developed combinations of acids and enzymes that can convert wood cellulose into ethanol for a variety of end-uses, including as a biofuel (Charles *et al.* 2007). Unlike residue combustion, however, this technology is still in its nascent stages. Though there are a number of large-scale demonstration facilities, these will likely require at least another decade before they are competitive with fossil fuels (Bridgwater 2006; FAO 2008).

Dozens of CDM methodologies have been developed for projects which reduce emissions from forestry operations, waste management and other biomass intensive activities for which a larger

⁶ See www.unredd.org

market exists than for carbon sequestration via forest management *per se*. This is perhaps the best opportunity for generating CDM assets from forestry projects.

3.7.D. SELF-FINANCING

Many of the policies examined here are designed to be self-financing to a certain extent. PES, for instance, while it often requires initial funding in order to successfully establish baselines, institutional structures and rigorous relationships between management activities and delivered services, is primarily self-financing in the medium and long-term. Similarly, outgrower relationships and certification are premised on the existence of market incentives for participation – if these are absent (i.e. forestry activities cannot be self-financed) then there is little justification for pursuing them. The perceived complexity of CDM projects can be greatly reduced if the project, through sales of its carbon assets, can finance itself.

Co-operatives are one means of facilitating finance through decreasing transaction costs for sequestration projects associated with small-scale forest management. Depending on their institutional development, cooperatives can offer improved services, economies of scale and better access to markets while reducing information asymmetries. For these reasons, cooperative forest management is currently undergoing a renaissance in Western Europe, Japan, Australia and the United States.

Cooperatives fail when perceived costs outweigh perceived benefits, particularly if membership commitments are inflexible, but also if internal conflict requires significant negotiation. A particularly important perceived cost is the loss of control over property rights – if land managers feel that their participation involves relinquishing control over previously held rights, they will be reticent to participate. Recent experience with start-up cooperatives suggests that extensive grants from public and private institutions may be necessary in the absence of a well-financed entrepreneur (Hull and Ashton 2008).

3.7.E. MICROFINANCE

For small-scale forest management facilitating policies oriented towards generating sustainable outcomes via the CDM (such as agro-forestry and NTFP marketing facilitation) microfinance may be an important financing option. A significant body of literature and experience exists on this subject, so this discussion will be limited to forest-specific interventions.

Small-scale forest managers are likely to face significant difficulties in accessing financial services, and typically require short-term loans to purchase fertilizer, labour and seedlings to finance storage, processing and equipment leasing and to smooth consumption and uneven cash flows (FAO 2005b). The FAO Microfinance and Forest Based Small-Scale Enterprises guide describes the experience of NTFP-based microenterprises in Sudan based on traditional Islamic financial instruments called the Elmirehbiba Gum Arabic Producers Association (EGAPA).

In spite of a well-planned project design that is compatible with local cultural realities, EGAPA's microfinance performance has been disappointing, primarily because EGAPA's members have failed to contribute to the revolving savings fund that was envisioned to be the primary support of forest lending activities. EGAPA seems to be viewed by its members more as a means of access to external funding than as a legitimate financial institution. In this way, it is reminiscent of the VTEP project in Burkina Faso, or the Thaba-Tseka project in Lesotho (see Ferguson 1990), in that it serves a very important service to its targeted community, but not the service that its original designers envisioned.

The FAO Market Analysis and Development (MA&D) toolkit is a hopeful development in this area. It is designed to promote sustainable development (through resource, market, social and technical

sustainability goals) through a three-step participatory approach to establishing community-based natural resource management projects (see FAO 2006).

It has been practiced in a number of forestry contexts, at a variety of scales, including with the Gambian Forestry Department in an effort to generate income from community forests in partnership with FAO. Training of Forestry Department personnel in MA&D techniques resulted in the facilitation of community enterprises in twenty-six villages, and included alliance formation with traders and credit providers, gaining access to valuable financing options for the communities, and resulting in the development of new community enterprises for the sale of fuelwood, logs, arts and crafts, honey and other NTFPs.

This particular case offers a good example of how steps towards decentralization, community/corporate partnerships and income generation can be promoted through public, private and community partnerships across a variety of scales. Similarly, small and medium forest enterprises have proliferated (over 2,500) in Uganda, including timber and NTFP production and processing. The Ugandan experience emphasizes the importance of responding to a clear market demand and avoiding dependence on donor finance and support services (Donovan *et al.* 2006).

3.7.F. CDM FINANCIAL LIMITATIONS ON FORESTRY CATALYZING POLICIES

The discussion of the forestry business model made clear that policies which aim to catalyze forestry in Africa in the context of the CDM must fulfill four criteria: promoting stable and comprehensive tenure, creating governance structures robust to political pressure, increasing the value of standing forests relative to competing land-uses and focusing on local demand for forest products and/or rare wood for export. While a number of hopeful policies have been suggested explicitly linking them with the CDM financial context reveals important underlying tensions.

First, given the difficulties already noted with self- and micro-finance, the current CDM context of low or unproven profitability and high transaction costs makes these options additionally challenging. While they provide the most promising opportunity for keeping projects oriented primarily towards local needs and governance structures, they are the least likely to provide funding adequate for projects of a scale necessary to produce enough offsets such that they are attractive to international buyers. Simultaneously, while World Bank funding offers long-term, stable opportunities to finance large-scale projects, large-scale projects will have to be designed with relatively complex benefit distribution mechanisms if they are to include small-scale producers, or will be less sensitive to local needs or existing tensions in forest tenure. Community-corporate partnerships may be the most viable opportunity for surmounting this large-scale vs small-scale, global vs local tension.

Second, when considering bio-energy finance, the reforms in national energy policy necessary to generate heat and electricity from the combustion of forest residues on a scale adequate to displace enough fossil-fuel generated energy to represent a sizable volume of offsets will, given current experience, require significant legislative reform. While this should not preclude the effort, it will be challenging for such reform to decrease the regulatory burden while increasing the relative position of small-scale producers (especially in the project demonstration stage) that Section 3.6 has demonstrated is necessary for longterm success. Given that this legislative reform will be further complicated by ensuring its compatibility with existing CDM bio-energy methodologies, such an effort will require significant administrative discipline to remain responsible to community level needs.

Third, and most important, given the as yet marginal (at best) profitability of CDM forest offset projects in Africa, it seems unlikely that carbon revenues in and of themselves will convince large or small-scale forest managers that a CDM project would increase the value of forests relative to other land uses. As such, solely carbon oriented CDM forest projects are unlikely to be particularly

successful. This will require coupling CDM projects with other development initiatives such as a broader PES or NTFP project to supplement carbon returns with additional revenues. While delivering potentially high development benefits, larger, integrated projects will increase the difficulty in ensuring compliance with CDM methodologies by introducing competition between carbon management oriented practices and those which would increase the benefits of a different element of the project (for instance, transportation emissions from marketing goods).

While multiple opportunities to attract financing for forestry catalyzing CDM projects exist, a closer look at their implications reveals that they generate additional complexity for policy and project designs for which decreasing complexity is a critical component to success.

3.8. CONCLUSIONS

The forestry business model is driven by competition in supply, competition in land-use and competition between property rights regimes. Forestry management and regulation is under pressure to become more focused on market-like instruments, to decentralize towards community management, and to require greater participation in governance from large-scale concessionaires.

Put together, this business model and this trend in regulation opens up a number of policies that can be pursued to create an enabling environment for SFM. These include tenure reform, legislative reform, forest certification, PES, community-corporate partnerships, agroforestry and NTFP-based rural development.

Each of these offers pros and cons in the way that they enable profitable forest management. Funding sources are available for each – though the most promising are at least partially self-financing, and each significantly increase project complexity when considered in a CDM context.

Critically, each are subject to important social, economic, political and environmental realities that will be strongly determinative of their success, and therefore can only be applied with any reasonable hope of success after a rigorous investigation of local conditions has been accomplished.

3.9. REFERENCES

- Agrawal, A., Chhatre, A., and Hardin, R. (2008) Changing governance of the world's forests. *Science* 320: 1460-1463.
- Ahas, R., Hain, H. and Mardiste, P. (2006) Estonia. In *Confronting Sustainability: Forest Certification in Developing and Transitioning Countries - Yale F&ES Publication Series Report # 8*. Cashore, B., Gale, F., Meidinger, E., Newsom, D. (eds). New Haven: Yale University.
- Aune, J., Alemu, A., Gautam, K. (2005) Carbon sequestration in rural communities: is it worth the effort? *Journal of Sustainable Forestry* 21(1): 69-79.
- Besley, T. (1995) Property rights and investment incentives: theory and evidence from Ghana. *Journal of Political Economy* 105(5): 903-937.
- Bliss, J. and Kelly, E. (2008) Comparative advantages of small-scale forestry among emerging forest tenures. *Small-scale Forestry* 7: 95-104.
- Boyd, E., Gutierrez, M. and Chang, M. (2007) Small-scale forest carbon projects: adapting CDM to low-income communities. *Global Environmental Change* 17: 250-259.
- Bridgwater, T. (2006) Review: Biomass for energy. *Journal of the Science of Food and Agriculture* 86: 1755-1768.
- Capoor, K. and Ambrosi, P. (2008). *State and Trends of the Carbon Market 2008*. Washington, DC: World Bank.
- Cashore, B., Gale, F., Meidinger, E., Newsom, D. (eds) (2006) *Confronting Sustainability: Forest Certification in Developing and Transitioning Countries - Yale F&ES Publication Series Report # 8*. New Haven: Yale University.

- CATIE (Centro Agronomico Tropical de Investigacion y Enseñanza). (2007) *Guidebook to Markets and Commercialization of Forestry CDM Projects*. Turrialba, Costa Rica: The Tropical Agricultural Research and Higher Education Center.
- Charles, M., Ryan, R., Ryan, N. and Oloruntoba, R. (2007) Public policy and biofuels: the way forward? *Energy Policy*, 35: 5737-5746.
- Delacote, P. (2007) Agricultural expansion, forest products as safety nets, and deforestation. *Environment and Development Economics* 12: 235-249.
- Deweese, P. (1995) Trees on farms in Malawi: private investment, public policy, and farmer choice. *World Development* 23(7): 1085-1102.
- Donovan, J., Stoian, D., Macqueen, D. and Grouwels, S. (2006) *The Business Side of Sustainable Forest Management: Small and Medium Forest Enterprise Development for Poverty Reduction*. London: Overseas Development Institute.
- Dubois, O. (1999) Assessing *Local Resilience and Getting Roles Right in Collaborative Forest Management: Some Current Issues and a Potential Tool, with Special Reference to Sub-Saharan Africa*. IIED: London.
- Dupasquier, O. and Osakwe, P. (2005) *Foreign Direct Investment in Africa: Performance, Challenges and Responsibilities*. Addis Ababa: UN Economic Commission for Africa, African Trade Policy Centre.
- FAO (2005a) Global forest resources assessment 2005: progress towards sustainable forest management. *FAO Forestry Paper # 147*.
- FAO (2005b) Microfinance and forest based small-scale enterprises. *FAO Forestry Paper #146*.
- FAO (2006) Better forestry, less poverty: a practitioner's guide. *FAO Forestry Paper # 149*.
- FAO (2008) Forests and energy: key issues. *FAO Forestry Paper # 154*.
- Ferguson, J. (1990) *The Anti-Politics Machine: "Development," Depoliticization, and Bureaucratic Power in Lesotho*. Cambridge: Cambridge University Press.
- Franzel, S., Denning, G., Lilleso, J. and Mercado, A. (2004) Scaling up the impact of agroforestry: lessons from three sites in Africa and Asia. *Agroforestry Systems* 61: 329-344.
- Frost, P. and Bond, I. (2008) The CAMPFIRE programme in Zimbabwe: payments for wildlife services. *Ecological Economics* 65: 776-787.
- Ham, C. (2006) South Africa. In *Confronting sustainability: Forest certification in developing and transitioning countries - Yale F&ES Publication Series Report # 8*. Cashore, B., Gale, F., Meidinger, E., Newsom, D. (eds). New Haven: Yale University.
- Hamilton, K., Sjardin, M., Marcello, T. and Xu, G. (2008) *State of the Voluntary Carbon Markets 2008*. London & New York: Ecosystem Marketplace & New Carbon Finance.
- Hill, T., Ouedraogo, Y. and Conditamde, L. (2007) Village Tree Enterprise in Burkina Faso – supporting development of small enterprises based on non-wood forest products. *Unasylva* 58: 32-36.
- Hull, R. and Ashton, S. (2008) Forest cooperatives revisited. *Journal of Forestry* 106(2): 100-105.
- Ibarra Gene, E. (2007) The profitability of forest protection versus logging and the role of payments for environmental services (PES) in the Reserva Forestal Golfo Dulce, Costa Rica. *Forest Policy and Economics* 10: 7-13.
- Iversen, V., Chhetry, B., Francis, P., Gurung, M., Kafle, G., Pain, A. and Seeley, J. (2006) High value forests, hidden economies and elite capture: evidence from forest user groups in Nepal's Terai. *Ecological Economics* 58: 93-107.
- Jindal, R., Swallow, B. and Kerr, J. (2008) Forestry-based carbon sequestration projects in Africa: potential benefits and challenges. *Natural Resources Forum* 32: 116-130.
- Jung, M. (2005) The role of forestry projects in the CDM. *Environmental Science & Policy* 8: 87-104.
- Kaipainen, T., Liski, J., Pussinen, A. and Karjalainen, T. (2004) Managing carbon sinks by changing rotation length in European forests. *Environmental Science & Policy* 7: 205-219.
- Kufuor, K. (2004) New institutional economics and the failure of sustainable forestry in Ghana. *Natural Resources Journal* 44: 743-760.
- Larson, A. and Ribot, J. (2007) The poverty of forestry policy: double standards on an uneven playing field. *Sustainable Science* 2: 189-204.
- Molua, E. (2005) The economics of tropical agroforestry systems: the case of agroforestry farms in Cameroon. *Forest Policy and Economics* 7: 199-211.
- Murti, R. and Boydell, S. (2008) Land, conflict and community forestry in Fiji. *Management of Environmental Quality: An International Journal* 19(1): 6-19.
- Mwase, W., Bjornstad, A., Bokosi, J., Kwapata, M. and Stedje, B. (2007) The role of land tenure in conservation of tree and shrub species diversity in miombo woodlands of southern Malawi. *New Forests* 33: 297-307.

- Nawir, A., Kassa, H., Sandewall, M., Dore, D., Campbell, B., Ohlsson, B. and Bekele, M. (2007) Stimulating smallholder tree planting – lessons from Africa and Asia. *Unasylva* 228(58): 53-58.
- Njovu, F. (2006) Zambia. In *Confronting sustainability: Forest Certification in Developing and Transitioning Countries - Yale F&ES Publication Series Report # 8*. Cashore, B., Gale, F., Meidinger, E., Newsom, D. (eds). New Haven: Yale University.
- Oliver, C. and Mesznik, R. (2005) Investing in forestry: opportunities and pitfalls of intensive plantations and other alternatives. *Journal of Sustainable Forestry* 21(4): 97-111.
- Owubah, C., Le Master, D., Bowker, J. and Lee, J. (2001) Forest tenure systems and sustainable forest management: the case of Ghana. *Forest Ecology and Management* 149: 253-264.
- Pagiola, S. (2008) Payments for environmental services in Costa Rica. *Ecological Economics* 65(4): 712-724.
- Perez, C., Roncoli, C., Neely, C. and Steiner, J. (2007) Can carbon sequestration markets benefit low-income producers in semi-arid Africa? Potentials and challenges. *Agricultural Systems* 94: 2-12.
- Roberts, G. (2007) Forest certification faces hard questions. *ENDS Report* 395: 4 p.
- Romano, F. (2007) Forest tenure changes in Africa: making locally based forest management work. *Unasylva* 228(58): 11-17.
- Sanz, M. and Wong, J. (2008) Overview of main views on outstanding methodological issues submitted by Parties and outcomes of SMSTA 28. *Workshop on Methodological Issues relating to REDD in Developing Countries*, 25-27, June 2008, Tokyo, Japan.
- Sathaye, J., Makundi, W., Andrasko, K., Boer, R., Ravindranath, N., Sudha, P., Rao, S., Lasco, R., Pulhin, F., Masera, O., Ceron, A., Ordonez, J., Deying, X., Zhang, X. and Zuomin, S. (2001) Carbon mitigation potential and costs of forestry operations in Brazil, China, India, Indonesia, Mexico, the Philippines and Tanzania. *Mitigation and Adaptation Strategies for Global Change* 6: 185-211.
- Scherr, S. (1995) Economic factors in farmer adoption of agroforestry: patterns observed in Western Kenya. *World Development* 23(5): 787-804.
- Scherr, S., White, A., and Kaimowitz, D. (2003) *A New Agenda for Forest Conservation and Poverty Reduction: Making Markets Work for Low-Income Producers*. Washington, DC: Forest Trends and CIFOR.
- Sen, A. (1999) *Development as Freedom*. New York: Anchor Books.
- Serbruyns, I and Luyssaert, S. (2006) Acceptance of sticks, carrots and sermons as policy instruments for directing private forest management. *Forest Policy and Economics* 9: 285-296.
- Shone, B. and Caviglia-Harris, J. (2006) Quantifying and comparing the value of non-timber forest products in the Amazon. *Ecological Economics* 58: 249-267.
- UNCTAD (1999) *Foreign Direct Investment in Africa: Performance and Potential*. Geneva: UNCTAD.
- Thatcher, T., Lee, D. and Schelhas, J. (1997) Farmer participation in reforestation incentive programs in Costa Rica. *Agroforestry Systems* 35: 269-289.
- Trosper, R., Nelson, H., Hoberg, G., Smith, P. and Nikolakis, W. (2008) Institutional determinants of profitable commercial forestry enterprises among First Nations in Canada. *Canadian Journal of Forest Research* 38: 226-238.
- Uma Shaanker, R., Ganeshaiyah, K., Krishnan, S., Ramya, R., Meera, C., Aravind, N., Kumar, A., Rao, D., Vanaraj, G., Ramachandra, J., Gauthier, R., Ghazoul, J., Poole, N. and Chinnappa, R. (2004) Livelihood gains and ecological costs of non-timber forest product dependence. *Environmental Conservation* 31: 242-253.
- van Noordwijk, M., Suyamto, D., Lusiana, B., Ekadinate, A. and Hairiah, K. (2008) Facilitating agroforestation of landscapes for sustainable benefits: tradeoffs between carbon stocks and local development benefits in Indonesia according to the FALLOW model. *Agriculture, Ecosystems and Environment* 126: 98-112.
- Woodhouse, P. (2003) African enclosures: a default mode of development. *World Development* 31(10): 1705-1720.
- World Bank (2000) *The World Bank Forest Strategy: Striking the Right Balance*. Lele, U., Kumar, N., Husain, S., Zazueta, A. and Kelly, L. (eds). Washington, DC: World Bank.
- World Bank and World Wildlife Fund (1998) *Guidance Note for Improved Forest Management & Certification Target: Achieving the Independent Certification of 200 Million Hectares of Well Managed Production Forests by the Year 2005*. Washington, DC: World Bank.
- Wunder, S. and Alban, M. (2008) Decentralized payments for environmental services: the cases of Pimampiro and PROFAFOR in Ecuador. *Ecological Economics* 65: 685-698.
- Wunder, S., Engel, S. and Pagiola, S. (2008) Taking stock: a comparative analysis of payments for environmental services programs in developed and developing countries. *Ecological Economics* 65: 834-852.
- Zhang, D. and Owiredu, E. (2007) Land tenure, market, and the establishment of forest plantations in Ghana. *Forest Policy and Economics* 9: 602-610.

4. IMPLEMENTING FOREST BIO-CARBON PROJECTS: SUMMARY AND SYNTHESIS OF EXISTING CDM METHODOLOGIES FOR AR AND FOREST BIO-ENERGY

By Mark Purdon

Department of Political Science, University of Toronto

Contact: mark.purdon@utoronto.ca

4.1. ABSTRACT

This chapter summarizes key points of existing forest bio-carbon CDM methodologies, up to date as of July 2009. It discusses technical and administrative issues for eleven large-scale AR methodologies as well as six small-scale AR methodologies that result in net anthropogenic removals of less than 16 ktCO₂e/year. In addition, two small-scale non-AR methodologies involving “non-renewable biomass” are discussed because of their application in improved cookstove projects where the project baseline scenario is fuelwood. Finally, two non-AR large-scale forest bio-energy methodologies are presented, one involving charcoal production and the other fuel-switching to woody biomass. Those interested in forest bio-carbon implementation should also monitor methodologies being developed in the voluntary market, particularly under the Voluntary Carbon Standard (VCS), which is a source of innovation in the field. Trends in both the CDM and the VCS suggest that future bio-carbon methodologies will build in more systemic accounting methods to manage system-wide non-permanence and additionality risks.

4.2. INTRODUCTION

This chapter summarizes key points of existing forest bio-carbon CDM methodologies, up to date as of July 2009. To the uninitiated, forest biocarbon projects methodologies appear complex. Eyes glaze over as one confronts a bewildering array of equations and technical jargon. This chapter aims to dispel some of the technical mystery surrounding the methodologies under the Clean Development Mechanism (CDM) for afforestation/reforestation (AR), improved cookstove and forest bio-energy projects. It also refers to guidelines under the Voluntary Carbon Standard (VCS 2008) for Agriculture, Forestry and Other Land Uses (AFOLU). At the time of writing, however, methodologies for AR or other bio-carbon sinks developed independently of the CDM have not been approved by the VCS, though the area is developing rapidly.

CDM methodologies are important because they are basically project templates. The CDM is built on a “learn-by-doing” basis: project proponents develop methodologies specific to the conditions of their project, after which these methodologies are made publicly available with the intention that they will be used to facilitate the design of future projects.

The chapter considers technical and administrative issues for eleven large-scale CDM AR methodologies, as well as six small-scale AR methodologies (UNFCCC 2007a). In addition, two small-scale AR methodologies involving “non-renewable biomass” are discussed because of their application to improved cookstove projects where the project baseline scenario is fuelwood. See Table 4-1 and Table 4-2 for a list of approved CDM AR and non-AR forest bio-carbon projects. See Table 4-3 and Table 5-4 for a comparison of the main elements of these methodologies. All of the CDM methodologies are available on the UNFCCC website.⁷ The chapter also discusses guidelines for afforestation/reforestation & revegetation (ARR), improved forest management (IFM) and reduced emissions from deforestation and degradation (REDD) produced by the VCS.

The chapter is not intended to replace expert technical advice but, instead, to serve as a summary and synthesis of forest bio-carbon methodologies for those who are interested in undertaking a project and would welcome a gentle introduction. It is written in a manner that borrows from the language of the CDM (“CDM-speak”) to permit easy consultation of the methodologies, but seeks to interpret the technical and administrative complexity in a more straightforward manner. For more detailed explanation of the terms described here, please consult the *CDM Rulebook* on-line.⁸

Some readers might notice a lack of discussion about the socioeconomic impact of bio-carbon projects here, particularly in terms of their contribution to sustainable development. Such issues in the CDM are largely dealt with in the Project Design Document (PDD), where there are sections that need to be completed by the project developer regarding environmental and socioeconomic impacts, as well as a summary of stakeholder comments (CDM EB 2008a, b). Such issues, however, largely fall outside of the methodologies summarized here, which focus on carbon accounting. The only specific mention of community development in the CDM is in the guidance for small-scale reforestation projects. It stipulates that these projects must be “developed or implemented by low-income communities and individuals as determined by the host Party” (UNFCCC 2005c: para 1(i)).

⁷ <http://cdm.unfccc.int/methodologies/index.html>

⁸ <http://cdmrulebook.org/home>

Table 4-1: Approved large-scale CDM AR and consolidated AR methodologies (July 2009)

Methodology Number	Scale	Methodology Title	Baseline Approach	Date of Initial Approval	Number of Projects Using Methodology
AR-AM0001	Large-Scale	Reforestation of degraded land (v. 2)	22(a)	2005	7
AR-AM0002	Large-Scale	Restoration of degraded land through afforestation/ reforestation (v.2)	22(a)	2006	2
AR-AM0004	Large-Scale	Reforestation or afforestation of land currently under agricultural use (v.3)	22(a)	2006	4
AR-AM0005	Large-Scale	Afforestation and reforestation project activities implemented for industrial and/or commercial uses (v.3)	22(c)	2006	5
AR-AM0006	Large-Scale	Afforestation/reforestation with trees supported by shrubs on degraded land (v.2)	22(a)	2007	/
AR-AM0007	Large-Scale	Afforestation and reforestation of land currently under agricultural or pastoral use (v.5)	22(a)	2007	/
AR-AM0008	Large-Scale	Afforestation or reforestation on degraded land for sustainable wood production (v.3)	22(a)	2007	/
AR-AM0009	Large-Scale	Afforestation or reforestation on degraded land allowing for silvopastoral activities (v.4)	22(a)	2007	/
AR-AM0010	Large-Scale	Afforestation and reforestation project activities implemented on unmanaged grassland in reserve/protected areas (v.3)	22(c)	2007	1
AR-ACM0001	Consolidate Large-Scale	Afforestation and reforestation of degraded land (v.3) ⁹	22(a)	2008	5
AR-ACM0002	Consolidate Large-Scale	Afforestation or reforestation of degraded land without displacement of pre-project activities (v.1) ¹⁰	22(a)	Expected 2009	/

⁹ But based on pre-existing methodologies AR-AM0003 “Afforestation and reforestation of degraded land through tree planting, assisted natural regeneration and control of animal grazing” and AR-NM0032-rev “Restoration of degraded soils under grassland through afforestation and reforestation”.

¹⁰ But based on pre-existing methodologies AR-AM0001 & AR-AM0008

Table 4-2: Approved small-scale AR methodologies and forest bio-energy methodologies (July 2009)

Methodology Number	Scale	Methodology Title	Baseline Approach	Small-scale Limitation	Date of Initial Approval	Number of Projects Using Methodology
AR-AMS0001	Small-Scale	Simplified baseline and monitoring methodologies for small-scale afforestation and reforestation project activities under the CDM implemented on grasslands or croplands (v.5)	22(a)	<16 ktCO ₂ /yr	2007/2005	23
AR-AMS0002	Small-Scale	Simplified baseline and monitoring methodologies for small-scale afforestation and reforestation project activities under the CDM implemented on settlements (v.2)	22(a)	<16 ktCO ₂ /yr	2007	/
AR-AMS0003	Small-Scale	Simplified baseline and monitoring methodology for small scale CDM afforestation and reforestation project activities implemented on wetlands (v.1)	22(a)	<16 ktCO ₂ /yr	2007	/
AR-AMS0004	Small-Scale	Simplified baseline and monitoring methodology for small-scale agroforestry - afforestation and reforestation project activities under the CDM (v.2)	22(a)	<16 ktCO ₂ /yr	2008	/
AR-AMS0005	Small-Scale	Approved simplified baseline and monitoring methodology for small scale afforestation and reforestation project activities under the CDM implemented on lands having low inherent potential to support living biomass	22(a)	<16 ktCO ₂ /yr	2008	/
AR-AMS0006	Small-Scale)	Approved simplified baseline and monitoring methodology for small-scale silvopastoral - afforestation and reforestation project activities under the CDM	22(a)	<16 ktCO ₂ /yr	2009	/
AMS I.E.	Small-Scale	Switch from non-renewable biomass for thermal applications by the user (v.1)	48(a)	<15 MW	2008	5
AMS II.G.	Small-Scale	Energy efficiency measures in thermal applications of non-renewable biomass (v.1)	48(a)	<60 GWh	2008	1
AM0041	Large-Scale	Mitigation of methane emissions in the wood carbonization activity for charcoal production	48(a)		2006	1
AM0042	Large-Scale	Grid-connected electricity generation using biomass from newly developed dedicated plantations	48(b)		2006	2

Table 4-3: Comparison of principal elements of large-scale AR methodologies

		AR-AM0001	AR-AM0002	AR-AM0004	AR-AM0005	AR-AM0006	AR-AM0007	AR-AM0008	AR-AM0009	AR-AM0010	AR-ACM001
NET GHG REMOVALS											
CARBON POOLS											
Above-Ground Biomass		X	X	X	X	X	X	X	X	X	X
*Loss of Above-Ground Biomass Due to Fuelwood Collection		X	X	X	X			X			
*Loss of Above-Ground Biomass Due to Tree Harvesting		X	X	X	X			X			
*Loss of Above-Ground Biomass Due to Disturbance					X			X			
Below-Ground Biomass		X	X	X	X	X	X	X	X	X	X
Deadwood			X				Possible		Possible		Possible
Litter			X				Possible		Possible		Possible
Soils			X			X	Possible		Possible		Possible
ON-SITE GHG EMISSIONS											
On-site Burning Fossil Fuels from Site Burning, Thinning and Logging (CO ₂)		X	X	X	X	X		X		X	
Decline in carbon stock of non-tree veg (CO ₂)			X	X	X						
Burning Biomass (varies among CO ₂ /CH ₄ /N ₂ O)		X	X	X	X		X	X		X	
Fertilizers (N ₂ O)		X	X	X				X			
N-Fixing Species (N ₂ O)											
Livestock Fed with Forage Produced by the Project (CH ₄ /N ₂ O)						X					
Removal of Grassland Vegetation During Site Preparation										X	
Burning of Woody Biomass During Site Preparation (Excluding herbaceous biomass)											X
LEAKAGE											
Leakage Due to Activity Displacement	Grazing			X	X		X				X
	Fuelwood collection			X	X		X				
	Cropland			X							
Use of Timber (Wood Posts for Fencing)			X								
Leakage Due to Forage-Fed Livestock (CH ₄ /N ₂ O)						X					

Table 4-4: Comparison of principal elements of forest bio-energy methodologies

		AR-AM0041	AR-AM0042	AR-AMS.I.E.	AR-AMS.II.G.
EMISSION REDUCTIONS					
EMISSIONS					
	Carbonization (CH4)	X			
	Grid Electricity Generation (CO2)		X		
	Quantity of Biomass Consumed			X	X
	Fraction Non-Renewable Biomass			X	X
ON-SITE GHG EMISSIONS					
	On-site Burning of Fossil Fuels from Site Burning, Thinning and Logging (CO ₂)		X		
	Burning Biomass for Electricity Generation (CH ₄)		X		
	Off-site fossil fuel combustion for transportation of biomass to the project plant (CO ₂)		X		
	Electricity Consumption at Project Site (CO ₂)		X		
	Fuel Consumption at Project Site (CO ₂)		X		
	Fertilizer Production (CO ₂ /CH ₄ /N ₂ O)		X		
	Fertilizer Application (N ₂ O)		X		
	Field Burning of Biomass (CO ₂)		X		
LEAKAGE					
	Increase in emissions from fossil fuel combustion due to diversion of biomass residues from other uses to the project plant		X		
	If new kilns produced, emissions from disposal of the old kilns	X			
	Use/diversion of non-renewable biomass saved under the CDM project by non-project households who previously used renewable energy sources			X	X
	Use of non-renewable biomass saved under the CDM project activity to justify the baseline of other CDM projects.			X	X
	Increase in the use of non-renewable biomass outside the project boundary to create non-renewable biomass baselines can also be potential source of leakage.			X	X

4.3. FOREST BIO-CARBON METHODOLOGIES: WHAT ARE THE POSSIBILITIES?

When referring to forest bio-carbon projects, their scope embraces much more than just trees. As demonstrated in Table 4-3, depending on the specific methodology, carbon pools in AR projects can include above-ground and below-ground biomass (for example, trees) but also forest litter, deadwood and soil carbon. There are also management practices whose emissions need to be considered and subtracted from any gains in bio-carbon sequestration, such as those emissions associated with site preparation—emissions from silvicultural equipment and the clearing of biomass. Depending on the project, there are also indirect emissions that need to be accounted for, such as denitrification from excess fertilization and methane emissions from livestock fed with forage produced by the project. Lastly, the methodologies describe techniques for measuring the impact of the project on GHG emissions outside the project area, a phenomenon known as “leakage”. These include provisions for displaced fuelwood collection, grazing, crop production and timber harvesting.

But AR is not the only type of forest bio-carbon project possible. An important example is the use of small-scale CDM projects to reduce emissions resulting from the consumption of fuelwood, such as through improved cookstoves. Another is the use of improved kilns in the production of charcoal, which result in reduced methane reductions from a more efficient carbonization process. While it is not appropriate to say that all technical or administrative issues have been conclusively resolved, the wide scope of technical issues addressed in existing forest bio-carbon methodologies suggests greater application outside AR. Furthermore, while the debate on REDD and AFOLU in high-level international discussions is generally about their over-arching architecture, much can be learned about their operationalization on the ground from existing AR and forest bio-energy methodologies. For example, a key bio-carbon resource in agricultural systems is soil carbon, a carbon pool currently excluded from the CDM if not undertaken as part of an AR project.

Of course, a key reason for interest in forest bio-carbon is its potential to contribute to sustainable development amongst local rural communities and Indigenous Peoples. Much of the thinking here is about how to structure forest bio-carbon administrative procedures and land tenure arrangements so that forest projects benefit the rural poor. Acknowledgement of the important role of land tenure in forest bio-carbon projects is beginning to make its way into the methodologies, particularly in the context of ongoing discussions about REDD (SBSTA 2008: Annex II, para.7(e); 2009: Annex, preamble and para.3); it appears increasingly likely that local community and Indigenous People’s involvement will, in the future, be expanded in forest bio-carbon methodologies.

4.4. CONDITIONS FOR THE APPLICATION OF CDM METHODOLOGIES

To begin with, how does one know when an approved CDM methodology can be used? Any approved methodology can be used for the development of a new CDM project if the project satisfies specific applicability conditions. If there are conditions specified in a methodology that are *not* relevant to a particular new project, the methodology can still be used provided a full explanation is provided of why the conditions are not relevant. The CDM EB (2008a: Annex 12; 2008b: Annex 12) has developed guidelines for determining a methodology’s applicability, shown in Table 4-5.

Table 4-5: Conditions for application of CDM AR and non-AR methodologies

<p>Conditions for applying AR methodologies (Section C.2. of the AR-PDD)</p> <p>Justify that the characteristics of the project (i.e. the specific way of site preparation, species composition of planted trees, displacement of certain types of pre-project activities) match appropriately with the approaches in the selected approved methodology in terms of availability of data, models/approaches used to estimate changes of carbon stocks.</p> <p>Justify and document the rationales and assumptions in a transparent manner. Explain which documentation has been used to support the justification and provide the references to the documentation or include the documentation as a separate annex.</p>
<p>Conditions for applying non-AR methodologies (Section B.2. of the PDD)</p> <p>Please justify the choice of methodology by showing that the proposed project activity meets each of the applicability conditions of the methodology. Explain documentation that has been used and provide the references to the document or include the documentation in Annex 3.</p>

If the project being developed differs too much from the conditions of the approved AR methodologies, project proponents can develop their own methodologies. Given that the review and approval of new methodologies might take 9-10 months,¹¹ it is in the best interests of project proponents of large-scale projects to utilize the existing approved methodologies for reasons of efficiency.

4.5. MANAGING NON-PERMANENCE

As ecological systems subject to natural and anthropogenic disturbances, bio-carbon sinks are at risk of releasing the carbon they store. Carbon sequestration via bio-carbon sinks is not permanent, which adds another layer of complexity to carbon accounting (Schlamadinger *et al.* 2007). Furthermore, these ecological stresses are expected to increase as a result of climate change (Malhi *et al.* 2002; Malhi and Phillips 2004; Malhi *et al.* 2008). Devising a system to address the non-permanence of forest bio-carbon projects is an important task. However, in terms of the methodologies reviewed here, non-permanence is only an issue for AR methodologies (which claim emissions removals), not for non-AR forest bio-energy methodologies (which claim emission reductions).¹²

In the CDM, non-permanence of AR projects is addressed through the selection of one of two types of ‘expiring CER’ (Kägi and Schöne 2005). Emission reductions generated from AR are effectively leased or rented in one of two forms and must be verified every five years, after which they are re-issued, renewed or replaced. Temporary Certified Emission Reductions (tCERs) expire at the end of the commitment period following the one in which they were issued. After verification, a tCER can either be re-issued (if the sequestered carbon remains intact) or the Annex I buyer must replace the expired tCER with a new tCER or a CER. Long-term Certified Emission Reductions (lCERs) expire at the end of the crediting

¹¹ The average time for general methodology approval is 9-10 months (see ECON Analysis 2005)

¹² The issue of permanence applies only to sequestration projects (those – such as AR – that claim credits for removing carbon from the atmosphere). The distinguishing characteristic of this type of project is carbon storage: credits are claimed for carbon that is removed from the atmosphere and stored elsewhere (e.g. in biomass). It is the vulnerability of the storage mechanism to unexpected carbon release that leads to the permanence problem. ‘Standard’ mitigation projects, such as reducing the carbon emissions from inefficient charcoal production, do not store carbon (they simply reduce its production) and so they are not exposed to permanence issues.

period of the activity for which they were issued (and can, therefore, have a potential life of 60 years in the CDM AR context), but must be replaced in the interim if verification shows that sequestered carbon has decreased. At expiry, both tCERs and ICERs must be replaced with credits of their own kind (e.g. tCERs can be replaced by new tCERs but not by ICERs, and vice versa) or with permanent CERs

The VCS (2008), on the other hand, addresses the non-permanence issue by devising a buffer and risk management system for AR and other biocarbon sink projects (“AFOLU”). This system requires that individual projects maintain adequate buffer reserves of non-tradable carbon credits to cover unforeseen losses. The number of buffer credits that a given project must maintain is based on a risk assessment of the project’s potential for future carbon loss. However, the buffer credits from *all* projects are held in a single AFOLU Pooled Buffer Account with the intention that there is always a net surplus of carbon in the overall buffer despite individual carbon losses. The overall system is subject to periodic inspection (“truing up”) every few years through a review of all existing VCS verification reports for all AFOLU projects. As a result of the buffer and risk management system, a net carbon surplus is retained in the system which allows VCS to claim that such carbon credits are permanent and fully fungible with other credits.

In addition to the VCS proposal, which is unique because of its systemic elements, insurance schemes and risk premiums have also been suggested as ways of managing the temporal complexity of individual bio-carbon sink projects (Galik and Jackson 2009; Subak 2003). Mention should also be made of the “tonne-year” approach (Moura-Costa and Wilson 2000). This observes that CO₂ emitted into the atmosphere has a finite residence time there, after which it is re-absorbed by sinks via the global carbon cycle. If carbon is sequestered in biomass for a length of time equivalent to or longer than CO₂’s atmospheric residence time, then it is as good as a permanent reduction. If this so-called “equivalence time” is 55 years, as suggested by Moura-Costa and Wilson (2000), then 1 tonne of CO₂ stored for 55 years is equivalent to a one tonne permanent reduction. Conversely, 55 tonnes of CO₂ stored in biomass for one year is considered equal to a one tonne permanent reduction. For a number of reasons, mostly due to uncertainties in assessing CO₂ residence times—particularly given anticipated decreasing efficiency in the global carbon cycle’s absorptive capacity (Friedlingstein *et al.* 2006)—the approach was not adopted in the CDM (Maréchal and Hecq 2006).

4.6. BASELINES & ADDITIONALITY

Additionality is perhaps the most important aspect of the CDM as it ensures that the CDM does what it set out to do: reduce the cost of mitigation by allowing industrialized countries to purchase credits representing genuine emission reductions or emission removals. Additionality is defined as follows:

A CDM project activity is additional if anthropogenic emissions of greenhouse gases by sources are reduced below those that would have occurred in the absence of the registered CDM project activity (UNFCCC 2005a: para.43).

Key to additionality is the baseline: “that [which] would have occurred in the absence of the registered CDM project activity”. To facilitate the assessment of additionality, the CDM Executive Board has developed an “Additionality Tool” for CDM projects (CDM EB 2007b) as well as one tailored for AR projects (CDM EB, 2007a). The two are essentially the same, only that the AR Additionality Test requires an additional step to determine if the lands are eligible for AR.

Understanding additionality is important because it provides the basis of many of the current criticisms of the CDM. These argue that many of the carbon credits generated under the CDM are not additional and, therefore, not genuine (Lohmann 2006; Schneider 2007; Wara 2008; Wara and Victor 2008). Credits are being created from projects that would have gone ahead anyway, without the CDM. See Chapter 2 for a more detailed discussion of additionality.

4.5.A. LAND ELIGIBILITY

Land eligibility is the first step in the demonstration of additionality for AR projects. Only lands that were deforested prior to January 1, 1990 are eligible for AR project activities under the CDM (UNFCCC 2005d: para.1(c)). The eligibility of lands for AR project activities can be assessed by consulting aerial or satellite imagery, ground based surveys. The use of participatory methods for determining land eligibility was possible for small-scale reforestation projects until 2006, when this possibility was rescinded (CDM EB 2006b: Appendix A).

Eligible lands need not be in the form of one single, contiguous expanse. All methodologies permit AR project activities to contain more than one discrete parcel of land and a number of CDM AR projects actually contain thousands of small parcels of land, some measuring less than 5 ha each. Land eligibility is, however, contingent upon the definition of “forest” under the Marrakech Accords being met, which defines the range of parameters for a “forest” (UNFCCC 2003: para.1(a)):

- 1) a minimum area of land of 0.05-1.0 hectares;
- 2) with tree crown cover (or equivalent stocking level) of more than 10-30 per cent;
- 3) with trees with the potential to reach a minimum height of 2-5 metres at maturity *in situ*.

The Marrakech Accords also emphasize that young natural stands and all plantations which have yet to reach a crown density of 10-30 per cent or tree height of 2-5 metres are considered “forests”—as are areas normally forming part of the forest area which are temporarily unstocked as a result of human intervention. Within the ranges above, the actual definition of “forest” is stipulated by the DNA of each CDM host country.

In practice, defining the “before 1990” land eligibility provisions of the CDM have proven difficult to implement. Many developing countries simply do not have adequate records. AFOLU guidelines developed by the VCS do away with the “before 1990” land eligibility requirement. In order to be eligible for crediting under the VCS, ARR and ALM project proponents must instead demonstrate that the project area was not cleared of native ecosystems—but no deadline is required.

4.5.B. IDENTIFICATION OF ALTERNATIVE SCENARIOS AND JUSTIFICATION OF BASELINE

The crux of the additionality issue is the hypothetical baseline scenario. The baseline is generally defined as the scenario that reasonably represents emissions by sources or removals by sinks that would have occurred in the absence of the CDM. Accreditation for a CDM project can only occur if the emissions reduced or removed over the course of a project activity are in addition to this baseline scenario. The CDM has developed special rules for determining the baseline.

SELECTION OF BASELINE APPROACH

The first step in justifying the baseline is to select the baseline “approach” for the forest bio-carbon project. There are three approaches to the selection of the most plausible baseline scenario—the reference to “Paragraph 22” and “Paragraph 48”, for AR and non-AR CDM projects respectively, found at the start of methodologies (Table 4-6) (UNFCCC 2003: para.22(a-c)). As will be discussed, the baseline approach is actually more important than it at first appears.

Table 4-6: Baseline approaches for AR and non-AR CDM methodologies

Baseline Approaches for AR Projects	
22(a)	Existing or historical, as applicable, changes in carbon stocks in the carbon pools within the project boundary;
22(b)	Changes in carbon stocks in the carbon pools within the project boundary from a land use that represents an economically attractive course of action, taking into account barriers to investment;
22(c)	Changes in carbon stocks in the pools within the project boundary from the most likely land use at the time the project starts
Baseline Approaches for non-AR Projects	
48(a)	Existing actual or historical emissions, as applicable;
48(b)	Emissions from a technology that represents an economically attractive course of action, taking into account barriers to investment, or
48(c)	The average emissions of similar project activities undertaken in the previous five years, in similar social, economic, environmental and technological circumstances, and whose performance is among the top 20 per cent of their category

Most methodologies approved to date make use of approach 22/48(a) to justify the land-use or emissions status found at the beginning of the project as the baseline. This baseline approach has the advantage of simplifying the monitoring programme because baseline carbon stock changes can be “frozen” for the entire crediting period and do not need to be monitored after the project is established.

Two AR methodologies described here (AR-AM005 and AR-AM0010) use baseline approach 22(c), however. This approach is a little more complicated because it acknowledges that the carbon stocks on the land involved in the project were going to be altered from historical/existing conditions by the implementation of non-CDM activities. Despite this, both of these methodologies state that the ex-ante baseline methodology is valid for the entire crediting period and does not need to be monitored over the project’s lifetime.

Baseline approach 22/48(b) “The average emissions of similar project activities undertaken in the previous five years, in similar social, economic, environmental and technological circumstances, and whose performance is among the top 20 per cent of their category” has only been used in forest bio-energy methodology AM0042. It requires that a scenario similar to that intended by the CDM, yet initiated beforehand, be considered as the baseline. For example, if a piece of land is ripe for reforestation—but no reforestation has yet taken place—the project proponent should consider such business-as-usual reforestation efforts in the baseline determination. In other words, baseline approach 22/48(a) & (c) “freeze” the ex-ante baseline scenario over the entire crediting period, while approach 22/48(b) anticipates a “moving” baseline that has to be monitored ex-post, during the project’s implementation.

IDENTIFICATION OF ALTERNATIVE BASELINE SCENARIOS

With the baseline approach selected, the next step is to describe the most plausible baseline and justify its continuance in the absence of the bio-carbon project by comparing it to other plausible alternative scenarios. The additionality tools require that, as a minimum, the following scenarios be considered:

- 1) Continuation of the current situation or pre-project land use;
- 2) The proposed bio-carbon project performed without being registered as a CDM project;
- 3) Other realistic and credible alternative scenarios to the proposed CDM project that deliver comparable outputs (e.g., cement) or services (e.g. electricity, heat);
- 4) For AR projects, if applicable, forestation of at least a part of the land at a rate resulting from:
 - Legal requirements; or
 - Extrapolation of observed forestation activities in the geographical area with similar socio-economic and ecological conditions to the proposed AR CDM project activity.

AM0042, which sees biomass replacing fossil fuels for electricity generation, requires a more sophisticated analysis of alternative baselines. This is because there are many possible fates of biomass, each which affects emissions for the project. Alternative baselines (and their combination) to be considered include:

- B1) The biomass residues are dumped or left to decay under mainly aerobic conditions.
- B2) The biomass residues are dumped or left to decay under clearly anaerobic conditions.
- B3) The biomass residues are burnt in an uncontrolled manner without utilizing them for energy purposes.
- B4) The biomass residues are sold to other consumers in the market and the predominant use of the biomass residues in the region/country is for energy purposes
- B5) The biomass residues are used as feedstock in a process (e.g. in the pulp and paper industry)
- B6) The biomass residues are used as fertilizer
- B7) The proposed project activity not undertaken as a CDM project activity (use of the biomass residues in the project plant)
- B8) Any other use of the biomass residues

What information is used to justify a baseline? The methodologies do not prescribe this. However, the justification can be based on any data, rationales, assumptions and documentation available. But the justification must be carried out in a transparent manner for verification by a third-party.

Lastly, if the bio-carbon project is already mandated by law or regulation then it is not additional. But, in some cases, laws may be on the books, but not enforced. As in the case of methodology AM0041, it is possible to claim additionality under such circumstances. To do so, it is necessary to show that the relevant legal or regulatory requirements are systematically not enforced and that non-compliance is widespread. AM0041 requires a compliance threshold of 50% during the crediting period.

BASELINES AND THE CREDITING PERIOD

One needs to be clear about how long into the future the baseline projection is being made. This is related to the choice of crediting period – that is, to the period of time in which a CDM project can generate officially-recognised carbon credits. For non-AR CDM projects, the crediting period is 7-years (up to twice renewable) or a single 10-year period. For AR CDM projects, the crediting period is for 20 years (up to twice renewable) or a single 30-year period. Note that when renewing a crediting period, the additionality and baseline assessment needs to be undertaken afresh.

4.5.C. INVESTMENT AND BARRIER ANALYSIS

Once the baseline scenario has been identified, the additionality of the proposed bio-carbon project must be demonstrated. Two related steps designed to achieve this are investment analysis and barrier analysis. However, it is sufficient for the purposes of the Additionality Tool that only one of these analyses be conducted before proceeding.

Investment analysis is intended to demonstrate that in the absence of carbon financing, the bio-carbon project activity would not be viable from a commercial (profitability) perspective. There are three options, as well as a sensitivity analysis, to demonstrate this: cost analysis, investment comparison analysis, and benchmark analysis. Cost analysis is the simple demonstration that the bio-carbon project activity demonstrates no financial benefits other than bio-carbon-related income. The next two options rely on the comparison of project financial indicators (IRR, NPV or cost-benefit ratio) both with and without carbon financing. For investment comparison, if one of the non-AR scenarios has a better indicator, then the proposed bio-carbon project activity cannot be considered financially attractive. Conversely, if the non-biocarbon scenarios have a less favourable indicator than the benchmark, the bio-carbon project is considered financially attractive. Lastly, sensitivity analysis is intended to demonstrate that, under a realistic range of economic assumptions, the results from the three options prevail.

Barrier analysis is intended to demonstrate that, even if a project appears financially attractive without carbon revenues, non-financial barriers act to prevent the project from being implemented.¹³ Barrier analysis relies on both the identification of barriers and the demonstration of their applicability to the bio-carbon project. Barriers might include investment, institutional, and technological barriers as well as barriers related to local tradition, prevailing practice, local ecological conditions, social conditions as well as legal and land ownership conditions. And just to come full circle, there might also be investment barriers. In practice, these conditions will be unique for each project and no methodology has been devised for a specific suite of barriers.

Some examples of investment and barrier analysis from registered CDM AR projects may be helpful. For one registered AR CDM project in China, barriers to the project identified were (i) investment barriers facing local communities in the project area, particularly since

¹³ The classic example of such barriers relates to energy efficiency projects. Many energy efficiency activities make financial sense in and of themselves, even without CDM intervention: the cost savings from installing energy-efficient lightbulbs, for example, can more than justify the up-front investment costs. However, many energy efficiency activities are not implemented because of the presence of barriers: individuals may not act rationally or may be risk-averse, the capital required for up-front investment may not be available, individuals may not be aware of the technology options available to them and so on.

incomes from any proposed AR activity would not accrue until approximately five years after the start of the AR project activity; (ii) technological barriers facing local communities, including techniques for preparing and planting trees; (iii) institutional barriers, particularly the inability of individual household farmers to successfully manipulate the chain from investment to production for traditional forest products; and (iv) market risks associated with traditional timber products, particularly low productivity and transport costs. A registered AR CDM project in Moldova identifies institutional and technical barriers similar to the Chinese project as well as a lack of awareness amongst local communities about the negative impacts of current management practices.

4.5.D. COMMON PRACTICE ANALYSIS

Unless the proposed project type has been demonstrated to be first-of-its kind, investment and barrier analysis are to be complemented with an analysis of the extent to which the proposed project (e.g. technology or practice) has already diffused in the relevant sector and region. This is called “common practice analysis”.

Common practice analysis comprises a review of any other activities in the CDM host country that are operational and also similar to the proposed CDM project. If similar activities are identified, then it is necessary to demonstrate that these did not face the same barriers as the proposed biocarbon project. For example, perhaps similar activities enjoyed certain benefits that rendered them financially/economically attractive (e.g. subsidies or other financial flows) and which the proposed bio-carbon cannot use. If all four (or five steps if doing an AR project) of the Additionality Test are satisfied, then the project proponent can reasonably conclude that the proposed project is additional.

4.7. LARGE-SCALE AR METHODOLOGIES

While no less important than the baseline and additionality determination, the actual method of determining carbon credits (measured in tonnes CO₂ equivalents, tCO₂e) resulting from an AR project appears highly technical. There are two key elements of any methodology: the baseline methodology and the monitoring methodology. The two are quite similar in many regards as both are used to estimate net anthropogenic GHG removals (NAGRS)—the number of carbon credits generated from bio-carbon sink projects. The baseline methodology is used to estimate NAGRS for the PDD, before the project begins; monitoring measure NAGRS through field sampling.

There are many steps that are common to both the baseline and monitoring methodology. Because of this relationship, the baseline and monitoring methodologies can appear to be redundant. As an aid, the methodologies distinguish between “ex-ante” estimations before the project starts for the purposes of developing the PDD and “ex-post” measurements during monitoring. We first approach the baseline and monitoring methodologies as a single integrated methodology and highlight differences afterwards.

4.6.A. OVERVIEW OF BASELINE & MONITORING AR METHODOLOGIES

The baseline methodology for AR projects is undertaken “ex-ante” and may be divided into four principal steps. The first corresponds to the geographical delineation of project boundaries and ex-ante stratification, which serves as the geographical basis for managing the AR project. Also at this stage, carbon pools should be selected. Five carbon pools have been identified for AR projects: above-ground biomass, below-ground biomass, deadwood,

litter and soils. However, not all carbon pools need be accounted for, provided that it can be demonstrated that those omitted will not contribute to net emissions via, for example, soil loss or degradation (UNFCCC, 2003: para.21). This may be preferable where the monitoring of certain pools is costly, though also likely to increase over the project’s lifetime (such as soils). Of course, these pools are also omitted in the calculation of CERs.

This is followed by the steps for assessing the additionality of the baseline scenario relative to the bio-carbon project scenario, which have already been described. The final step is to estimate ex-ante NAGRS for the proposed AR CDM project. This is done by estimating ex-ante baseline net GHG removals and ex-ante leakage and subtracting this from actual (project) net GHG removals, itself determined by summing carbon pools and project-related emissions for each strata. The last step is quality assurance and control. These four principal aspects of the baseline methodology are found in Table 4-7.

Table 4-7: Principal aspects of ex-ante baseline methodology

I. Land Eligibility, Ex-ante Stratification and Carbon Pools	II. Additionality Assessment	III. Estimation of Ex-Ante NAGRS	IV. Quality Assurance and Quality Control
<ul style="list-style-type: none"> • Delineation of project boundary • Ex-ante stratification • Selection of carbon pools 	<ul style="list-style-type: none"> • Selection of most plausible baseline approach • Additionality test 	<ul style="list-style-type: none"> • Estimation of Ex-Ante Baseline Net GHG Removals • Estimation of Ex-Ante Actual Net GHG Removals • Estimation of Ex-Ante Leakage • Estimation of Ex-Ante NAGRS 	

Five principal aspects of the monitoring methodology are identified. The first is to define the monitoring frequency, which may depend on the verification period and ecological rate of change of the carbon pools considered. Second, an initial monitoring effort is required at project initiation, in order to provide a first measure of carbon pools and verify the ex-ante stratification. A close third, carbon pools and on-site GHG emissions are measured through a system of permanent sample plots to create a statistical portrait of the project’s carbon sequestration. Fourth is the measurement of ex-post NAGRS including all carbon pools, on-site emissions as well as leakage—the same equation as specified in the baseline methodology. Finally, a quality assurance and control process needs to be developed in order to ensure that the project is on track, follows clear operating procedures and that the system of permanent sampling plots is representative of the entire project area. These five principal aspects of the monitoring methodology are presented in Table 4-8 below.

Table 4-8: Principal aspects of ex-post monitoring methodology

I. Definition of Monitoring Frequency	II. Monitoring Project Implementation and Stratification	III. Determination of Number of Permanent Sample Plots	IV. Measurement of Ex-Post Net Anthropogenic GHG removals	V. Quality Assurance and Quality Control
	<ul style="list-style-type: none"> Initial monitoring of project implementation Evaluation of ex-ante project boundaries and strata 	<ul style="list-style-type: none"> Determination of statistical variation amongst ex-ante strata Determination of number of plots required 	<ul style="list-style-type: none"> Measurement of Ex-Post Baseline Net GHG Removals Measurement of Ex-Post Actual Net GHG Removals Measurement of Ex-Post Leakage Estimation of Ex-Post NAGRS 	

4.6.B. CALCULATION OF NET ANTHROPOGENIC GHG REMOVALS (NAGRS)

The key calculation that results in carbon credits generated through CDM AR project activities is referred to as *net anthropogenic GHG removals by sinks (NAGRS)*. NAGRS represents carbon sequestration resulting from *actual net GHG removals by sinks* during the course of the project minus *baseline net GHG removals by sinks* minus *leakage*, which is due to GHG emissions increasing outside of the project area as a consequence of the project (UNFCCC 2003: para.1). Equation 1 below decomposes the calculation of NAGRS into its three components.

$$\text{NAGRS: } C_{AR-CDM} = \Delta C_{ACTUAL} - \Delta C_{BSL} - LK \quad (\text{Equation 1})$$

where:

C_{AR-CDM}	NAGRS (tCO₂e/yr)
ΔC_{ACTUAL}	Actual net GHG removals by sinks in tCO₂e/yr: the sum of the verifiable changes in carbon stocks in the carbon pools within the project boundary, minus the increase in GHG emissions by on-site sources that are increased as a result of the implementation of the AR project. So “ ΔC_{ACTUAL} ” really means “ $\Delta C_{PROJECT}$ ”.
ΔC_{BSL}	Baseline net GHG removals by sinks in tCO₂e/yr: the sum of the changes in carbon stocks in the carbon pools within the project boundary that would have occurred in the absence of the afforestation or reforestation project activity under the CDM.
LK	Leakage in tCO₂e/yr: the increase in greenhouse gas emissions by sources which occurs outside the boundary of an afforestation or reforestation project activity under the CDM which is measurable and attributable to the afforestation or reforestation project activity.

Unfortunately, the language used in the methodologies is a little misleading. First, NAGRS needs to be estimated before commencing the project (“*ex-ante*”) for the baseline methodology, as well as after (“*ex-post*”) for the monitoring methodology. Second, the methodologies imply that one measures “actual” net GHG removals and leakage before as well as after the project is implemented. But the determination of “actual” *ex-ante* net GHG removals is only an estimate (based on real data) of net GHG removals resulting from the

project for the PDD. So “ ΔC_{ACTUAL} ” really means “ $\Delta C_{PROJECT}$ ”. Third, the baseline scenario is only ever a counterfactual scenario against which the project is assessed. That is, because the baseline scenario cannot exist at the same time as the project scenario for which it serves as a counterfactual, it can never really be directly measured but only estimated. Equations 2 and 3 are presented below to clarify the language on NAGRS.

Baseline “Ex-Ante” NAGRS: (Equation 2)

$$C_{AR-CDM} = \Delta C_{PROJECT (ESTIMATED)} - \Delta C_{BSL (ESTIMATED)} - LK_{(ESTIMATED)}$$

Monitoring “Ex-Post” NAGRS: (Equation 3)

$$C_{AR-CDM} = \Delta C_{PROJECT (MEASURED)} - \Delta C_{BSL (ESTIMATED)} - LK_{(MEASURED)}$$

The key to NAGRS is stratification, which allows the project area to be grouped into relatively homogenous spatial units (strata), allowing one to reduce the variation of ex-ante estimates and ex-post measurements carried-out across the project area.

STRATIFICATION

Featuring strongly in both the baseline and monitoring methodologies is stratification. This allows the project area to be grouped into relatively homogenous spatial units (strata), allowing one to reduce the variation of estimates and measurements carried-out across the project area (IPCC 2003: Section 4.3.3.2.). It is a common practice in forest inventories, where parcels of land are distinguished according to site-specific ecological conditions such as soil type, climate, altitude, aspect and tree species composition. For example, trees growing on different soils may demonstrate different rates of growth and, therefore, carbon sequestration.

Often statistically significant strata are known from forest management. For instance, the geographical distribution of different soil types is often known and, therefore, one can multiply the average carbon sequestration for each soil-type by its geographical extent to arrive at a more precise estimate of carbon sequestration of the project area. However, the strata for AR projects needs to be confirmed in the initial monitoring effort through the collection of field data from a system of permanent sample plots. While stratification is rather straightforward where only a two or three strata are involved, the statistical and data management requirements become more complicated with each additional stratum, particularly where different strata are “nested” one within the other as sub-strata. The strata are usually summed for different variables, resulting in a somewhat bewildering number of summation equations in the methodologies featuring “ Σ ’s”.

This leads to the question of which and how many strata should be included. Unfortunately, there is no easy way of determining which strata are significant without detailed knowledge of the ecosystem. Often expert advice is required.

Box 4-1: The basics of ex-ante carbon sequestration estimations: modeling techniques and the modeling of forest carbon pools

Modelling Techniques

All of the approved CDM AR methodologies make use of modelling techniques to estimate ex-ante carbon sequestration for each stratum, for both the baseline and project scenarios. The modelling techniques are essentially the same for each stratum and scenario, only the parameters change. This does not mean that modelling is necessarily simple. Carbon sequestration models are essentially equations describing the growth rates or changes in carbon stocks occurring over time in different carbon pools under different conditions, conditions which have been delineated during ex-ante stratification. The correct parameters need to be identified for each of the possible strata.

Broadly speaking, there are two principal modelling techniques: the carbon stock change method and the carbon gain-loss method. Stock change models are essentially spreadsheets devised for each specific project, where the equations are developed for each stratum and conditions. The parameters and growth models are largely derived from forest inventory and management studies and are based on empirical measurements made at two different time periods, which can be developed as biomass expansion factors or allometric equations for trees. Similar equations can be established for other carbon pools.

An alternative is the use of the carbon gain-loss method, such as CO₂Fix. CO₂Fix is a database computer application developed by the European Forest Institute that can be specified for different projects through project-specific parameters.¹⁴ The approach used in this case is to estimate carbon stock changes as the difference between the gain from biomass growth and the loss from harvesting and disturbance. Equations for biomass growth and other carbon pools are obtained from parameters derived from fieldwork or local literature.

While it may be possible to use global and national default parameters for a number of key variables, the approved methodologies suggest that many of these default parameters need to be verified against local conditions, either drawn from the local literature or measured in the field. It should be noted that most empirical studies on tree species performed to date have been conducted on single species, which is generally restricted to applications in plantation forestry. Modelling the growth of more than one species is more complicated, but may be accommodated by modelling species groups (Eba'a Atyi 2000; Peng 2000).

Modelling Forest Carbon Pools

Five carbon pools have been identified for CDM AR projects: above-ground biomass, below-ground biomass, deadwood, litter and soils.

Above-ground biomass is estimated through either allometric equations or biomass expansion factors developed from empirical work, as described above. Below-ground biomass is generally estimated indirectly, through the application of root-shoot ratios to above-ground biomass estimates, tailored to local conditions as necessary.

Methods for the estimation of carbon pools in deadwood, litter and soils are also included in some of the methodologies. The carbon pool of deadwood is estimated by assessing age-specific mortality rates of tree species used for AR and combining it with decomposition rates for timber derived from local ecological studies. As for litter, the methodology described in AR-AM0002 points to the ex-post monitoring method which seeks to measure annual rates of litterfall and its rate of decomposition, apparently because local data are lacking. As for soils, changes in soil organic carbon can be assessed from empirical methods based on research, published data or by comparing non-forested and forested lands in the project area.

¹⁴ To download the model, go to: <http://www2.efi.fi/projects/casfor>

ESTIMATING EX-ANTE BASELINE NAGRS

BASELINE NET GHG REMOVALS

With an understanding of stratification and carbon sequestration modelling, we can now turn to the estimation of net GHG removals in the baseline scenario. This is *estimated* before (ex-ante) the project and, depending on the baseline approach for the methodology, *measured* afterwards (ex-post). As explained above, many of the forest bio-carbon methodologies use baseline approach 22/48(a) & (c), where the ex-ante baseline is “frozen” for the entire crediting period and does not need to be measured during the monitoring period.

Differing from actual (project) net GHG removals, the estimation of net GHG removals only measures carbon pools, not any on-site emissions (which are a result of the bio-carbon project once it is implemented). Finally, forest disturbances or human activities that might reduce carbon stocks are *not* included in the estimation of baseline net GHG removals. This is so as to be conservative, since baseline net GHG removals are subtracted from actual (project) net GHG removals to determine NAGRS. The larger the baseline net GHG removals, the more conservative is NAGRS.

ACTUAL (PROJECT) NET GHG REMOVALS

The actual, or project, net GHG removals by sinks are estimated as net carbon sequestration resulting from the project minus any emissions resulting from the project’s implementation. As an estimation of carbon sequestration into the future, the estimation of ex-ante NAGRS relies heavily upon statistical and empirical models of forest growth and management to model forest carbon pools (see Box 4-1). These models are applied to each of the carbon pools from which carbon credits are to be derived.

However, during the course of the CDM project there may also be forest management activities that, while not resulting in direct emissions, do reduce tree carbon pools—most notably from tree mortality as well as from trees harvested for timber and fuelwood. This might be expected especially for projects that anticipate displacing activities from the bio-carbon project to outside the project area, leading to leakage. Estimations of tree biomass losses from timber harvesting, fuelwood collection and forest disturbance need to be “buffered” in the estimation of above-ground carbon sequestration. These buffers are actually of great importance as they can reduce the burden of estimating leakage—if the buffer is large enough, the project can reasonably claim there will be no leakage from the displacement of these activities because provisions have been made to accommodate them in the project area.

While carbon pools may increase over the project period, bio-carbon projects may also lead to emissions in the project area. These must be subtracted from any estimation of carbon sequestration by the project. Possible emissions include annual fuel consumption taking into account travel distances, vehicle/machine fuel efficiency, machine hours, and timing of the planting and harvesting. Biomass burning might result from site preparation and can be estimated from empirical assumptions of the extent of land prepared (typically assumed to be slash and burn), average above-ground biomass stock and average proportion of biomass burn coupled with biomass combustion factors derived from the *LULUCF Good Practice Guidelines* (IPCC 2003). A methodology for tree fertilization is found in a number of the approved methodologies, in cases where tree establishment on poor soils is an objective. In addition, some of the methodologies anticipate emissions resulting from a decline in non-tree vegetation.

MONITORING EX-POST NAGRS

DEFINITION OF MONITORING FREQUENCY

The monitoring frequency for above- and below-ground carbon pools should be set at five-year intervals. Monitoring may occur more frequently, but a five-year interval would coincide with the required periodicity of verification for CDM AR projects. Because soils change more slowly, they need only be monitored at 10- or 20-year intervals. For management-related activities that lead to on-site GHG emissions and leakage, annual estimates based on management records may be necessary.

STATISTICAL METHODS AND DETERMINATION OF NUMBER OF PERMANENT SAMPLING PLOTS

Ex-post measurement of carbon pools is based on a statistical analysis of carbon stocks measured across a system of permanent sampling plots distributed across the project area. Note that none of the methodologies permit remote-sensing techniques for monitoring changes in carbon stocks. Measurements for most of the carbon pools are required to attain a precision level of $\pm 10\%$ of the mean at the 95% confidence interval.

Another approach, recommended for soils and other carbon pools sampled through destructive sampling, is the more conservative Reliable Mean Estimate (RME). This represents the change in soil carbon associated with the difference between the lower-bounds of the 95% confidence interval surrounding each of the means between sampling efforts. The approach should be used in those instances where one cannot measure the exact same entities at different periods in time. Also, because variability among samples can be high even at small spatial scales, paired samples cannot be reliably employed (IPCC 2003: 4.98 to 4.99).

Key questions are: How to estimate the number of plots to attain this level of statistical precision? And how to assess their correct geographical distribution? Such considerations will greatly affect project costs. The actual number of plots is based on the statistical variation of carbon pools measured within each stratum. If the project has been properly stratified, this variation will have been minimized. This is why stratification is so important—the variation amongst strata is used to estimate the number of sample plots (sample size) required. The variation measured across strata is usually reduced by increasing the number of sample plots because the statistical precision of measurements then increases. However, increasing the number of sample plots also increases project costs. Project proponents will want to reach an acceptable estimate of the actual mean in a cost-effective manner by getting stratification right and minimizing the number of required sampling plots.

It is also important to ensure that the overall project is performing in the manner indicated by the plots. This can be accomplished using indicators of carbon stock changes, such as tree height (IPCC 2003: 4.98). To this end, photographic documentation from field visits as well as aerial photos can be used.

FIELD DATA COLLECTION

Above- and below-ground biomass are estimated by conducting an inventory of tree, shrub and herb biomass for each plot in order to obtain an average for each stratum. This average, obtained for each of the measured carbon pools, is applied to the geographical extent of each stratum across the monitoring area. For trees, diameter-at-breast-height (DBH) and height are recorded, and these are converted into carbon stock estimates through the application of biomass expansion factors or allometric equations as described in Box 4-1.

Large shrubs might be treated in a similar manner. The carbon stock of small shrubs and herbs is generally assessed through destructive sampling (IPCC 2003: 4.98).

Below-ground biomass is calculated as a product of above-ground biomass of tree, shrub and herb components and the root-shoot ratio of the species in the respective components. The ex-post estimate of actual net GHG removals is based on summing the changes in carbon stock changes for each stratum as averaged across sample plots, minus the increase in GHG emissions resulting from project activities. With the exception of the carbon stock of small shrubs and herbs, all other above- and below-ground carbon pools can be calculated directly. This allows for repeated sampling, which is a rather straightforward procedure of measuring the change in carbon stock. One measures a tree at Year 0 and measures it again at Year 5 to determine the change in biomass and, consequently, carbon stock.

Some of the methodologies also monitor deadwood, litter and soil carbon pools. Deadwood is distinguished between standing dead wood, which may be recorded as trees (while assigning it to a decomposition class), and lying deadwood, which is measured by the line intersect method. The two deadwood pools are combined per plot and averaged across the stratum. Litter may be monitored by placing four 30cm circular frames within a small nested plot to collect litter, again averaging plots across each stratum. Finally, soils are monitored by collecting five 30cm soil cores from each plot in order to assess organic carbon content; bulk density analysis is conducted by taking one additional core next to one of organic carbon cores. Mass of carbon per unit volume is calculated by multiplying the carbon concentration (percent mass) and bulk density (g/cm^3). Because of the long time it takes for soil carbon to accumulate, soil carbon is typically measured at the beginning of the project and then at either 10- or 20-year intervals.

MONITORING PROJECT IMPLEMENTATION

Project implementation needs to be monitored, including the project boundary, forest establishment and forest management activities. Field measurements should be made using a Geographical Positioning System (GPS) and stored in a Geographical Information System (GIS). It is also necessary to ensure that planting and regeneration is taking place. Such “survival checking” includes surveying the initial survival rate of planted trees three months after planting and replanting if the survival rate is lower than 90% of the final planting density; final checking should occur three years after planting. Steps should also be taken to ensure that all management activities are monitored, including site preparation, planting, fertilization, thinning, harvesting, coppicing and fuelwood collection, while also checking that any harvested lands are replanted. Lastly, ex-ante stratification needs to be verified. Reassessing the ex-ante stratification over the course of the monitoring period is acceptable if this leads to greater accuracy of monitoring results.

MONITORING ON-SITE EMISSIONS

All of the sources of GHG emissions estimated during the baseline methodology need to be monitored. All approved methodologies monitor fuel consumption of the machinery used on-site, converting this value into GHG emissions through the use of appropriate emission factors. Fossil fuel consumption is generally monitored by tracking fuel consumption or distance travelled (IPCC 2003: 4.109).

As for GHG emissions resulting from the loss of non-tree vegetation and biomass burning (for site preparation), both of these may be monitored using equations established for estimating baseline emissions. The mean above-ground biomass stock per unit area before loss or burning should be measured directly. This may be conducted through a destructive sampling method, sampling a small area ($0.5\text{-}1.0 \text{ m}^2$) to determine biomass and averaging

this across strata. For the loss of non-tree vegetation, it is assumed that all existing non-tree vegetation will disappear and only CO₂ is estimated. Biomass burning relies on a visual estimation of the proportion of each stratum burned, applying appropriate emission factors for CH₄ and N₂O to the biomass estimate.

Finally, N₂O emissions from fertilization are monitored by tracking fertilizer purchases and usage at the project level. Care needs to be taken to distinguish between synthetic and organic fertilizers, which have different emission factors and rates of volatilization.

LEAKAGE

A common concern with AR projects is whether they will lead to emissions outside the project area. This needs to be estimated ex-ante as well as ex-post, during monitoring. Only negative leakage is accountable under the current rules of the CDM: that is, only increased emissions resulting from the bio-carbon project outside of the project area should be accounted for. Positive leakage, which might be thought of as emission reductions or enhanced sinks resulting from the project but outside of the project boundary, are not creditable under the current rules of the CDM.

However, many of the CDM AR methodologies do not anticipate any leakage, essentially by building a leakage “buffer” into the project design to offset leakage risks. Methodologies AR-AM0001, AR-AM0002, AR-AM0004, AR-AM0005 and AR-AM0008 have been designed to accommodate on-site harvesting and fuelwood collection in the estimation of actual net GHG removals. This is done by subtracting the anticipated amount of fuelwood collection from the calculation of above-ground biomass. In AR-AM0001, where the deadwood and litter carbon pools are not measured, the collection of fuelwood from the ground will continue to be permitted. With this buffer, it is thought unlikely that the project will displace pre-existing fuelwood collection and on-site timber harvesting activities outside of the project area.

However, if a methodology anticipates that AR project activities will displace traditional pre-project activities such as cropland use, grazing, timber harvesting or fuelwood collection, these have to be estimated. This might, for example, be the result of fencing to prevent animal grazing and allowing natural regeneration to proceed. Such provisions are provided in AR-AM0004, AR-AM0004, AR-AM0005, AR-AM0007 and AR-ACM0001.

While buffers have been devised for leakage resulting from fuelwood collection and timber harvesting, one shortcoming of current methodologies is insufficient consideration of the need for buffers for croplands. Because many AR projects are implemented adjacent to rural farming communities, more attention needs to be given to demographic changes amongst communities in order to avoid land conflicts pitting carbon versus food.

The specific provisions for measuring leakage are given below.

LEAKAGE DUE TO DISPLACED GRAZING

In terms of grazing, the estimation of leakage is based on the pre-project number of animals. If baseline approach 22(a) has been selected, this number is held constant over the crediting period; only AR-AM0005, which abides by baseline approach 22(c), is designed to accommodate possible changes in animal number and relies on the tool “Estimation of GHG emissions related to displacement of grazing activities in AR CDM project activity”.

In general, the pre-project number of animals should be assessed in the field through interviews with local animal owners, conducting a participatory rural appraisal (PRA), or consulting local records. These should be assessed over a 5-10 year period prior to the CDM

project start date and their average used as the pre-project number of animals. From this data, the number of displaced animals can be estimated, which can be relocated to different types of grazing areas. Information is then collected to estimate biomass consumption of the animals over the project area, any fertilizers or fossil fuels associated with their care and the possible extent of areas where grazing might be shifted (so-called “new grazing lands”). “New grazing lands” distinguish between the shift to unidentifiable lands, croplands, grasslands or forest lands. Distinguishing between the different land-types is important because they are each associated with different carbon pools and carbon storage capacities, and the leakage from displaced grazing is estimated as the equivalent of burning all biomass to clear “new grazing lands”. However, this poses some complexities for firewood collection because it is assumed that the establishment of new grazing lands on forest lands will result not simply in the on-site burning of fuelwood, but its collection—an issue to which we turn in the next section.

For actually measuring grazing leakage, much will depend on when reforested lands are actually able to be used for grazing again. Grazing is possible underneath a forest canopy when the trees themselves are no longer vulnerable to grazing. Because of this, it may only be necessary to measure grazing leakage up to the time when the trees are sufficiently large to be free from grazing. As for the data to be collected, monitoring entails an estimation of the average animal population size present in the project area in order to estimate the number of animals displaced outside the project boundary. This information can be obtained from the survey the project area (or a sample of it) and interviewing animal owners may be necessary. If the number of animals in the project area measured during monitoring is less than when estimated for the baseline, this is assumed to mean that some of the animals have been displaced.¹⁵ Total leakage is based on the number of displaced animals to each land category above.

LEAKAGE DUE TO DISPLACED FUELWOOD COLLECTION

The estimation of the displacement of fuelwood collection begins in similar fashion, with an estimate of the pre-project fuelwood collection within the project area. This is obtained through interviews with local land owners or PRA methods and averaged for the period of 5-10 years prior to the project start date. This information is compared with the amount of fuelwood gathering planned under the CDM project, which has been incorporated into the estimation of actual net GHG removals (as described above). Monitoring leakage from fuelwood collection requires determining the amount of fuelwood gathered from outside the project area during implementation, determined by interviewing households through PRA techniques or field-sampling.

The remaining calculations are fairly straightforward. Only if the estimated amount of fuelwood collected within the project area is greater than that which is to be provided through planned management activities should leakage be calculated. If so, then the calculation itself is a simple biomass expansion factor based on the volume of excess fuelwood gathered within the project area that will be displaced outside the project area.

However, consideration should be paid to the manner by which leakage from grazing displacement is treated when “new grazing lands” are established on new forest lands.

¹⁵ Note that it is assumed here that a reduction in livestock numbers is not due to a shift in agricultural production, such as a shift from livestock to soy/grain production, the service sector or to other employment opportunities.

Recall that the method for estimating grazing displacement assumes that all above-ground biomass on the new grazing lands (including whatever fuelwood might be there) is burned and lost as emissions. However, if fuelwood from these sites is collected, double-accounting could occur whereby fuelwood leakage would be derived from both fuelwood consumption and grazing displacement. To control for this, the volume of fuelwood gathering that is supplied to pre-project fuelwood collectors or charcoal producers from the new grazing lands should be monitored. This is then subtracted from the previous estimate of fuelwood displaced outside of the project in order to arrive at a figure for fuelwood displaced outside of the project area to unidentified areas.

LEAKAGE DUE TO INCREASED TIMBER HARVESTING OUTSIDE OF PROJECT AREA

It is also possible that timber harvesting will take place outside of the project area because of the bio-carbon project. This may result from the use of wood posts used for building fenced enclosures within the project area to protect natural regeneration, wood posts which are obtained from outside the project area. If the timber for fencing is to be obtained from inside the project area, these need to be included in the management activities used in the estimation of actual net GHG removals. Such a calculation, however, is only necessary in the event that such harvesting represents more than 2% of actual net GHG removals (CDM EB 2005a: para.3(b)). To estimate leakage from timber harvesting, at least in the anticipated use of wood posts for fencing, it is necessary to estimate the perimeter of the fence and multiply this by appropriate expansion factors.

LEAKAGE DUE TO FORAGE-FED LIVESTOCK

Methodology AR-AM0006 proposes to increase the income of local communities or to improve the financial revenue stream of bio-carbon projects by intentionally planting forage species amongst trees. The production of forage will support the raising of livestock outside the project boundary, and, as a result, will increase leakage emissions due to enteric fermentation and manure management outside the project boundary. The methodology describes methods for estimating CH₄ emissions from enteric fermentation based on forage production, daily biomass intake of the fed animals—determined from field surveys—and appropriate emission factors. Emissions of CH₄ and N₂O vary amongst different manure techniques. The key parameters are the number of livestock and management techniques, which are associated with different emission factors. The ex-ante and ex-post determinations are based on similar data obtained through household surveys.

LEAKAGE DUE TO DISPLACED CROPLANDS

The final leakage issue considered is leakage due to displaced cropland: that is, farmers leaving their fields, which are on lands expected to become part of the AR project. Given the sensitive nature of food security in many of the areas where AR projects might be implemented, the issue of displaced cropland needs to be undertaken with care—more care than anticipated in the CDM methodologies.

The methodologies identify two alternative approaches to estimate leakage from displaced croplands, at the household or at the community level (the household analysis is only appropriate where continued ownership or occupation of land parcels can be shown). For the ex-ante estimate of displaced cropland leakage, AR-AM0004 suggests interviewing households or communities to determine how much of their cropland will be displaced by the project. As for monitoring, it is suggested that a sample of households and communities be tracked with respect to their land use during the initial 5-year period, until the forest is established.

In practice, however, the boundaries separating a bio-carbon project and cropland are often fuzzy, if not unknown, to local inhabitants and rural community institutions. This can often become a source of conflict between bio-carbon project developers and rural communities (see Lang and Byakola 2006), particularly when food security is a pressing local issue. It would be unjust to insist that local inhabitants compromise their food security for bio-carbon. However, while the AR methodologies suggest buffers for on-site timber harvesting and fuelwood collection, they do not have similar provisions (yet) for cropland displacement. The wise project developer would go beyond the CDM provisions for leakage due to displaced croplands and engage rural communities in participatory planning efforts that anticipate future cropland requirements. While this might be at odds with the prevalence of baseline approach 22(a), which does not anticipate changes in baseline conditions, it is reasonable to anticipate demographic changes amongst rural communities adjacent to bio-carbon projects that might require expansion of croplands.

4.8. SMALL-SCALE AR METHODOLOGIES

4.7.A. KEY ASPECTS OF SMALL-SCALE AR METHODOLOGIES

Small-scale methodologies represent an attempt to reduce transaction costs and the administrative burden of the CDM in order to allow smaller players to enter the carbon market. Implementing a CDM project typically costs in the region of \$40,000-\$200,000 (Lee 2004; UNDP 2006: 44&67). While these costs might be acceptable for large-scale projects, they inhibit the development of small-scale projects which are often assumed to better promote sustainable development, particularly amongst low-income communities or individuals most in need of alternative energy and sources of finance.

To lessen the administrative burden of the CDM, small-scale methodologies:

- make use of pre-defined and simplified methodologies
- permit the bundling of discrete project activities
- streamline the third-party validation procedure
- reduce the fee and time for CDM project registration

Of the simplified procedures, perhaps the most innovative is the ability to “bundle” projects. This allows project to be dispersed between different “project activities” and brought together under a common administrative procedure. Another innovation is to permit the same Designated Operational Entity (DOE) to conduct third-party validation and verification, which needs to be done by separate DOEs in large-scale projects. The provision of ‘pre-prepared’ simplified methodologies, which can be directly used as templates for developing small-scale CDM projects, is also helpful, particularly as they provide many default parameters necessary for calculations. These simplifications of AR methodologies can reduce the total administrative costs for a small-scale project to as little as approximately \$25,000 (Lee 2004: 44). But, in order to enjoy such advantages, small-scale AR projects have to remain “small” and are limited to generating 16,000 tCO₂e per year (UNFCCC 2007a). There are also strict restrictions related to leakage: if the project anticipates significant displacement of pre-project activities (grazing, fuelwood collection, etc.), it cannot apply as a small-scale AR project.

So far, pre-prepared small-scale AR baseline and monitoring methodologies exist for AR projects that take place on grasslands or croplands, settlements, wetlands and lands having low inherent potential to support living biomass, as well as AR for small-scale agro-forestry

and silvopastoralism. Experience with implementation, however, is limited as most of the small-scale AR methodologies have been approved only in the past 2 years.

4.7.B. SIMILARITIES WITH LARGE-SCALE AR METHODOLOGIES

Generally speaking, the technical specifications of large-scale and small-scale project methodologies are similar. The baseline approach is 22(a); a stratification of the project area needs to be conducted with ex-ante and ex-post NAGRS estimated for each stratum; monitoring frequency is set at five-year intervals. Though the small-scale methodologies include their own additionality procedure, the demonstration of land-eligibility and assessment of additionality are essentially the same as for large-scale methodologies, except that barriers due to local tradition, prevailing practice and local ecological conditions are now included.

4.7.C. DIFFERENCES WITH LARGE-SCALE AR METHODOLOGIES

The key distinction of small-scale CDM AR projects is that only above- and below-ground carbon pools are to be measured. Carbon accounting is further simplified by the omission of on-site emissions resulting from the bio-carbon project and the omission of leakage. Leakage deserves special attention, because its presence excludes projects from using small-scale methodologies. Perhaps more helpfully, all the small-scale methodologies include numerous appendices with technical information such as allometric equations and default equations for different geographical zones. The small-scale methodologies provide a host of information for project developers to simplify project design.

The small-scale methodologies also permit three new methodologies: agro-forestry AR (AR-AMS0004), silvopastoral AR (AR-AMS0006), and AR on lands having low inherent potential to support living biomass (AR-AMS0005). The agro-forestry methodology seeks to establish a forest (abiding by the CDM definition) while allowing for the continuation or introduction of a cropping regime under the canopy. The silvopastoral methodology seeks to establish AR projects on degraded croplands or grasslands subjected to grazing, leading to the establishment of a forest in a silvopastoral system. The final methodology seeks to establish forests on sand dunes, bare lands, contaminated or mine-spoiled lands, and highly alkaline or saline soils.

A limiting factor for small-scale projects is confidence that leakage will be insignificant. Leakage need not be estimated or monitored if the CDM project is determined *not* to result in the significant displacement of pre-project activities or people. The problem is that demonstrating that leakage will not be significant is not so simple. The methodologies permit for evidence provided by either scientific literature or by expert judgment. But if this is not available, things become more complicated: the methodologies describe methods for quantitatively monitoring leakage which are actually similar to the leakage assessment for large-scale projects described earlier. For instance, grazing or cropland displacement in ARM-ASM0001 is to be estimated ex-ante and monitored ex-post as the percentage of grazing and cropland that may be affected by the AR project activity. If displacement of either grazing or cropland is less than 10% of the project area, leakage can be set at zero; if it is higher than 10%, then leakage is to be set to 15% of actual GHG removals by sinks. If the ex-ante estimate or ex-post measurement of leakage is greater than 50%, then the project cannot utilise the small-scale methodology.

4.9. FOREST BIO-ENERGY METHODOLOGIES: IMPROVED COOKSTOVES, CHARCOAL AND FOREST BIO-ENERGY

4.8.A. LARGE-SCALE FOREST BIO-ENERGY METHODOLOGIES

Two large-scale non-AR methodologies will be of interest to those involved in forestry and biomass energy. The first proposes improved kilns in charcoal production in order to increase the efficiency of the process and reduce CH₄ emissions (AM0041). The second involves the installation of a new grid-connected power plant that is fired or co-fired with renewable biomass from a dedicated plantation (AM0042). An important distinction from AR methodologies, which lead only to the generation of temporary credits (I-CERs/t-CERs), is that non-AR methodologies lead to the generation of permanent carbon credits ('proper' CERs). To be consistent with our earlier discussion of AR methodologies, these are referred to as emission reductions (ERs):

$$\text{Emission Reductions: } ER_y = BE_y - PE_y - LE_y \quad (\text{Equation 4})$$

where:

ER _y	Emission reductions in year y (tCO₂/yr)
BE _y	Baseline emissions in year y (tCO₂/yr)
PE _y	Project emissions in year y (tCO₂/yr)
LK _y	Leakage emissions in year y (tCO₂/yr)

From Equation 4, we can see that non-AR methodologies are much simpler than AR methodologies. For non-AR methodologies, it is possible to use much of the same data in both the baseline and monitoring methodologies. In AR methodologies, however, the baseline emissions are *estimated ex-ante* and only *measured ex-post*. The reason for this is that with non-AR projects emissions are generally present at the start of the project (e.g. an inefficient power plant emitting GHGs). Emissions can be measured both *ex-ante* and *ex-post* in largely the same way, resulting in the determination of emission reductions. For AR projects, though, the emission removals from sinks (i.e., trees) are not present at the start of the project. Because of this they need to be estimated *ex-ante* through modelling and then measured *ex-post* through a system of permanent sampling plots—two very different methods. Because of this difference between non-AR and AR methodologies, the actual monitoring method is much shorter for non-AR as it is generally a repetition of the ex-ante baseline methods.

Table 4-9: Principal aspects of non-AR methodologies

I. Project Boundary	II. Additionality Assessment	III. Ex-Ante and Ex-Post ER Determination	IV. Quality Assurance and Quality Control
<ul style="list-style-type: none"> Delineation of project boundary 	<ul style="list-style-type: none"> Selection of most plausible baseline approach Additionality test 	<ul style="list-style-type: none"> Baseline Emissions Project Emissions Leakage Estimation 	

The forest bio-energy projects discussed here are not AR methodologies as the emission reductions are not associated with carbon sequestration. However, AM0041 does emphasize that the project will not result in any changes in the type and source of wood for the

production of charcoal—the project only claims credits from CH₄ reductions resulting from improved kilns. On the other hand, for AM0042, emissions associated with the plantation need to be measured. If the plantation is an existing AR CDM project, then all such emissions are accounted via on-site emission accounting methods as described for the large-scale AR methodologies. If the plantation for AM0042 is not an AR CDM project, then emissions need to be calculated:

- CO₂ emissions from fossil fuel consumption during agricultural operations;
- GHG emissions from the production of fertilizer that is used at the plantation;
- N₂O emissions from the application of fertilizer at the plantation;
- CH₄ and N₂O emissions from the field burning of biomass.

The difference is due to whether the project is claiming credits resulting from the switch to fuelwood as a feedstock, in which case emissions need to be measured. If the project is only improving the combustion of biomass, and not changing biomass consumption, then the source of biomass itself does not need to be monitored. In reality, though, the Plantar project (with which the improved kiln methodology AM0041 is associated) is paired with a reforestation project (associated with AR-AM0005).¹⁶ The CDM EB has emphasized that all CDM projects using biomass for energy should account for emissions associated with the production of biomass (CDM EB 2006: para. 38).

BASELINE AND MONITORING EMISSIONS

For AM0041, the baseline is determined by estimating the amount of charcoal to be produced and CH₄ emissions associated with the old and new kilns. The latter is determined through a regression equation expressing the statistical relationship between methane emissions and carbonization. The methodology outlines specific steps for the development of such a regression. This regression is then applied using parameters appropriate to the baseline kiln and then compared to the new CDM kiln. The only data that is required to be monitored is the amount of charcoal produced and whether the new CDM project kiln is used.

Baseline emissions for AM0042 are CO₂ emissions from the displacement of electricity generation in grid-connected fossil fuel fired power plants due to the switch to renewable biomass. Such emission calculations are not so straightforward, for which reason the CDM EB has developed a “Tool to calculate the emission factor for an electricity system”, for use in this and other similar methodologies. The baseline estimation of project emissions is based on:

- Project emissions from firing/co-firing fossil fuels in the project (tCO₂/yr)
- Project emissions from electricity consumption that is attributable to the project (e.g. for mechanical processing of the biomass) (tCO₂/yr)
- Project emissions related to transportation of the biomass to the power plant (tCO₂/yr)
- Project emissions from combustion of the biomass and biomass residues (tCO₂e/yr)
- Project emissions related to fossil fuel consumption at the plantation during agricultural operations (tCO₂/yr)
- Project emissions related to the production of synthetic fertilizer that is used at the

¹⁶ While the improved kiln Plantar non-AR project has been registered, the Plantar reforestation project is currently still at validation.

- dedicated plantation (tCO₂e/yr)
- Project emissions related to the application of fertilizers at the plantation (tCO₂e/yr)
- Project emissions arising from field burning of biomass at the plantation site (tCO₂e/yr)

All of the elements above need to be monitored during the project’s implementation.

LEAKAGE

Leakage is anticipated to be small for AM0041. New kilns do not determine the existence of the charcoal production business activity *per se* since charcoal production occurs, up to a certain point, regardless of the state of the kilns. Because of this, no net changes in GHG emissions attributable to the CDM project are expected to occur outside of the project boundaries. However, if new kilns are constructed for the project, the emissions from disposal of the old kilns should be accounted for as leakage.

Leakage is an important concern for AM0042, however. Leakage here might result from an increase in emissions from fossil fuel combustion or other sources due to diversion of biomass residues from other uses to the project plant as a result of the bio-carbon project. The first step here is to attempt to rule-out the need to estimate leakage, using a “leakage approach” to demonstrate that the biomass residues used in the plant did not increase fossil fuel consumption or other emissions elsewhere. These leakage approaches need to be undertaken in correspondence with the baseline scenario selected for AM0042 (Table 4-10). If project leakage effects cannot be ruled out with one of the approaches above, leakage needs to be calculated. To be conservative, and with variation in the details of the calculation due to the leakage approach adopted, leakage is calculated by transforming the quantity of biomass used in the bio-carbon project into its energy equivalent in gigajoules (GJ) and then multiplying this by an emission factor (CO₂/GJ) for the most carbon-intensive fuel used in the country.

Table 4-10: Correspondence between leakage approaches and baseline scenarios for AM0042

Leakage Approach		Baseline Scenario
L1)	Demonstrate that biomass residues have been dumped and left to decay, land-filled or burnt without energy generation and that this practice would continue in the absence of the CDM project activity, e.g. by showing that in the monitored period no market has emerged for the biomass residues considered or by showing that it would still not be feasible to utilize the biomass residues	B1, B2, B3
L2)	Demonstrate that there is an abundant surplus of biomass in the region which is not utilized. For this purpose, demonstrate that the quantity of available biomass residues in the region is at least 25% larger than the quantity of biomass residues that are utilized.	B1, B2, B3, B4
L3)	Demonstrate that suppliers of the biomass residue in the region are not able to sell all of their biomass residues. For this purpose, project participants shall demonstrate that the supplier of the biomass residue for the CDM project as well as a representative sample of suppliers in the region had a surplus of biomass residues which they could not sell and which are not utilized.	B1, B2, B3, B4
L4)	Identify the consumer that would use the biomass residue in the absence of the CDM project. Demonstrate that this consumer has substituted the biomass residue diverted to the CDM project with other types of biomass residues by showing that the former user	B5

	only fires biomass residues for which leakage can be ruled out using approaches L2 or L3. Demonstrate that the substitution of the biomass residues used in the project activity with other types of biomass residues does not require a significant additional energy input except for the transportation of the biomass residues.	
--	---	--

4.8.B. SMALL-SCALE IMPROVED COOKSTOVE CDM PROJECTS

THE STRANGE HISTORY OF RENEWABLE BIOMASS IN THE CDM

Until 2005, fuelwood projects were permitted as small-scale “non-renewable biomass” CDM projects that proposed the switch from non-renewable biomass to renewable sources of biomass or more efficient fossil fuels. Emissions from the combustion of biomass were the baseline against which the CDM project, using renewable energy technology, was able to be compared. However, in September 2005, the CDM EB formally decided to remove non-renewable biomass as an approved methodology baseline (CDM EB 2005b, c). A fuelwood baseline posed a significant problem because projects reducing fuelwood biomass consumption would lead to avoided deforestation, invalid under the CDM.

This decision did not go without comment and the 2005 COP requested the CDM EB to develop methodologies for small-scale projects proposing the switch from renewable to non-renewable sources of biomass (UNFCCC 2005b: para.30). The subsequent methodologies recommended by the SSC-WG permitted non-renewable biomass consumption to be represented in terms of the baseline emissions associated with the equivalent energy use of fossil fuels (CDM SSC-WG 2006: Annexes 15&16). Observers have emphasized that this significantly underestimates the carbon mitigation potential of such projects in comparison to a fuelwood baseline because fossil fuels actually burn much more cleanly than fuelwood (see responses under UNFCCC 2006a). Despite the recommendation of the SSC-WG, the proposed 2006 methodologies were again rejected by the CDM EB because of the link to avoided deforestation (CDM EB 2006a: para.54). At the 2006 COP, the CDM EB was once again called upon to develop methodologies (UNFCCC 2006b: para. 28&29). This saw the SSC-WG respond by essentially re-submitting its earlier recommended methodologies (CDM SSC-WG 2007: Annex 1&2), which were finally approved at the 2007 COP in Bali as small-scale methodologies AMS.I.E and AMS.II.G (UNFCCC 2007b: para.24).

RENEWABLE AND NON-RENEWABLE BIOMASS

Small-scale methodologies AMS.I.E and AMS.II.G involve, respectively, the switch away from non-renewable biomass or improvement in the efficiency of its use such that less non-renewable biomass is consumed. Technologies typically associated with AMS.I.E. are biogas stoves and solar cookers. For AMS.II.G., anticipated technologies are higher-efficiency biomass-fired cook stoves or improvement of the energy efficiency of existing biomass-fired cook stoves.

A key challenge, however, lies in distinguishing non-renewable biomass from renewable biomass. The methodologies deem “renewable” any biomass which satisfies any one of the five conditions found in Table 4-11. While biomass can be woody and non-woody, the excitement surrounding these methodologies is that they finally permit fuelwood to be used as the baseline. As fuelwood is one of the dominant energy forms amongst the poor (Arnold and Persson 2006; Drigo 2005), it is hoped that these new methodologies might permit the CDM to improve on energy practices amongst low-income communities and Indigenous Peoples.

Table 4-11: Definition of renewable biomass

I)	The biomass is originating from land areas that are forests where: <ul style="list-style-type: none"> • The land area remains a forest; and • Sustainable management practices are undertaken on these land areas to ensure, in particular, that the level of carbon stocks on these land areas does not systematically decrease over time (carbon stocks may temporarily decrease due to harvesting); and • Any national or regional forestry and nature conservation regulations are complied with.
II)	The biomass is woody biomass and originates from croplands and/or grasslands where: <ul style="list-style-type: none"> • The land area remains cropland and/or grasslands or is reverted to forest; and • Sustainable management practices are undertaken on these land areas to ensure in particular that the level of carbon stocks on these land areas does not systematically decrease over time (carbon stocks may temporarily decrease due to harvesting); and • Any national or regional forestry, agriculture and nature conservation regulations are complied with.
III)	The biomass is non-woody biomass and originates from croplands and/or grasslands where: <ul style="list-style-type: none"> • The land area remains cropland and/or grasslands or is reverted to forest; and • Sustainable management practices are undertaken on these land areas to ensure in particular that the level of carbon stocks on these land areas does not systematically decrease over time (carbon stocks may temporarily decrease due to harvesting); and • Any national or regional forestry, agriculture and nature conservation regulations are complied with.
IV)	The biomass is a biomass residue and the use of that biomass residue in the project activity does not involve a decrease of carbon pools, in particular dead wood, litter or soil organic carbon, on the land areas where the biomass residues are originating from.
V)	The biomass is the non-fossil fraction of an industrial or municipal waste.

Distinguishing between renewable and non-renewable biomass is important for determining emission reductions, where the fraction of non-renewable biomass ($f_{NRB,y}$) is integral to the calculation (Equation 5):

Emission Reductions: $ER_y = B_y * f_{NRB,y} * NCV_{biomass} * EF_{projected\ fossil\ fuel}$ (Equation 5)

where:

- ER_y Emission reductions in year y (tCO₂/yr)
- B_y Quantity of biomass substituted or displaced in tonnes (tCO₂/yr) OR Quantity of biomass saved in tonnes (tCO₂/yr)
- $f_{NRB,y}$ Fraction of biomass used in the absence of the CDM project that can be established as non-renewable biomass using survey methods
- $NCV_{biomass}$ Net calorific value of the non-renewable biomass that is substituted
- $EF_{projected\ fossil\ fuel}$ Emission factor for the projected fossil fuel consumption in the baseline.

BASELINE AND MONITORING EMISSIONS

The biomass substituted or saved must be converted into its fossil fuel energy equivalent in order to determine baseline emissions. But the other novelty in the baseline is the need to determine the fraction of non-renewable biomass ($f_{NRB,y}$). Ranging from 0.0-1.0, the fraction

of non-renewable biomass has the capacity to influence the calculation of ERs in an important way. But its determination is far from straightforward. First, in keeping with the eligibility of AR projects, it needs to be demonstrated that non-renewable biomass has been in use prior to 1990. But the actual means of demonstrating that biomass is non-renewable are somewhat underspecified. The methodologies rely on local survey methods which may use, but are not limited to, the following indicators (or their combination):

- Increasing trend of time spent or distance travelled by users for gathering fuel wood;
- Increasing trends in fuel wood price indicating scarcity;
- Trends in the type of biomass collected by users, suggesting scarcity of woody biomass.

The local survey may be complemented by national or local statistics—even remote sensing—as well as historical data.

Monitoring consists of an annual check of efficiency of a representative sample of the improved cookstove to ensure that they are still operating at the specified efficiency or have been replaced. In order to assess leakage, monitoring shall include data on the amount of biomass saved under the project activity that is used by non-project households/users (who previously used renewable energy sources). Monitoring also needs to ensure that the replaced low-efficiency cookstoves are not used.

LEAKAGE

Leakage relating to the non-renewable biomass is assessed in the same way for both cookstove methodologies. The basic technique is to conduct ex-post surveys of users and areas from where biomass is sourced in order to determine one or more of the following potential sources of leakage:

- Use/diversion of non-renewable biomass saved under the CDM project by non-project households who previously used renewable energy sources.
- Use of non-renewable biomass saved under the CDM project activity to justify the baseline of other CDM projects.
- Increase in the use of non-renewable biomass outside the project boundary to create non-renewable biomass baselines can also be potential source of leakage.

All of the sources of leakage identified are to be addressed by adjusting B_y in the calculation of ERs.

4.10. VCS GUIDELINES

The Voluntary Carbon Standard (VCS) is a non-profit organization that is attempting to standardize carbon accounting procedures both under the CDM and other compliance systems. While no VCS-approved methodologies exist for AR other than those already in use under the CDM, the VCS has recently issued guidelines for AR and other AFOLU bio-carbon projects (VCS 2008). We have already discussed the most important provision of the VCS bio-carbon system—its buffer and risk analysis system. At this stage, we briefly discuss what the VCS's AFOLU guidelines envision for future forest bio-carbon methodologies.

The VCS (2008) guidelines for AFOLU differ in an important manner from the CDM in that they will permit not just AR, but the broad spectrum of AFOLU: afforestation/reforestation & revegetation (ARR), improved forest management (IFM) and reduced emissions from deforestation and degradation (REDD). The first, ARR, is similar to CDM AR, but IFM and

REDD are not part of the current CDM. IFM would include: (i) conversion from conventional logging to reduced impact logging, (ii) conversion of logged forests to protected forests, (iii) extending the rotation age of evenly-aged managed forests, and (iv) conversion of low-productivity forests to high-productivity forests.

Such improvements could lead to a potential reduction in the flow of timber off the project site, thereby causing leakage through the displacement of logging activity to other forest areas. The VCS requires that this leakage be accounted for using the leakage table provided in its “Tool for AFOLU Methodological Issues”. With regard to REDD, the VCS will accept credits from projects that: (i) avoid planned deforestation, (ii) avoid unplanned frontier deforestation and degradation, and (iii) avoid unplanned mosaic deforestation and degradation. The distinction between frontier and mosaic deforestation is an important one for baseline considerations. While historic forest conversion rates in mosaic landscapes may provide a reasonable indication of the threat of deforestation, frontier conversion rates are typically very low prior to the incursion of roads and populations. Where baselines are of the 22(a) type under the CDM (existing or historical), this may underestimate future threats to frontier forests. Project proponents may combine a variety of activities spanning the four general AFOLU categories (ARR, ALM, IFM, REDD) into a single VCS project; however, separate methodologies and non-permanence risk assessments must be applied to each project category.

In terms of the socioeconomic performance of VCS forest bio-carbon projects, the guidelines also require the identification of negative environmental and socio-economic impacts and that the project developer take steps to mitigate these impacts. This contrasts with the rather underspecified conditions for socioeconomic and environmental impact analysis in the CDM.

Lastly, the VCS does away with the “before 1990” land eligibility requirement of CDM AR projects. In order to be eligible for crediting under the VCS, ARR and ALM project proponents must instead demonstrate that the project area was not cleared of native ecosystems, such as forests, grasslands, scrublands or wetlands—no specific deadline is required. But, differing from the CDM, where native grasslands can be converted to AR projects, VCS does not permit AFOLU projects that convert native ecosystems to generate carbon credits.

4.11. CONCLUSION

Forest bio-carbon projects using the methodologies described here currently represent less than 1% of total credits generated under the CDM (UNEP Risoe Centre, 2009b). One reason for the slow uptake of AR projects is the complexity of the methodologies and the associated high transaction costs. This chapter hopes to have dispelled some of the mystery surrounding such methodologies and provide some of the conceptual and technical tools for embarking on forest bio-carbon projects.

We can expect to see the UNFCCC continue to seek ways to streamline the CDM process. Small-scale project methodologies have been a first step, but much more hope lies in programmatic CDM and, possibly, a future sectoral CDM. However, there are concerns that CDM AR methodologies do not sufficiently accommodate leakage due to cropland expansion. This is, in part, due to a reliance on baseline approach 22/48(a), which “freezes” the ex-ante baseline scenario for the entire duration of the CDM project. Such a baseline approach is not able to accommodate changes in the baseline scenario that would have occurred anyway, in the absence of the CDM project activity, such as demographic change. A

“moving” baseline might be more appropriate for the better management of leakage as well as additionality.

Lastly, bio-carbon project developers should monitor developments in AFOLU under the VCS, which is a source of innovation in the field. Trends in both the CDM and the VCS suggest that future bio-carbon methodologies will build in more systemic accounting methods to manage system-wide (or at least country-wide) non-permanence and additionality risks.

4.12. REFERENCES

- Arnold, J.E.M., and Persson, R. (2006) Woodfuels, livelihoods and policy interventions: changing perspectives. *World Development* 34: 596-611.
- CDM EB (2005a) *Report of CDM Executive Board, 22nd Meeting, Annex 15: Clarification Regarding Methodologies for Afforestation and Reforestation CDM Project Activities*. Bonn: UNFCCC.
- CDM EB (2005b) *Report of CDM Executive Board, 21st Meeting, Annex 22: Indicative Simplified Baseline and Monitoring Methodologies for Selected Small-Scale CDM Project Activity Categories*. Bonn: UNFCCC.
- CDM EB (2005c) *Report of CDM Executive Board, 20st Meeting, Annex 8 "Clarifications on Definition of Biomass and Consideration of Changes in Carbon Pools due to a CDM Project Activity"*. Bonn: UNFCCC.
- CDM EB (2006a) *Report of the CDM Executive Board, 25th Meeting*. Bonn, Germany: UNFCCC.
- CDM EB (2006b) *Report of Executive Board of the Clean Development Mechanism, 28th Meeting, Annex 18: Revision to Simplified Baseline and Monitoring Methodologies for Selected Small-Scale Afforestation and Reforestation Project Activities under the Clean Development Mechanism AR-AMS0001*. Bonn: UNFCCC.
- CDM EB (2006c) *Report of Executive Board of the Clean Development Mechanism, 25th Meeting*. Bonn, Germany: UNFCCC.
- CDM EB (2007a) *Report of CDM Executive Board, 35th Meeting, Annex 17: Tool for the Demonstration and Assessment of Additionality in A/R CDM Project Activities (Version 02)*. Bonn: UNFCCC.
- CDM EB (2007b) *Report of CDM Executive Board, 39th Meeting Report, Annex 10: Tool for the Demonstration and Assessment of Additionality (Version 5)*. Bonn: UNFCCC.
- CDM EB (2008a) *Report of CDM Executive Board, 41st Meeting, Annex 12: Revision to "Guidelines for Completing the Project Design Document (CDM-PDD), and the Proposed New Baseline and Monitoring Methodologies (CDM-NM) (version 07)"*. Bonn: UNFCCC.
- CDM EB (2008b) *Report of CDM Executive Board, 42nd Meeting, Annex 12: Revision to "Guidelines for Completing the Project Design Document for A/R (CDM-AR-PDD), the Proposed New Methodology for A/R: Baseline and Monitoring (CDM-AR-NM)" (version 9)*. Bonn: UNFCCC.
- CDM Methodology Panel (2008) *33rd Meeting Report, Annex 11: Proposal for an Enhanced Barrier Test for Project Activities That Have a Potentially High Profitability Without CER Revenues*. Bonn: UNFCCC.
- CDM SSC-WG (2006) *Report of 4th Meeting of the Small-Scale Working Group (CDM-SSC-4)*. Bonn, Germany: UNFCCC.
- CDM SSC-WG (2007) *Report of 11th Meeting of the Small-Scale Working Group*. Bonn, Germany: UNFCCC.
- Cosbey, A., Parry, J.-O., Browne, J., Babu, Y.D., Bhandari, P., Drexhage, J., and Murphy, D. (2005) *Realizing the Development Dividend: Making the CDM Work for Developing Countries*. Winnipeg: IISD.
- Drigo, R. (2005) *WISDOM – East Africa: Woodfuel Integrated Supply/Demand Overview Mapping (WISDOM) Methodology, Spatial Woodfuel Production and Consumption Analysis of Selected African Countries*. Rome: FAO.
- Eba'a Atyi, R. (2000) *TROPFOMS: A Decision Support Model for Sustainable Management of South-Cameroon's Rainforests*. Wageningen: Trobenbos International.

- ECON Analysis (2005) *CDM Methodology Status Report 2005*. Washington, D.C.: World Bank Carbon Finance Business.
- Friedlingstein, P., Cox, P., Betts, R., Bopp, L., von Bloh, W., Brovkin, V., Cadule, P., Doney, S., Eby, M., Fung, I., Bala, G., John, J., Jones, C., Joos, F., Kato, T., Kawamiya, M., Knorr, W., Lindsay, K., Matthews, H.D., Raddatz, T., Rayner, P., Reick, C., Roeckner, E., Schnitzler, K.-G., Schnur, R., Strassmann, K., Weaver, A.J., Yoshikawa, C., and Zeng, N. (2006) Climate-carbon cycle feedback analysis: results of the C4MIP model intercomparison. *Journal of Climate* 19: 3337-3353.
- Galik, G.S., and Jackson, R.B. (2009) Risks to forest carbon offset projects in a changing climate. *Forest Ecology and Management* 257: 2209-2216.
- IPCC (2003) *Good Practice Guidelines for Land Use, Land-Use Change and Forestry*. Kanagawa, Japan: IPCC-NGGIP.
- IPCC (2007) *Fourth Assessment Report, Climate Change 2007: Synthesis Report*. Cambridge: Cambridge University Press.
- Kägi, W., and Schöne, D. (2005) *Forestry Projects Under the CDM: Procedures, Experiences and Lessons Learned, Forests and Climate Change Working Paper 3*. Rome: FAO.
- Lang, C., and Byakola, T. (2006) "A Funny Place to Store Carbon": UWA-FACE Foundation's Tree Planting Project in Mount Elgon National Park, Uganda. Montevideo & Moreton in Marsh: World Rainforest Movement.
- Lee, M.-K., (ed) (2004) *CDM: Information and Guidebook*. Roskilde, Denmark: UNEP Riso Centre.
- Lohmann, L., (ed) (2006) *Carbon Trading - A Critical Conversation on Climate Change, Privatisation and Power*. Dorset: Dag Hammarskjöld Foundation, Durban Group for Climate Justice and The Corner House.
- Malhi, Y., Meir, P., and Brown, S. (2002) Forests, carbon and global climate. *Philosophical Transactions of the Royal Society of London Series A* 360: 1567-1591.
- Malhi, Y., and Phillips, O.L. (2004) Tropical forests and global atmospheric change: a synthesis. *Philosophical Transactions of the Royal Society of London Series B-Biological Sciences* 359: 549-555.
- Malhi, Y., Roberts, J.T., Betts, R.A., Killeen, T.J., Li, W., and Nobre, C.A. (2008) Climate change, deforestation, and the fate of the Amazon. *Science* 319: 169-172.
- Maréchal, K., and Hecq, W. (2006) Temporary credits: A solution to the potential non-permanence of carbon sequestration in forests? *Ecological Economics* 58: 699-716.
- Moura-Costa, P., and Wilson, C. (2000) An equivalence factor between CO₂ avoided emissions and sequestration—descriptions and applications in forestry. *Mitigation and Adaptation Strategies for Global Change* 5: 51-60.
- Peng, C. (2000) Growth and yield models for uneven-aged stands: past, present and future. *Forest Ecology and Management* 132: 259-279.
- Pin, K.F. (2005) *The CDM Project Cycle, Transaction Costs and the Role of Institutions*. Selangor Darul Ehsan, Malaysia: Pusat Tenaga Malaysia. Website (accessed 20 June 2009): http://cdm.eib.org.my/useful_materials/Presentation/2.%20Transaction%20Costs%20%20CDM%20%20Fui%20Pin.pdf.
- SBSTA (2008) *Report of the Subsidiary Body for Scientific and Technological Advice on its Twenty-Eighth Session, Held in Bonn from 4 to 13 June 2008*. Bonn: UNFCCC.
- SBSTA (2009) Annex, Draft text for a decision on methodological guidance for activities relating to reducing emissions from deforestation and forest degradation in developing countries. In *Reducing Emissions from Deforestation in Developing Countries: Approaches to Stimulate Action*. Bonn: UNFCCC.
- Schlamadinger, B., Bird, N., Johns, T., Brown, S., Canadell, J., Ciccarese, L., Dutschke, M., Fiedler, J., Fischlin, A., Fearnside, P., Forner, C., Freibauer, A., Frumhoff, P., Hoehne, N., Kirschbaum, M.U.F., Labat, A., Marland, G., Michaelowa, A., Montanarella, L., Moutinho, P., Murdiyarso, D., Pena, N., Pingoud, K., Rakonczay, Z., Rametsteiner, E., Rock, J., Sanz, M.J., Schneider, U.A., Shvidenko, A., Skutsch, M., Smith, P., Somogyi, Z., Trines, E., Ward, M., and Yamagata, Y. (2007) A synopsis of land use, land-use change and forestry (LULUCF) under the Kyoto Protocol and Marrakech Accords. *Environmental Science & Policy* 10: 271-282.
- Schneider, L. (2007) *Is the CDM Fulfilling its Environmental and Sustainable Development Objectives? An Evaluation of the CDM and Options for Improvement*. Berlin: Institute for Applied Ecology.

- Subak, S. (2003) Replacing carbon lost from forests: an assessment of insurance, reserves, and expiring credits. *Climate Policy* 3: 107-122.
- UNDP (2006) *An Assessment of Progress with Establishing the Clean Development Mechanism*. New York: UNDP.
- UNEP Risoe Centre (2009a) *CDM Projects by Host Region*. Roskilde, Denmark: UNEP-Risoe Centre. Website (accessed 2 July 2009): <http://www.cdmpipeline.org/cdm-projects-region.htm#6>.
- UNEP Risoe Centre (2009b) *CDM Projects by Type*. Roskilde, Denmark: UNEP-Risoe Centre. Website (accessed 2 July 2009): <http://www.cdmpipeline.org/cdm-projects-type.htm#6>.
- UNFCCC (2003) *Decision 19/CP.9: Modalities and Procedures for Afforestation and Reforestation Project Activities Under the Clean Development Mechanism in the First Commitment Period of the Kyoto Protocol, Annex: Modalities and Procedures for Afforestation and Reforestation Project Activities Under the Clean Development Mechanism*. Bonn: UNFCCC.
- UNFCCC (2005a) *Decision 17/CP.7: Modalities and Procedures for a Clean Development Mechanism as defined in Article 12 of the Kyoto Protocol*. Bonn: UNFCCC.
- UNFCCC (2005b) *Decision 7/CMP.1: Further Guidance Relating to the Clean Development Mechanism*. Bonn: UNFCCC.
- UNFCCC (2005c) *Decision 5/CMP.1 Annex: Modalities and Procedures for Afforestation and Reforestation Project Activities Under the Clean Development Mechanism*. Bonn: UNFCCC.
- UNFCCC (2005d) *Decision 11/CP.7: Definitions, Modalities, Rules and Guidelines Relating to Land Use, Land-Use Change and Forestry Activities Under the Kyoto Protocol*. Bonn: UNFCCC.
- UNFCCC (2006a) *Call for Public Inputs on Procedures to Address 'Leakage' in Small Scale CDM Biomass Project Activities*. Bonn: UNFCCC. Website (accessed September 16, 2007): http://cdm.unfccc.int/public_inputs/meth_ssc_bio/index.html.
- UNFCCC (2006b) *Decision 1/CMP.2 Further Guidance Relating to the Clean Development Mechanism*. Bonn: UNFCCC.
- UNFCCC (2007a) *Decision 9/CMP.3 Implications of Possible Changes to the Limit for Small-Scale Afforestation and Reforestation Clean Development Mechanism Project Activities*. Bonn: UNFCCC.
- UNFCCC (2007b) *Decision 2/CMP.3 Further Guidance Relating to the Clean Development Mechanism*. Bonn: UNFCCC.
- UNFCCC Secretariat (2008) *Compilation and Analysis of Available Information on Ways and Means to Enhance Equitable Regional and Subregional Distribution of Projects Under the Clean Development Mechanism*. Bonn: UNFCCC.
- VCS (Voluntary Carbon Standard) (2008) *Guidance for Agriculture, Forestry and Other Land Use Projects*. New York: Russell Mittermeier / Conservation International.
- Wara, M. (2008) Measuring the Clean Development Mechanism's Performance and Potential. *UCLA Law Review* 55: 1759-1803.
- Wara, M., and Victor, D. (2008) *A Realistic Policy on International Carbon Offsets, PSED Working Paper #74*. Stanford: Program on Energy and Sustainable Development, Stanford University.

5. BIOMASS ENERGY USAGE IN DEVELOPING COUNTRIES: AN OVERVIEW OF THE DOMESTIC SECTOR

By Mulugeta Adamu

Consultant

Contact: mage@ethionet.et

5.1. ABSTRACT

Biomass is a vital energy source for over 2.5 billion people. It provides 14% of the world's primary energy and 30-90% of the primary energy supply in the developing world. Nearly 70-90% of the primary energy supply in Africa is derived from biomass sources. Of the biomass energy supply in Africa, some 90% is used in households with extremely wasteful traditional cookstoves that typically attain barely 5-15% efficiency. The low level of biomass fuel conversion efficiency is a leading cause of indoor pollution and respiratory diseases. It also generates needlessly large quantities of GHGs. In view of addressing these adverse impacts, many developing countries have initiated programmes for improvement of domestic cooking fuels and conversion efficiency. Such programmes have, in many countries, resulted in impressive improvements of cookstove efficiency, up to 30-40% in some cases. Improved biomass fuels, such as biogas and – more recently – producer gas, have been deployed in appropriately designed stoves. Several million stoves have been disseminated in Ethiopia and Kenya alone. But compared with the magnitude of biomass energy used in the household sector of the developing world, the overall effect of these efforts has not yet proved significant. Substantial improvement in fuel savings and reduction of indoor pollution at national, sub-regional and regional levels can be achieved by pursuing favourable policies, financial and legal instruments, and strategies for sustainable aggressive development and dissemination of improved biomass technologies.

5.2. INTRODUCTION

Biomass energy used in many developing countries is a vital but often ignored energy source. Biomass, which meets 14% of global energy needs, is predominantly used in households in the most wasteful fashion. A considerable amount of biomass energy is wasted due to extensive use of highly inefficient cookstoves. The wasteful usage of biomass presents another, related problem: that of creating indoor pollution and needless emissions of greenhouse gases (GHGs).

This situation, adverse as it is, also creates immense opportunities for improvement. The purpose of this paper is to highlight some of the opportunities open to us for improvement of domestic biomass usage. In the paper, no specific country or region is exclusively focused on. Common issues of domestic biomass usage are discussed and the concerns, as well as the opportunities, for improvement are highlighted. Examples are drawn particularly from the experiences of three countries, namely Ethiopia, Kenya and Sri Lanka.

Finally, the legal framework, policy options and financial instruments required to enhance improved and modern biomass technologies and to foster sustainable biomass supply are highlighted.

5.3. OVERVIEW OF DOMESTIC BIOMASS ENERGY CONSUMPTION

Biomass is the basic source of energy for a large segment of society in many developing countries. Biomass is predominantly used for cooking in households. Globally, more than 2.5 billion people use traditional biomass energy.

The absolute number of people relying globally on biomass energy between 2004-2030 will increase from 2.53 billion to 2.73 billion. In the same period, a marked increase of 25% in the number of people relying on biomass is expected to take place in sub-Saharan Africa. In Asia (excluding China, India and Indonesia), the increase will be 15%.

Table 5-1: People using traditional biomass (millions)

Region/country	2004	2015	2030	Change (2004-2030)
Sub-Saharan Africa	575	627	720	145
North Africa	4	5	5	1
India	740	777	782	42
China	480	453	394	-86
Indonesia	256	171	180	-76
Rest of Asia	489	521	561	72
Brazil	23	26	27	4
Rest of Latin America	60	60	56	-4
Total	2,528	2,640	2727	199

Source: IEA (2006) and FAO (2008)

5.3.1. DOMESTIC ENERGY REQUIREMENTS

A variety of applications such as cooking, baking, lighting and space heating, are among the most common domestic uses of biomass. Biomass is used in a multitude of forms. Charcoal,

woody biomass, twigs, leaves, agricultural residues and animal manure are the most common forms. Biomass in the form of biogas—and, in some cases, in the form of producer gas and alcohol (ethanol)—is used for cooking in households. Biomass utilization technologies range from direct combustion in simple three-stone stoves to the use of highly efficient metal charcoal stoves and biogas stoves. More recently, stoves known as “third-generation stoves” using the principle of natural draft gasification have been developed. In these kinds of stoves, the main fuel is “producer gas”, obtained by gasification.

Gasification is the process of converting solid fuels, such as wood, agricultural residues and coal into a combustible gas. A biomass gasifier consists primarily of a reactor or container into which fuel is fed along with a limited (less than stoichiometric amount required for complete combustion) supply of air. Heat for gasification is generated through partial combustion of the feed material. The resulting chemical breakdown of the fuel and internal reactions result in a combustible gas usually called “producer gas”. The heating value of this gas is in the range of 4-6 MJ/Nm³, or about 10-15 % of the heating value of natural gas. Producer gas is a mixture of the combustible gases hydrogen (H₂), carbon monoxide (CO), and methane (CH₄) and the incombustible gases carbon dioxide (CO₂) and nitrogen (N₂); the actual gas composition may vary considerably depending on fuel type and gasifier design (Bhattacharia and Leon 2005).

In gasifier stoves, at the start a small amount of air is introduced through the biomass to produce charcoal and combustible gas (the wood is pyrolysed). Secondary air is introduced above the fuel to combust the producer gas which provides energy for cooking. These stoves attain a combustion efficiency of 30-40% (Bhattacharia and Leon 2005).

The intensity of biomass energy usage for domestic cooking varies with cooking habits, the climate and, more importantly, with the ease of biomass collection. Because of the latter reason, marked differences in domestic utilization of biomass between urban and rural areas are observed (Table 5-2).

Table 5-2: Per capita total wood consumption (fuelwood and wood for charcoal) for energy (households and small scale industries) purpose in Eastern and Central African countries (m³/person/year)

Country	Rural Sparse < 2000 inhabitants	Rural settlements > 2000 inhabitants	Rural general	Urban
Egypt	0.35	0.24	0	0.21
Somalia			0.66	0.53
Eritrea	0.90	0.74	0	0.59
Burundi	1.48	1.08	0	0.70
Kenya	0.78	1.03	0	0.83
Sudan			1.09	1.09
Uganda	0.86	1.36	0	1.70
Tanzania			1.33	1.76
Rwanda	0.5	1.0	0	1.86
D.R. Congo			1.17	1.97
Average	0.8	1	1.1	11.24

Source: (Drigo, 2007)

It is also evident (from Table 5-2) that per capita wood consumption is lower in countries of wood scarcity than in those where wood is easily accessible. For example, the per capita consumption in the urban centres of the Democratic Republic of Congo, where there is easy access to fuel wood, is more than three times higher than in Egypt, Somalia, Eritrea or Burundi.

5.3.2. TYPES AND FORMS OF DOMESTIC FUELS

Traditional forms of biomass fuel commonly used in households for cooking and lighting consist of:

- Woody biomass fuels such as: wood, bark, leaves, twigs, sawdust and timber waste.
- Agricultural residues such as: maize, wheat and cotton stalks, maize cobs, coffee husks, sugar cane bagasse, coconut shells, rice husks, ground nuts husks, and oil press waste.
- Cow dung and animal waste.

Domestic biomass fuels are often used in transformed and “modernized” forms such as: charcoal, briquettes, biogas and alcohol (ethanol).

5.3.3. COMMON BIOMASS ENERGY TECHNOLOGIES

Domestic biomass energy technologies may be classified into three broad categories (Karekezi *et al.* 2004).

1) TRADITIONAL BIOMASS TECHNOLOGIES (TBT)

Traditional Biomass Technologies consist essentially of traditional cookstoves—the rudimentary open-fire type of stoves used by most rural households in the developing world. These stoves are notoriously wasteful, with an efficiency level of 5-10%. Other drawbacks of traditional biomass stoves include the diffusion of heat during windy conditions, the difficulty of controlling the fire, users’ exposure to heat and smoke as well as fire hazards. In spite of this, traditional stoves are extensively used by rural people, partly because of lack of awareness of the existence and advantages of improved biomass energy technologies and partly due to lack of access to these technologies.

Traditional biomass stoves are low-cost and require no fuel processing or preparation. In traditional biomass stoves, a range of biomass fuels are used. The main fuel-types are woody biomass, leaves, twigs, agricultural residues, animal manure, biomass wastes, etc. Urban wastes, such as paper and plastics, are also used in substantial quantity in traditional stoves. In addition to being wasteful, the stoves generate a significant amount of indoor pollution and GHGs. Traditional biomass stoves are one of the significant causes of respiratory disease in rural parts of the developing world.

Figure 5-1: Traditional three-stone stove common in households in Bangui, CAR



Source: Drigo and Salbitano (2008)

2) IMPROVED BIOMASS TECHNOLOGY (IBTS)

Improved biomass technologies refer to an improved version of traditional biomass stoves. The improvement is essentially in the efficiency, although there are typically associated benefits from reduced indoor pollution and greenhouse gas emissions.

The Kenyan Ceramic Jiko (KCJ) and the Ethiopian Laketch are examples of IBTs. These stoves are charcoal stoves of similar design. Both stoves have successful dissemination rates, particularly in urban centres. The Kenyan Jiko is said to attain an efficiency level of 40% (Agbaje 2008) and the Ethiopian Laketch some 20%. These are very efficient stoves compared with the traditional stoves that attain barely an efficiency of 5-15%.

Figure 5-2: Laketch stove, Ethiopia



Source: Bess (1995)

A total of over 780,000 KCJs were disseminated by 1995 and more than half of all urban households in Kenya owned the KCJ: 20,000 new stoves were being sold every month (Abaje, 2008). More than 2 million Laketch stoves were disseminated in total (Tilahun and Tsgereda, 1996).

3) MODERN BIOMASS FUELS (MBFS)

The fuel is produced by the conversion of biomass to liquid and gaseous fuels such as ethanol, biogas and producer gas. The stoves for using modern biomass fuels are carefully designed and manufactured and are convenient to use. Modern biomass fuels attain a high-level conversion efficiency of 30-40%. MBFs enable a clean cooking environment by drastically reducing indoor pollution and the emission of GHGs.

Figure 5-3: Wood-gas cookstove developed by Reed and Larson

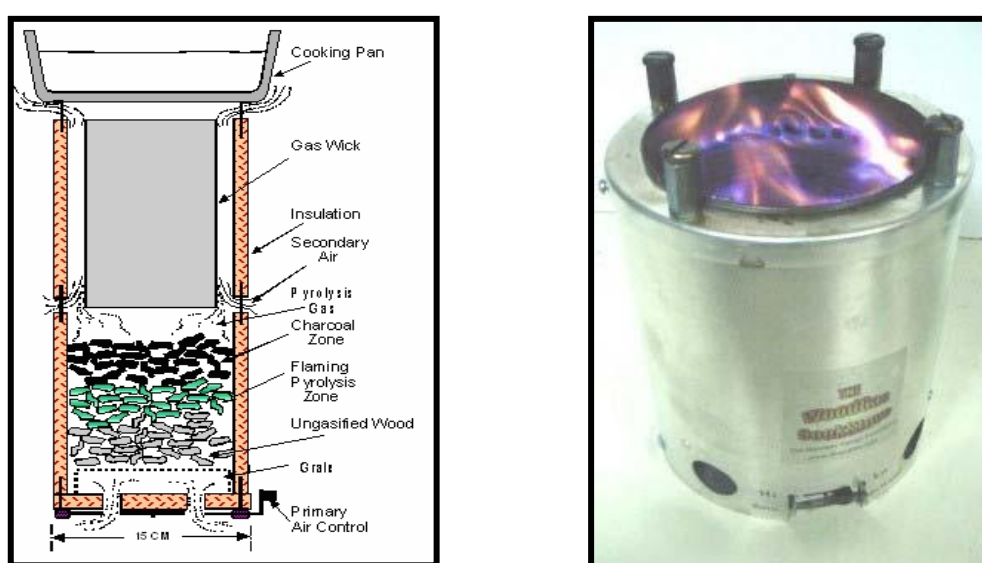

Source: Bhattacharya and Leon (2005)

The Wood-Gas Cookstove developed by Reed and Larson is an example of an MBF. The stove uses small wood chips and sticks for operation, produces very low CO₂ emissions, and is suitable for indoor cooking. The rate of gas production can be controlled by varying the primary air supply to the gasifier. The gasifier produces charcoal as a by-product (Bhattacharya and Leon 2005).

5.3.4. SOCIAL AND ENVIRONMENTAL ISSUES

In developing countries, the majority of rural people and the poorest section of urban dwellers collect biomass fuels freely. Collection of unpriced fuel wood often results in unsustainable mining of the biomass resource base around urban centres. Contraction of the biomass resource base makes the task of fuel collection increasingly difficult and time-consuming.

Among the biomass fuels, charcoal is a particularly useful cash commodity. The business of charcoal-making is a significant industry that engages a considerable number of rural people, mainly residing around urban centres.

In some developing countries, charcoal represents 2-9% of the total biomass supply (Table 5-4). Charcoal production is usually performed through illegal logging. Too often, precious natural forests that can take years to regenerate are lost for charcoal-making.

At the global level, unsustainable domestic biomass combustion generates a huge volume of GHG emissions. The estimated annual global release through domestic biomass burning is 1,495 Tg (tera grams) of carbon in the form of CO₂, 141 Tg of carbon in the form of CO, and 2.54 Tg of nitrogen in the form of NO (Ludwig *et al.* 2003). These are significant proportions of the annual global production of these environmentally important gases, representing 17% of total CO₂, 13% of total CO and 6% of total NO. However, this estimated CO₂ release is not necessarily a net emission, as it depends on the sustainability of the wood supply used. The use of agricultural residues and dung can be assumed to be 100% sustainable and therefore contributes no net CO₂ release to the atmosphere (Ludwig *et al.* 2003).

Another adverse effect of domestic use of biomass fuels is the acceleration of deforestation and soil degradation, due to the intensive use of biomass resources from sub-urban wood lots and communal forest land.

Use of agricultural residues and cow dung in large proportions for domestic energy purposes creates negative effects on agricultural productivity because these natural fertilizers and soil conditioners are carried away from the farms permanently and are never replaced or returned to the farm soil. As early as 1984, the World Bank warned that, in Ethiopia, the cost of total decrease in agricultural productivity due to using agricultural residues for energy purposes was equivalent to nearly 6% of GDP (World Bank 1984).

The positive aspect of domestic use of biomass energy is that it creates job opportunities for many poor communities. The employment potential of wood fuel and charcoal supply is larger than any other form of household fuels (Table 5-3). The job creating potential of improved biomass technologies is also considerable. Many people's lives have already been changed by engaging in the business of improved cookstoves production, distribution and retail selling.

Table 5-3: Estimated local employment potential of different household fuels per standard unit of energy consumed

Fuel type	Amount of fuel per TJ	Employment per TJ energy in workdays*
Kerosene ^ψ	29 kl	10
LPG	22 m ³	10–20
Coal ^β	43 tonnes	20–40
Electricity ^ϕ	228 MWh	80–110
Fuelwood ^θ	62 tonnes	100–170
Charcoal	33 tonnes	200–350

Source: UNDP/WB-ESMAP (1992), Drigo and Salbitano (2008)

* Employment covers growing, extraction, production, transmission, maintenance, distribution and sales, including reading of meters. It excludes employment generated outside the country for fuels that are imported in a semi-finished state.

^ψ This assumes that crude oil (for refining), kerosene and LPG are imported.

^β This varies according to the capital intensity of the mine, seam thickness, energy value of the coal and distance from demand centres.

^ϕ This varies according to production methods, ranging from hydro to traditional oil/coal-fired units

^θ This depends on the productivity of the site, efficiency of producers and distance from markets.

5.4. OPPORTUNITIES FOR IMPROVEMENT

5.4.1. EFFICIENCY

The current very low efficiency level of traditional stoves provides very high potential for fuel saving Table 5-5. Improvement in efficiency with respect to domestic biomass use should be considered at two levels.

The first is concerned with biomass fuel preparation and transformation efficiency. This is the efficiency associated with, for example, transforming raw biomass into charcoal or transforming cow dung (or other form of biomass) into biogas or other gaseous or liquid fuels.

In the process of transformation, often a significant amount of energy is wasted. For instance, in charcoal-making 1 kg of charcoal is obtained on average for every 3 kg of woody biomass (an efficiency of about 33%). The efficiency of traditional earth mound kilns used in many developing countries of Africa is even lower, about 18-20%. Ameliorating domestic biomass transformation efficiency is therefore one focus area of improvement for most developing countries that rely heavily on biomass fuels, particularly charcoal.

Table 5-4: Charcoal uses and energy loss in charcoal-making

Region	Share* (%)	Production (Mtoe)	Loss ^ψ (Mtoe)
1995			
East Asia	5	5.6	10.8
South Asia	2	3.5	9.1
Latin America	9	6.4	6.8
Africa	3	6.8	20.3
Total	3	2017.3	2042
2010			
<i>East Asia</i>	7	7.8	14.0
<i>South Asia</i>	3	7.9	20.3
<i>Latin America</i>	9	7.0	7.5
<i>Africa</i>	6	19.1	53.0
<i>Total</i>	4	6086.4	6188.8
2020			
<i>East Asia</i>	8	9.2	15.9
<i>South Asia</i>	4	11.1	28.4
<i>Latin America</i>	9	7.2	7.7
<i>Africa</i>	8	30.8	81.3
<i>Total</i>	5	14251.1	14530.9

Source: IEA (1998); Karekzi et al. (2004)

*Share of charcoal in total biomass used

^ψEnergy loss in charcoal production

The second concern is the efficiency of cookstoves. Traditional biomass cookstoves that are predominantly used for cooking and baking in most households in Africa, Asia and Latin America are extremely wasteful.

The combustion efficiency of charcoal stoves is about 20-25%. As indicated above, the transformation efficiency of charcoal-making is 33%. The biomass-to-useful-energy ratio of

charcoal utilization therefore barely has an overall efficiency of 6-8%—and possibly less if the charcoal comes from a traditional earth mound, which has an even lower transformation efficiency. This depicts a tremendous wastage of biomass energy.

The opportunity to improve the efficiency of biomass cookstoves has been explored in many developing countries. Recent developments in the design of stoves have greatly improved the efficiency of utilization of biomass in the household sector. Stoves such as the ceramic Jiko (for charcoal) and the Maendleo / Upesi (for wood fuel) developed in Kenya (Karekezi *et al.* 2004), the 'Laketch' (charcoal) and 'Mirt' (fuel wood) stoves developed in Ethiopia (Walelign 2004) can easily attain an efficiency level of 25-30% or more. In Sri Lanka, a recently developed natural and forced draft gasified wood stove is reported to constantly attain an efficiency level of some 35% (Bhattacharia and Leon 2005).

Table 5-5: Potential energy savings in selected developing countries from improved cookstoves

	Rural Household Bio-energy use (MTOE)	Efficiency Improvements (%)	Energy savings (Mtoe)	Maximum fuel wood savings ¹⁷ (million tonnes)
China	198	20-30	40-59	180
India	168	20-35	34-59	178
Latin America	28	10-40	3-12	36
Africa	116	30-40	35-46	141

Source: (IEA, 2001 in Karekezi *et al.*, 2004)

The challenging aspect of improved biomass stove development is in reaching out to the wider population. Ideally, stoves should be disseminated without compromising quality and efficiency, so that the intended outcome of attaining countrywide cooking efficiency improvement, with significant fuel saving and associated benefits, can be achieved.

Modernizing biomass fuels is perhaps another necessary step to combat some of the adverse effects of the present use of biomass at low efficiency. The transformation from traditional to improved to modern biomass technologies will enhance efficient use of resources. Biomass fuels transformed into gaseous and liquid fuels can be used for cooking and lighting in the households, with improved efficiency that results in significant fuel saving.

5.4.2. SUSTAINABILITY

Substitution of domestic biomass energy for other, alternative sources is nearly impossible for the vast majority of users. Domestic biomass substitutes are either too expensive or are not available. The option most accessible to billions of people who are using domestic biomass is to make efforts at local, national and regional levels to use the relevant biomass resources in a sustainable way. Sustainability in this regard means either to use improved and modern biomass technologies or to utilize the resource base at a rate commensurate to the incremental growth rate of the biomass resource or to plant trees to compensate for the shortfall through integrated planning and management.

¹⁷ Using the conversion factor: 1 tonne of firewood = 0.33 TOE.

With respect to the sustainable supply of domestic biomass energy, there are two major interlinked concerns of sustainability.

The first concern relates to the actual fuel saving from the utilization of improved biomass technologies. It is always possible to attain a good efficiency level for improved biomass stoves at the laboratory and pilot testing/dissemination level. This is possible mainly due to strict quality control in manufacturing and utilization of the stoves in the laboratory and pilot testing situations. However, during mass production and wider application of the stoves, often the quality and standard of production are not maintained: important parameters can be compromised. The end result is that improved stoves, which are expected to make a significant saving do not actually bring about the anticipated macro-level fuel saving. Providing proper training to stove producers and maintaining strict quality and control standards is therefore an important step towards attaining sustainable results in fuel saving.

The Kenyan and Ethiopian experiences show that education of stove producers, retailers and—most importantly—end-users should be an integral part of any improved stove development programme. All of these parties have to be educated on how to maintain key parameters of stove production and utilization, such as insulation thickness, chimney height and thickness, height of pot rest, air-vent diameter, etc. in order to achieve better results. Education of women in particular is a necessary step to achieve better results, as women tend to be the principal users of cookstoves.

The second concern of sustainable domestic biomass energy supply is how to meet the energy demand of an ever-growing number of households without excessively mining the resource base and adversely affecting the environment.

It should be noted, however, that biomass energy utilization alone is not the single primary cause of the destruction of forest land: the unplanned use of resources and raw materials such as food, fodder and timber are also major contributing factors (Drigo and Salbitano 2008).

5.5. COOKSTOVES AND FUEL IMPROVEMENT PROGRAMMES OF SOME DEVELOPING COUNTRIES

5.5.1. COOKSTOVE IMPROVEMENT

Many developing countries have programmes of traditional biomass cookstove improvement. The experiences of three countries, Ethiopia, Kenya and Sri Lanka, are described below.

ETHIOPIA

Biomass is an important energy source in Ethiopia. Biomass energy represents about 94% of total energy consumption. About 89% of the biomass energy supply is used by households. Given the low level of efficiency attained by traditional biomass technology used in the Ethiopian households, improving domestic cooking efficiency has been given emphasis.

Cooking efficiency improvement has been carried out in Ethiopia by a number of state and non-governmental organizations. The primary responsibility for developing improved biomass technology has, however, been entrusted to the Ethiopian Rural Energy Development and Promotion Centre (EREDPC). The Centre has, since the 1970s, been engaged in the business of improving household cooking efficiency, resulting in three

improved cookstoves, namely: the “laketch” charcoal stove, the “Mirt” fuel wood stove for making injera (a large, flat bread (pancake) made of sour dough that forms the staple diet in Ethiopia), and the “Gonzie” multi-purpose wood stove used for baking, cooking and boiling.

The “Laketch” charcoal stove has an efficiency of 19-21% and a fuel saving of some 25% compared with traditional stoves. The stove is popular among urban dwellers and is used mostly for coffee making and cooking stew. To date, over 2 million stoves have been disseminated (Tilahun and Tsigereda 1996).

Figure 5-4: Mirt fuel wood stove

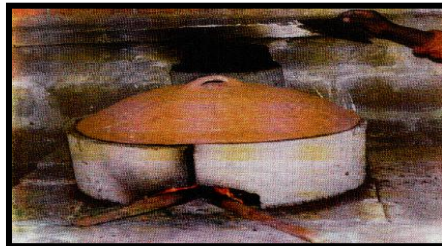

Source: Bess (1995)

The “Mirt” ‘injera’ stove has an efficiency of 16-21%. It has a fuel saving potential of 40-50% compared with traditional stoves. More than 1.2 million Mirt stoves have so far been disseminated.

The “Gonzie” multi-purpose stove attains an efficiency of 23%. It has fuel saving potential of 54% for baking and 42% for boiling and cooking compared with traditional practices.

KENYA

Biomass is an important energy source in Kenya. More than 70% of Kenyan energy supply is from biomass sources. In the rural areas, the contribution of biomass exceeds 90% of the energy supply. While fuel wood and other biomass types are used widely in the rural areas, charcoal is the dominant biomass fuel in urban areas.

Kenya is one of the few countries in the developing world that has successfully implemented a large-scale dissemination of improved wood fuel cookstoves. The Kenyan “Upesi” stove is the most popular fuel wood stove. The stove is reported to have cut fuel wood consumption by 50%. It burns fuel wood and agricultural residue (Practical Action Energy, No Date).

The success of the Kenyan biomass cookstove programme is partly attributable to the careful consideration during the design and manufacturing of the stoves of consumer requirements such as: stove affordability, durability and minimal shift from current cooking practices. Also, extensive training provided to local artisans that produce the stoves was one additional factor for the success. The effective marketing strategy in Kenya was to let the free market play the role of disseminator, without any intervention or provision of subsidies (Abaje 2008).

In 1980, Kenya started a charcoal stove improvement programme. This programme culminated in delivery of a charcoal stove known as the “Kenya Ceramic Jiko” (KCJ). The stove has a combustion efficiency of about 40%.

The KCJ is now produced in an organized fashion by mechanized and semi-mechanized producers. Close to 15,000 stoves roll out for sale every month (Karekezi *et al.* 2004).

Well over 800,000 KCJ stoves have been disseminated in total. During development and dissemination of KCJ the major problems encountered were quality control, standardization and monitoring of stove usage.

Figure 5-5: Kenya ceramic jiko

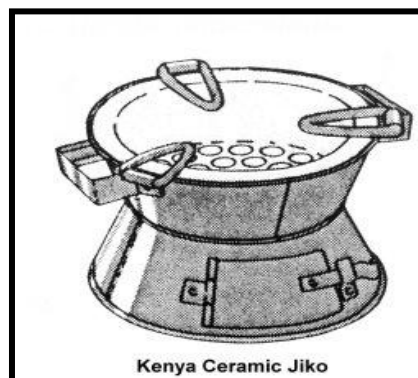

Source: Agbaje (2008)

SRI LANKA

In Sri Lanka, 51% of the energy supply is from biomass. Some 80% of the biomass energy is used in households. The conversion efficiency of biomass energy used in traditional household cookstoves, as in many other developing countries in the region, is exceedingly low (8-13%). Because of the crucial role of biomass energy in the national energy balance, a lot of effort has been expended to develop improved cookstoves. Both the government and NGOs have been involved in the development of cookstoves.

The most commonly used traditional cookstoves in Sri Lanka are the three-stone stove, the semi-enclosed stove, and single and two-spot clay stoves. Development efforts have resulted in the design of a number of improved cookstoves Table 5-6.

Table 5-6: Fuel efficiency of different types of cookstoves used in Sri Lanka

Type of stove	Efficiency (%)	Fuel type
Traditional cookstoves		
Three stone	8.0	Fuel wood, Agri-residue
Single and two pot mud stove	13.0	Fuel wood, Agri-residue
Improved cookstoves		
Anagi stove 1 & 2	18.0	Fuel wood
Sarvodaya two pot cookstove	22.0	Fuel wood
CISIR's Single pot stove	24.0	Fuel wood
IDB stove	20.0	Fuel Wood
NERD stove	27.0	Fuel Wood
Charcoal cookstove		
Ceylon charcoal cookstove	30	Charcoal

Source: (Biomass - Energy Toolbox, No Date)

The development of improved cookstoves in Sri Lanka has resulted in progressive improvements in efficiency. From among the improved cookstoves, however, the "Anagi-2" is said to be the most successful product, popular among users. About half a million Anagi-2 cookstoves have been sold and more than 400 potters and installers are trained in the construction and installation of Anagi-2

cookstoves. The future production rate is estimated to be about 120,000 units/year (Biomass - Energy Toolbox, No Date).

The most impressive design of improved cookstove in Sri Lanka, and launched recently, is, however, the NERD or “Lanka Shakthi” wood stove, developed by the National Energy Research and Development Centre of Sri Lanka (NERD Centre). The design is a wood gas (wood gasified) stove. The stove operates solely on firewood. The stove gasifies the wood and generates a combustible gas, enabling the stove to compete with modern gas stoves and thereby permitting a lower grade fuel (wood) to compete with a modern fuel. Other positive aspects of the stove include the reduction of firewood consumption, improvement of the kitchen environment and reduction of health hazards. The stove attains an efficiency level of 27%. This efficiency level represents a fuel saving of 70%. This would represent a huge resource saving at the national level if wider-scale dissemination and utilization of the stove can be achieved. To date, the stove has not yet been disseminated at a larger scale (Biomass – Energy Toolbox, No Date).

5.5.2. FUEL MODERNIZATION (BIOGAS PROGRAMMES)

The improvement of biomass utilization is not achieved from the cooking efficiency improvement side alone. Improvement can also be achieved from the modernization and transformation of the fuel itself. Modernization in this context means transformation of solid biomass fuels to gaseous or liquid fuels. One of the most practical transformations of biomass fuels into such so-called ‘modern’ fuels is the conversion into biogas.

Biogas can be used for cooking, using simple gas burners. Biogas can also be burnt in small mantle lamps to provide light. Biogas digesters also generate slurry which can be used as organic fertilizer. Commonly used biogas digesters are the floating drum and fixed dome types. The capacity of family-type digesters ranges from 4m³ to 10m³.

The transformation of agricultural residues and animal manure to biogas is an important conversion that has a far reaching consequence apart from the modernization of domestic biomass use. When the slurry from the digesters is returned back to farm land, biogas represents a modernization of domestic biomass use without any adverse effect on soil fertility.

Biogas programmes are underway in many developing countries in Africa, Asia and Latin America. Several million biogas digesters have been constructed and put to use. The most successful biogas programme conducted is perhaps the Chinese biogas development programme. In China, more than 25 million biogas digesters have been constructed and put to use. In India, some 5 million biogas digesters are in use.

In Africa a recently launched initiative, “Biogas for Better Life”, has a massive development programme of biogas dissemination. The target of the Initiative is to provide 2 million households with biogas digesters by 2020. The programme is anticipated to benefit 10 million Africans and create jobs for 100,000 people (Biogas for Better Life, No Date).

5.6. POLICY AND LEGAL ISSUES

Given the enormity of biomass energy usage by many developing countries, biomass will continue to be the major source of energy for the foreseeable future. Sustaining the supply, improving utilization and modernizing biomass energy will be important actions in the coming years.

The key issues, therefore, in domestic biomass use are: how to improve domestic biomass technologies in order to address all the negative effects of utilization; and how to achieve

sustainability of domestic biomass fuel supply. Growing biomass fuels to meet the ever-growing demand competes with food production for land and water. The need for clear policies and regulatory and legal frameworks to address these conflicting issues is evident.

Conducive policy and legal frameworks, in addition to resolving the conflict between food and energy production, will create favourable conditions for attracting investment in sustainable energy supply.

Sustainable supply of biomass fuels to both urban and rural consumers would theoretically require the plantation of new wood lots at the rate biomass fuels are consumed. Sustainable supply of biomass fuels is however more complex than this. A host of issues all require clear legal definition and regulatory guidance—such as the land requirement for planting wood lots; the responsible institutions for establishing and maintaining wood lots (for both privately- and communally-owned wood lots); the rights and responsibilities for harvesting, selling or distributing the biomass; the policy of using marginal land and which species can be grown).

Among the biomass fuels, charcoal production requires particular policy and legal consideration. With respect to charcoal making, an important intervention that must be sought is how to legitimize charcoal makers. Legalizing charcoal producers is anticipated to encourage them to abandon illegal logging of natural forest and produce charcoal in a sustainable fashion—for example by sourcing the wood from commercial plantations and using efficient kilns.

5.7. FINANCIAL INSTRUMENTS

The present use of biomass in most developing countries, particularly in Africa, is performed predominantly using traditional biomass technologies (TBT). This is a wasteful and unsustainable use of the resource. In addition, TBT generate considerable quantities of indoor pollution and needlessly emit GHGs. Improved biomass technology (IBT) and modern biomass technology (MBT) effectively address the problems of TBT. Utilization of IBT and MBT, in addition to ensuring sustainable utilization of the resource, can reduce significantly indoor pollution and the emission of GHGs.

To enhance utilization of improved and modern biomass energy technologies and foster sustainable biomass energy supply and utilization, a robust, sustainable financing mechanism is required. Development and dissemination of improved biomass technology at wider scale that can bring about real change in “improvement”, “modernization” and “efficiency” of biomass utilization for domestic application requires significant capital outlays.

The private sector can be attracted to undertake the promotion of improved biomass technology through appropriate policy and legal instruments. The private sector in this context constitutes all private individuals, women’s associations and producers’ unions who undertake activities such as:

- Development of fuelwood lots
- Development, production and dissemination of IBTs
- Development, production and dissemination of MBTs

The private sector can be supported by various policy measures. For instance, those involved in fuelwood development can be supported by the provision of free marginal land for fuelwood development. Those involved in the development, production and dissemination of Improved and modern biomass technologies (IBT & MBT) can be supported by provision of credit facilities, training and production space and production equipment. A number of options have to be considered to provide for the necessary financing required for enhancing IBT and MBT.

One of the possible options is to consider financing the enhancement of biomass fuels improvement and better technologies development endeavors through cross-subsidies between various energy sectors. For example, the petroleum and electricity sector can subsidize the modernization and efficient use of domestic biomass fuels efforts.

The other option is to consider financial revenue from carbon finance such as the CDM. Larger-scale enhancement of Improved and Modern biomass technologies (IBT & MBT) considerably reduces the needless emission of GHGs by promoting efficient and sustainable use of biomass energy in the household sector. An integrated project of fuel wood development with promotion of IBT and MBT will considerably reduce GHG and would in many circumstances qualify for revenue from the CDM.

5.8. CONCLUSION & RECOMMENDATIONS

Biomass is an important energy source that serves about 40% of the world population. For the majority of these energy users, the shift from biomass to other energy sources is practically unachievable. Biomass as it is used now, with wasteful traditional stoves and unpriced and unregulated harvesting of forest is unsustainable. The current mode of biomass utilization generates huge quantities of indoor pollution and GHGs.

Adverse effects of biomass utilization can be reversed through integrated planning and management that enhances:

- Utilization of Improved and modern biomass technology
- Regulated and sustainable utilization of resources

In order to foster sustainable utilization of biomass energy and improved biomass technologies, favourable financial, legal and policy instruments have to be devised.

Biomass is a major source of energy for many developing countries. Countries that rely on biomass fuels for a major portion of their energy consumption can no longer continue with the current trend of using the resource unsustainably. These countries need to take aggressive action to improve biomass energy technologies and to modernize the biomass energy source itself. In short, they have to work towards achieving sustainable supply and use of biomass energy.

Countries have to devise favourable legal and policy instruments to promote enhanced application of improved and modern biomass technologies.

In addition, these countries have to formulate suitable means of financing endeavours to ensure sustainable supply of biomass fuels and improvement of the production / usage of technologies. They have to exploit financial instruments at their disposal, such as sectoral cross-subsidy financing and revenue from the CDM.

5.9. REFERENCES

- Agbaje, T. (2008) Development and Dissemination of Improved Cookstoves for Energy Efficient Cooking. In *Developing World, the case of Kenya, Universitas 21 International Conference on Energy Technologies and Policy, 7th-10th September, 2008*, Birmingham, University of Nottingham, UK.
- Bess, M. (1995) *Status & Work Plan Report (1994-1995) of Cooking Efficiency Improvement and New Fuels Marketing Project*. Addis Ababa: Energy for Sustainable Development.
- Bhattacharya, S. C. and Augustus Leon, M. (2005) *Prospects for Biomass Gasifiers for Cooking Applications in Asia, Energy Field Study*. Thailand: Asian Institute of Technology.

- Biogas for Better Life, an African Initiative (No Date) Website (accessed 20 July 2009): <http://www.biogasafrica.org>
- Biomass – Energy Toolbox (No Date) The way forward for the use of wood and agricultural waste, for energy production in SE Asia, EU-funded project. Website (accessed 20 July 2009): <http://www.nri.org/projects/biomass/homepage.htm>
- Drigo, R. (2007) Wood-energy supply/demand scenarios in the context of poverty mapping, A WISDOM case study in Southeast Asia for the years 2000 and 2015. *Environment and Natural Resources Working Paper*. Rome: FAO.
- Drigo, R. and Salbitano, F. (2008) *WISDOM (Wood fuels Integrated Supply/Demand Overview Mapping) for Cities: Analysis of Wood Energy and Urbanization Using WISDOM Methodology*. Rome: FAO.
- FAO (2008) Forests and energy: Key issues. *FAO Forestry Paper 154*. Rome: FAO.
- IEA (International Energy Agency) (1998) *World Energy Outlook, 1998*. Paris: IEA.
- IEA (International Energy Agency) (2006) *World Energy Outlook 2006*. Paris: IEA.
- Karekezi, S.,Lata,K.,Coelho,S.T. (2004) Traditional Biomass Energy, Improving its use and Moving to Modern Energy Use. *International Conference for Renewable Energies, 2004*, Bonn.
- Ludwig, J., Marufu, L.T., Huber, B., Andreae, M.O., Helas, G. (2003) Domestic combustion of biomass fuels in developing countries: A major source of atmospheric pollutants. *Journal of Atmospheric Chemistry* 44: 23-37
- Practical Action. (No Date) Energy booklet - The Upesi stove for households in Kenya. Website (accessed 20 July 2009): <http://www.practicalaction.org/docs/energy/EnergyBooklet3.pdf>
- Tilahun, A., Tsigereda, A. (1996) *Impact of Improved Household Energy End-Use Devices: Household Energy Efficiency Improvement and Conservation Project*. Addis Ababa: Ethiopian Rural Energy Development and Promotion Center.
- UNDP/WB-ESMAP. (1992) *Philippines: Defining an Energy Strategy for the Household Sector*. Vol. I: Main Report. Manila: ESMAP and the Philippines Office of Energy Affairs.
- Walelign, G.T. (2004) *The Two Most Successful Cookstoves Technologies in Households of Ethiopia*. SESAM Graduate 2004.
- World Bank (1984) *Ethiopia: Issues and Options in the Energy Sector*. Washington DC: World Bank.

6. CHARCOAL PRODUCTION: OPPORTUNITIES AND BARRIERS FOR IMPROVING EFFICIENCY AND SUSTAINABILITY

By Yisehak Seboka

Consultant

Contact: yseboka@yahoo.com

6.1. ABSTRACT

Charcoal constitutes the primary urban fuel in Africa, and is a major source of income and environmental degradation in rural areas. With a lack of alternatives, demand for biomass in Africa is expected to double over the next ten years. Methods of charcoal production in Africa are in urgent need of upgrading. During the traditional process of carbonisation, only around 35% of the wood carbon is fixed in charcoal, while the rest is released into the atmosphere as smoke and non-condensable gases (CO_2 , CO , CH_4 , etc.). Because most of the energy of the fuelwood is lost in the production process, charcoal users ultimately use much more fuelwood than direct fuelwood users. This chapter reviews existing technologies for charcoal production as well as challenges and barriers to sustainable charcoal production. As key steps, it suggests legal recognition of charcoal production to draw producers out of the informal sector as well as improved land tenure systems. Such reforms would help reveal charcoal's real economic value and facilitate the adoption of new charcoal technologies.

6.2. INTRODUCTION

Biomass (wood, charcoal, agricultural residues, dung, etc.) is widely used as a source of energy in developing countries. Biomass energy is gradually penetrating the modern energy markets of industrialized countries as a clean and locally-available source of energy. Meanwhile, in developing countries, biomass fuels remain the dominant source of energy for over 2 billion people. The demand for biomass as a fuel in Africa will double during the next ten years (AfDB 2005).

In global terms, wood fuels represent approximately 7% of the world's total primary energy consumption. Most wood fuel use (76%) takes place in developing countries. Biomass use in the developing world is dominated by 20 countries, led by China, India, Brazil and Indonesia.

Charcoal constitutes the primary urban fuel in most developing countries, and is a major source of income and environmental degradation in rural areas. The production, transport and combustion of charcoal constitutes a critical energy and economic activity in the economies of many developing nations. Globally, approximately 40 million tonnes of charcoal are produced annually (FAO 1994).

Africa alone consumes about half of the world's charcoal production. In Asia, the pattern of charcoal consumption varies from extensive use as a domestic fuel (for example, in both urban and rural Thailand) to large-scale industrial fuel for the steel industry in the Philippines and Malaysia. In Latin America, charcoal is not a major household fuel, but is a notable source of energy for the steel industry in Brazil, Bolivia and Paraguay. Brazil is the leading producer of charcoal in the world, responsible for 39% of the world's production. Charcoal use as household fuel in Brazil is small, not higher than 9% for any income group, and generally 1% of total household fuel use (Behrens 1986).

Governments are generally trying to limit charcoal use, facilitate other alternatives, introduce fast-growing soft timber species to substitute for hard timber and promote other options such as natural gas, LPG, kerosene and electric stoves. In recent years, however, the increasing oil price has tended to undermine the switch to fossil fuels and electricity.

Charcoal is considered to be a separate fuel (distinct from wood fuel) since trace gases are emitted during its production and emissions from burning charcoal differ from those of wood. The carbonisation process used in converting wood to charcoal is generally inefficient, and volatiles including CO₂, CO, CH₄ and non-methane hydrocarbons (NMHC)—estimated at 60% by weight of the original wood—are emitted (Barnes *et al.* 2001).

6.3. CHARCOAL PRODUCTION

Charcoal is the solid residue remaining when wood species, agro-industrial wastes and other forms of biomass are carbonised or burned under controlled conditions in a confined space such as a kiln.

6.3.1. BIOMASS INPUTS TO CHARCOAL PRODUCTION

To enhance the supply of charcoal, it is important not to limit the choice of input (raw material) only to the commonly-used wood species such as *Acacia*. Other options, including the sustainable exploitation of other (short-rotation) tree species such as *Eucalyptus* as well as various types of plantation and industrial (or process) residues, should be assessed and evaluated.

Charcoal can be made from virtually any organic material, including wood, straw, coconut husks and shells, rice husks, cotton stalks, coffee husks, castor husks, bagasse, saw dust, bones, and others. Among woods, usually the hardwood species are preferred for charcoal-making (e.g. *Acacia*, mangrove, oak, beech, birch, hard maple, hickory and prosopis). Some fast-growing trees, such as

bamboo, also make excellent charcoal. Some of the biomass-types (tree species and agro-industrial wastes) used for quality charcoal or charcoal briquette-making are described in Table 6-1 below.

Table 6-1: Comparison of properties of biomass and biomass waste most commonly used for charcoal and charcoal briquetting

Charcoal Type	Suitability for Charcoal Production	Availability of Biomass	Cost	Calorific Value (Kcal per kg)
Acacia	Any carbonisation technology can be used	* Availability reduced in most countries. * Long period to mature. For example, <i>Acacia nilotica</i> takes 15 years to mature for charcoal in Sudan	Expensive	7,900
Eucalyptus	Any carbonisation technology can be used	* Available in abundance in many countries * Matures in 4-5 years	Relatively inexpensive	6,100
Prosopis juliflora	Any carbonisation technology can be used	* In African countries, such as Ethiopia, Kenya and Sudan, it is an invasive exotic tree	Inexpensive	7,150
Bamboo	Brick kiln, metal kiln or retort	* Abundant in Latin America, Asia (China and India) and Africa. (More than 1 million ha is available in Ethiopia). In many African countries it is neglected and not utilised at all	Inexpensive	6,920
Cotton stalk (briquette)	Metal kiln or retort	* Can be freely collected since it is generally burned on-site	Freely collected	5,300
Coffee husk (briquette)	Improved pit kiln or retort	* Can be freely collected since it is generally dumped in rivers.	Freely collected	5,100
Sawdust	Improved pit kiln or retort	* Can be freely collected since it is generally burned on-site.	Freely collected	4,980

Source: Seboka and Mequanint (2006), FAO (1993)

Where crop residues have little alternative use, these residues can be converted to charcoal. However, unlike woody biomass, agricultural residues such as cotton stalk, or process residues such as sawdust and coffee husk, cannot be carbonised using earth mounds or pit kilns. Due to their physical characteristics (shape, size and bulk density), such biomass materials tend to flare up and hence appropriate charring units need to be employed.

6.3.2. CHARCOAL-MAKING PROCESS

Charcoal-making differs widely between countries and can be based on a wide variety of techniques, some being well adjusted to their context, others less so (Girard 1992). Charcoal-making is the transformation of biomass through the process of pyrolysis. The process takes place in four main stages governed by the temperature required in each stage (Gerald 1986).

First stage – drying: is an endothermic reaction that takes place at a temperature range of 110°C-200°C. Air-dry wood contains 12-15% of adsorbed water; after the first stage all the water is removed. This stage requires heat input, which is provided by burning a fraction of the biomass that would otherwise have been converted into charcoal. The result of this stage is drying of the biomass to be carbonised (Kristofferson *et al.* 1984).

Second stage – of the pyrolysis process is an endothermic reaction (170-300°C) known as the “pre-carbonisation” stage. During this stage, some pyrolytic liquids such as methanol and acetic acid, and a small amount of non-condensable gases such as carbon monoxide and carbon dioxide, are produced.

Third stage – carbonisation: an exothermic reaction (250-300°C) takes place. In this stage, the bulk of the light tars and pyrolytic acids produced in the pyrolysis process are released from the biomass.

In the fourth and final stage, the temperature exceeds 300°C. During this stage, the biomass is transformed into charcoal, characterised by an increase in the fixed carbon content of the charcoal. The charcoal does, however, still contain appreciable amounts of tarry residue, together with the ash of the original biomass.

The ash content of the charcoal is about 3-5%; the tarry residue may amount to about 30% by weight and the balance (approximately 65-70%) is fixed carbon. Further heating increases the fixed carbon content by driving off and decomposing more of the tars. The maximum operating temperature is about 500°C. At this temperature, the fixed carbon content is approximately 85% and volatile content is 10%.

Good commercial charcoal should have a fixed carbon content of approximately 75%. Very high-quality charcoal, containing more than 80% carbon, tends to be used for industrial purposes (FAO 1987).

There is a negative linear relationship between methane emissions and the gravimetric yield (i.e. charcoal produced/tonne of wood). Methane emissions can be reduced by enhancing the carbonisation gravimetric yield. On average during the pyrolysis process, 39 kgCH₄/tonne of charcoal are produced. Generally speaking, 1000 g (1 kg) of dry wood produces the output shown in Figure 6-1 below.

Figure 6-1: Output from the transformation of 1 kg dry wood into charcoal

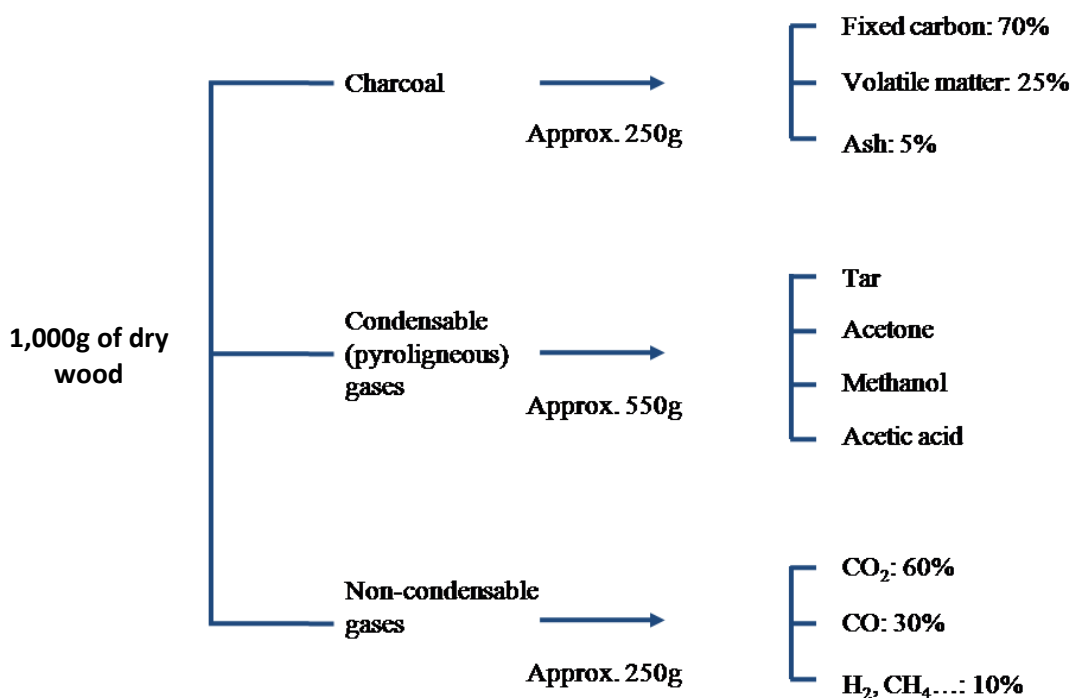

6.3.3. THE EFFICIENCY OF THE CHARCOAL PRODUCTION PROCESS

The major factors that influence the efficiency of charcoal production are:

- Moisture content of the biomass (drier is better)
- Type of kiln
- Size of the kiln (larger is better)
- Type of biomass
- Stacking of the biomass (denser is better)
- Skill and experience of the charcoalers
- Climatic conditions
- Temperature, oxygen supply and pressure

Weight-based conversion efficiency (yield) is a percentage rate expressing the ratio between the weight of the charcoal output and the weight of the air-dry wood input. For instance, the typical yield of a brick kiln (at 15 % moisture content) is about 30%.

The energy efficiency of carbonisation can be obtained by dividing the average lower heating value of the charcoal output by the average lower heating value of the biomass input at a given moisture content. The typical energy efficiency of a brick kiln (at 15% moisture content) is 65%.

6.4. CHARCOAL PRODUCTION TECHNOLOGIES

Figure 6-2: Types of charcoal kiln

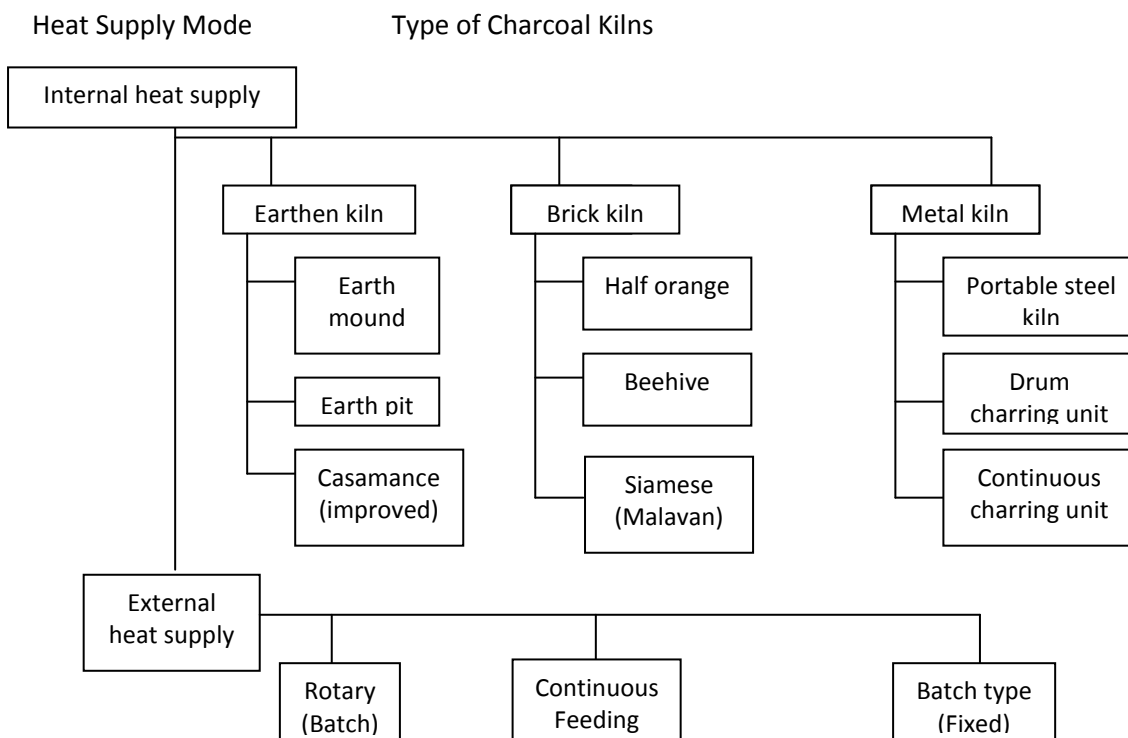

Methods of charcoal production in developing countries, and especially in Africa, are in urgent need of upgrading. The current inefficient charcoal production methods used in most of the developing world are polluting and destructive of forests. During the traditional process of carbonisation, only around 35% of the wood carbon is fixed in the charcoal, while the rest is released into the atmosphere as smoke and non-condensable gases (CO₂, CO, CH₄, etc.).

Worldwide, various types of charcoal-making technologies are employed: some use sophisticated designs and some are simple, both in their design and operation.

6.4.1. KILN (BATCH) METHOD

Kiln-types and production methods are detailed in Foley's classic *Charcoal Making in Developing Countries* (1986). Charcoal kilns generate the necessary heat for carbonisation by using the heat of combustion from part of the input material (the biomass).

Internally-heated charcoal kilns are the most common form of charcoal kiln. It is estimated that 10-20% of the wood (by weight) is sacrificed for energy-generation purposes; a further 60% (by weight) is lost through the conversion to gases and their release into the atmosphere from these kilns. The result is that only 20-30% of the original biomass is actually turned into charcoal.

Externally-heated reactors allow oxygen to be completely excluded, and thus provide better quality charcoal on a larger scale. They do, however, require the use of an external fuel source (biomass / gas), which may be provided from the 'producer gas' once pyrolysis is initiated.

Charcoal kilns may be **stationary** – traditional kilns (earth mound or pit kilns); brick or masonry kilns; and kilns made from a combination of brick and metal – or may be **mobile**, made from sheet metals.

EARTH KILNS

EARTH MOUND (TRADITIONAL)

This type of kiln dominates charcoal production in Africa. The biomass is gathered and cut to size, and placed on a ground kiln. The mound or pile of biomass on the ground is covered with earth. The earth forms the necessary gas-tight insulating barrier behind which carbonisation can take place without leakage of air, which would allow the charcoal to burn away to ash. The kiln is fired and the biomass heats up and begins to pyrolyze. The kiln is mostly sealed, although a few air pockets are initially left open for steam and smoke to escape. As the kiln emissions change colour, the charcoaler may seal some air pockets. When the production process has ended, the kilns are opened or dug up and the charcoal is removed. The conversion efficiency of this type of kiln is typically about 10-15%.

EARTH MOUND (TRADITIONAL)		
	Advantages	Disadvantages
	<ul style="list-style-type: none"> • Requires no special equipment • Very flexible with regard to capacity (volume to be carbonised) • Makes it possible to use large logs without cutting or splitting • No capital outlay 	<ul style="list-style-type: none"> • Very poor control of carbonisation, hence considerable losses • Charcoal contaminated with soil when the heap is broken open • Efficiency generally low • Small-size agro-industrial wastes are difficult to carbonise in this manner

IMPROVED EARTH MOUND (CASAMANCE)¹⁸

The Casamance is an improved version of earth mound kiln. The improvement derives from better stacking of the wood on a circular platform around a central post inserted for stability and covered with earth and leaf material. This has holes at the base and introduces a “chimney” structure to the charcoal-making process.

This type of kiln has a typical efficiency of about 20%. Casamance kiln operation is very similar to that of the earth mound kiln. The only exception is that the operation of the Casamance kiln is guided and controlled by the smoke coming out of the chimney.

This kiln is generally regarded as a successful technology for increased efficiency. However, its penetration has been very limited (Feinstein *et al.* 1991).

IMPROVED EARTH MOUND (CASAMANCE)		
	Advantages	Disadvantages
	<ul style="list-style-type: none">• Relatively inexpensive• Gas circulation is good• Takes less time to achieve carbonisation compared with the traditional earth mound• A considerable amount of tar can be collected from the chimney	<ul style="list-style-type: none">• Demands barrels for the construction of the chimney• Charcoal is contaminated with soil when the heap is broken open• Small-size agro-industrial wastes such as coffee husks, saw dust, cotton stalks etc. are difficult to carbonise in this manner

PIT KILNS

TRADITIONAL PIT KILN



Pit kilns are preferred where the soil is well drained, deep and easy to excavate. The earth is excavated to the required depth, width and length. Wood is heaped into the trench, making provision for air passages. The wood is loaded horizontally into the pit and covered with grass, leaves and then earth to ensure that it is airtight and that it has sufficient thermal insulation. The pit is then left for about 4 days to allow cooling to take place and the complete process takes about 7 days. Charcoal yields from such pits are low (10-15%).

¹⁸ The name ‘Casamance’ comes from the Casamance region of southern Senegal.

IMPROVED PIT KILN

The improved pit kiln has iron sheets to cover the pit to prevent contamination of the charcoal with earth and a chimney and air vents to improve air flow through the kiln. Charcoal yields from this type of improved pit kiln can reach 25%.

IMPROVED PIT KILN		
	Advantages	Disadvantages
	<ul style="list-style-type: none"> Capital investment is minimal (only axe, shovel and matches are required) 	<ul style="list-style-type: none"> Very difficult to control the circulation of the gases in the pit Re-absorption of pyroligneous acid through rain falling on the pit

BRICK KILNS

There are many designs of brick kilns in use throughout the world and most are capable of producing relatively good yields. Types of brick kiln include: the Brazilian beehive kiln, the Argentine half-orange kiln, the European Schwartz kiln and the Missouri kiln. The shape and structure of the kiln varies, and there are vertical kiln and horizontal kilns: the vertical kiln is more popular. In China, one brick kiln with a charcoal production capacity of 900kg costs US\$500-800. The processing period is 2 weeks.

Most of the charcoal used commercially in Brazil is produced in brick kilns with a weight-based conversion efficiency of wood to charcoal (yield) of 33% (FAO 2003). The energy efficiency of a half-orange brick kiln using biomass stock (15% moisture content) is about 65%, indicating that 35% of the energy contained in the feedstock is lost during the carbonisation process.

BRICK KILN		
	Advantages	Disadvantages
	<ul style="list-style-type: none"> Offers higher yields than mound or pit kilns Produces better quality charcoal Can be built in any village with basic masonry skills. Has a lifespan of 6-10 years 	<ul style="list-style-type: none"> Immobile (lack of transportability) Relatively high cost Longer production cycle (on average, 15 days).

METAL KILNS

Metal kilns are constructed from sheet metals or barrels flattened and joint together then turned round to produce a large diameter barrel open on the top and the bottom. Metal kilns can easily be fabricated at metal workshops. Among the well known types are: TPI, Mark V and drum charring units.

METAL KILNS	
Advantages	Disadvantages
<ul style="list-style-type: none"> • Air supply and gas flows during the carbonisation process. • Less supervision of the process is required compared with the constant attendance necessary with pits and mounds. • Average conversion efficiencies of 25% can be consistently achieved. Pits and mounds give erratic, often lower, yields. • All of the charcoal produced in the process can be recovered. With traditional methods (pits and mounds), some of the charcoal produced is lost in the ground and that which is recovered is often contaminated with earth and stones. • Metal kilns, if designed to shed water from the cover, can be operated in areas of high rainfall, providing the site has adequate drainage. Traditional methods of charcoal production are difficult to operate in wet conditions. • With greater control of the process, a wider variety of raw materials can be carbonised. These can include softwood, scrub wood, cotton stalk and others. • Can be transported to where the feedstock is collected and therefore saves on feedstock transport costs. • The total production cycle using metal kilns takes 2-3 days. 	<ul style="list-style-type: none"> • The raw material and product are in a sealed container, offering greater control of The disadvantages of using metal kilns compared with the traditional earth pit or mound method are: • High capital costs • For ease of packing and maximum efficiency, some care is needed in the preparation of the raw material. The biomass must be cut and / or split to size to fit into the kiln. • Transportable metal kilns can prove difficult to move in hilly terrain. • The lifespan of metal kilns is only 2-3 years.

TPI METAL KILN

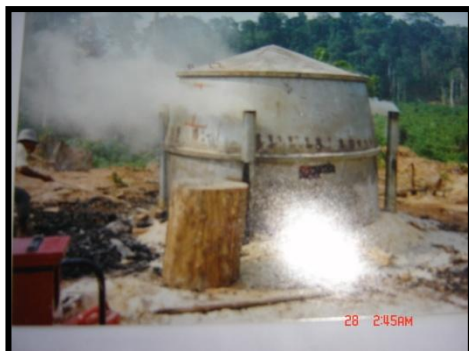

- Capacity 7m³
- Has 4 chimneys and 8 air inlet-outlet channels positioned under the kiln's bottom section
- 2 cylindrical sections (upper and lower) and a conical steel cover

MARK V METAL KILN



- One of the best-known metal kilns
- Has a main body of 2 cylinders joined with a slightly conical lid and top
- The lid has a hole in the centre which is capped except during ignition

DRUM CHARRING UNITS



- Drum charring units are metal charcoal kilns made from 200 litre oil drums
- Fast-burning raw materials such as agro-industrial wastes (coffee husks, cotton stalks, bamboo waste, saw dust, etc.) can be successfully carbonised using this method
- The conversion efficiency is, on average, 25%

6.4.2. RETORT (CONTINUOUS) METHOD – SEMI-INDUSTRIAL AND INDUSTRIAL

A kiln carbonises biomass in a closed container and releases gas and vapour to the atmosphere. In contrast, a retort carbonizes biomass, condenses the gas and vapour, and collects the gas or liquid tar in a container. The retort represents one of the most efficient means of producing good-quality charcoal.

These are two types: vertical and horizontal. The vertical retort is made of two closed vertical metal cylinders one inside another. The biomass material is put in the inner cylinder; while heating, the smoke circles in the space between the two cylinders. This type of kiln has a high efficiency in charcoal production, a shorter processing period and a higher output rate.

Retorts are externally heated and controlling the charring temperature within a very narrow range is possible, unlike the traditional kilns described above. The uniformity of charring temperature within the retort is achieved by rotating the charring unit or by movement of the input material. A fraction of the biomass is used as a fuel to heat the retort.

Retorts are expensive and rare in the context of charcoal production in developing countries (except in limited situations where commercial charcoal production from agricultural residues is practised).

RETORT (CONTINUOUS) METHOD	
Advantages	Disadvantages
<ul style="list-style-type: none"> • High yield of charcoal • Charcoal quality can be controlled • The by-products can be controlled 	<ul style="list-style-type: none"> • The unit is capital-intensive (US\$100,000) • The unit requires an external energy source • The unit is not portable and requires a concentrated supply of raw material

SEMI-INDUSTRIAL RETORTS

Table 6-2: Semi-industrial retort-types (CCS and ICPS)

Continuous Carbonisation System for Biomass (CCS)	<ul style="list-style-type: none"> • A large tower (height 7m, length 3. m) in which the biomass falls in through the chimney and is dried and pre-carbonised while falling through the hot volatiles towards a carbonisation zone in the middle of the tower (an area with limited air supply). • The CCS is a viable carbonisation system for light biomass such as coffee hulls, rice husks, shredded biomass and wood chips. • Cost approximately 20,000 Euros
Improved Charcoal Production System (ICPS) (Adam Retort)	<ul style="list-style-type: none"> • A low-cost retort kiln to make charcoal from wood or biomass developed in East Africa and India by a German designer (Chris Adam). • Works as a batch system. • The Adam retort is a low-cost semi-industrial retort kiln. The wood chamber is filled with wood and the charcoal emptied after about 30 hours • High economy and better efficiency of approximately 35%. • This new and innovative retort kiln saves up to half of the wood needed to make the same amount of charcoal relative to the earth mound kiln. Methane emissions are 75% less than for the earth mound kiln.

Advantages of Improved Charcoal Production System (Adam Retort):

- Recycling and clean combustion of the pyrolysis gas during the pre-carbonisation (second phase) of operation results in low emissions of carbon monoxide during charcoal production. The effective carbonisation of the biomass takes only about 10 hours compared with 4-5 days for traditional kilns.
- Low investment costs (about 300 Euros) and simple construction.
- About 700-800kg of wet biomass or about 600kg of dry biomass can be converted into up to 250kg of charcoal per batch.
- Only waste and residual biomass needs to be burnt (50kg) in a separate fire-box to dry and heat the wood and initiate the carbonisation process during the first phase. In the case of traditional kilns, waste biomass can be added to the kiln to start ignition but not to supply the energy to the kiln.

INDUSTRIAL RETORT TECHNOLOGY

This is the method used in Europe, USA and other developed countries to manufacture charcoal on an industrial scale. These industrial plants are, unfortunately, impracticable in the rural areas of developing countries because the investment and maintenance costs of the process are too high. This method utilizes indirect (external) heating of the biomass by passing hot gas through it. The hot gas is obtained by burning a fuel, which can be wood, oil or gas.

A retort has separate combustion chambers. Thus for starting the pyrolysis process, the burner (combustion chamber) has to be ignited separately. Once the carbonisation goods are sufficiently heated to deliver burnable flue gases, no external fuel is needed. A typical industrial retort works with throughputs of up to 200 tonnes/hour (Jargstorf 2004).

Advantages of industrial retort technology:

- The yield of charcoal from the wood is higher (by 40-50%)
- Carbonisation is more rapid.
- Charcoal can be made from raw materials such as agricultural residues and process wastes (cotton stalk, coffee husk, saw dust and others) that cannot be processed by traditional methods
- Industrial chemicals and heat energy can be recovered from the smoke given off during carbonisation
- By recovering by-products from the smoke there is less pollution of the environment

Table 6-3: Summary of charcoal production methods

	Yield %	Carbonisation duration	Investment Costs	Capital intensity	Labour intensity
Earth pit kilns	10-15	1-5 weeks	low	Low	High
Brick and steel kilns	25-30	1-12 days	US\$1,000 - US\$7,000	Medium / high	Medium
Large-scale plants / retorts	30-40	20-30 hours continuously	US\$7,000 - US\$7m	High	Low

Source: ITDG (1992)

6.6. BRIQUETTING

Briquetting or densification is used to improve the characteristics of materials for transport and for use as an energy source. Briquetting improves the density, burning time, and other energy characteristics of the biomass. Raw materials that are typically briquetted include bagasse, sawdust, loose crop residues, urban solid wastes, industrial wastes, charcoal fines and others. The charcoal is first produced and then it is briquetted; depending on the material, the pressure and the speed of densification, additional binders such as starch molasses and clay soil may be needed to “glue” the material together.

Briquettes are used for outdoor cooking in developed countries. The largest briquette manufacturer in the United States uses only waste products for its wood supply. Wood shavings, sawdust and bark from pallet manufacturers, flooring manufacturers and lumber mills are converted from piles of waste into useful briquettes. It is estimated that the US can produce 150,000 tonnes of charcoal briquettes valued at US\$100-200 million per year (ex-production facility) and save US\$1.75 million that would otherwise be used for disposal of the biomass waste.

Developing countries have considerable biomass materials that could be used for energy but which are currently wasted. In Kenya, research by the Chardust Briquetting Company has identified baggase, coffee husks, sawdust, coconut husks and lump wood waste as materials that can be made into good-quality charcoal.

Alongside improving charcoal kiln efficiency and promoting improved forestry practices, countries including China, India, Vietnam, the Netherlands, Denmark, South Africa and Kenya are developing new, high-quality charcoal briquettes from fast-growing trees, agro-industrial wastes, bamboo and other resources as an alternative to hardwood charcoal.

Bamboo-based charcoal producers in Asia have developed techniques to also collect the vinegar and tar from charcoal production. Biomass vinegar is a liquid produced during the pyrogenic decomposition of biomass, consisting of water, organic acids, phenols, ketones, alcohols and other complex compounds. Purified woody vinegar can be used for food fumigation (notably for ham and sausages), preventing insect attack and giving the food a fresh taste. It can also be used in bathrooms for deodorisation.

Some of the major briquetting technologies are described below.

PISTON PRESS

Piston press briquetting technology is the dominant technology in India, Brazil and Africa. While such presses are locally made in India and Brazil, the African machines are mostly imported.

- The material is punched into a die by a ram using high pressure.
- Solid briquettes (without holes through the centre of the briquette) are produced.
- Flywheel drive machines typically produce between 300-500kg of briquettes per hour while hydraulic machines can produce up to 200kg/hour (Russell, 2006).

SCREW PRESS

The material is compacted continuously by a screw through a die heated from outside, normally electrically. Briquettes of higher quality and with holes at the centre are produced. The hole is simply a by-product of the screw thread passing through the centre: however, it also increases the surface area of the briquette and aids efficient combustion.

Briquettes produced by this method tend to be strong. They have very good burning characteristics and do not fall apart during combustion. The raw material needs to be relatively dry (12% moisture content maximum) and particle size should be uniform for the screw press to be used.

Screw presses are much simpler than other high-pressure briquetting equipment and cost less than piston presses. The problem with a screw feeder is that its form and pitch is designed to suit a particular particle size, so if this alters the screw is liable to jam. Also the screw form is susceptible to wear, especially when using materials with high silica content, necessitating regular maintenance.

Due to the highly abrasive nature of charcoal, the commonly-used briquetting technologies, such as the piston or screw press, are not suitable for briquetting of charcoal. They are typically used for briquetting of non-carbonised biomass such as wood chips, saw dust and other raw biomass after they have been ground to powder.

ROLL PRESS

Roll presses are used in the developed world for briquetting charcoal produced from a variety of different types of biomass. In a roll press, a mixture of charcoal and binders are fed to the tangential pockets of two roller presses to produce pillow-shaped briquettes. The smooth production of

briquettes using this technology requires high-quality rollers with smooth surfaces on which the briquettes are shaped.

Currently, available roll presses have minimum production capacities in the range of 1-4 tonnes/hour. The 1 tonne/hr capacity press with controlled feeding device costs about \$320,000. Roller-type charcoal briquetting machines with a capacity of 1.5 tonne/hr costing \$19,000 can be found in India.

AGGLOMERATOR

The most successful briquetting processes used in many developing countries are the agglomerated charcoal briquette and the honeycomb charcoal briquette. The charcoal is powdered, 20%-25% clay or other binders are added, the constituents are mixed together, and the mix is then either agglomerated or put into a honeycomb dye.

Agglomeration technology involves size enlargement of a nucleus/balls of charcoal formed within a rotating cylinder. Agglomerated charcoal briquettes are produced using a motor-driven agglomerator, the typical nominal capacity of which is 25-50kg/hour.

Agglomerated charcoal briquettes are round and typically have diameters between 20-30 mm. This technology can be used well for household cooking as well as fuelling industrial furnaces which use fuel-shapes similar to pellets.

Pellets are small in size (about 1cm in diameter and 2-4 cm in length) while briquettes are of relatively large size (typically 5-6 cm in diameter and 30-40 cm in length). Charcoal briquettes are used to substitute “raw” charcoal. Because of their small and uniform size, pellets are particularly suitable for fuelling industrial furnaces (Bhattacharya 2003).

BEEHIVE / HONEYCOMB BRIQUETTING MACHINE

The honeycomb briquetting machine is cost-effective and uses simple mechanical and electrical parts to produce uniform, highly-packed briquettes in a uniform mode (about one briquette per minute), suitable for small and medium sizes. Consumers use small-size beehive briquettes for short-time cooking or boiling in order not to waste the briquette; large-size beehive briquettes are used for long-time cooking. Typically, 2 briquettes of 500g each are produced at a time.



Honeycomb briquettes have excellent burning qualities as they burn from the inside out through small holes so the energy release is gradual and uniform, giving a blue flame.



The principal drawback of this is that it requires a special stove (beehive stove), which is readily available in Vietnam, China and Thailand, but is less well-known in Africa.

6.7. THE CHARCOAL BRIQUETTING PROCESS

After collection, the wood or agro-industrial waste is dried before it is converted to charcoal in a charring kiln. Charring produces a good yield of 20-30%. Using retorts, it is possible to obtain 30% charcoal and 25-30% condensable gases, leaving only 25-30% waste.

The carbonised biomass is ground and then mixed with a small quantity of cheap, locally-available binder such as starch, Arabic gum, molasses, clay and others (the binder is mixed with water and then mixed with the charcoal powder). Finally, the mixture (powdered charcoal + binder mixture) is extruded into briquettes. To remove the moisture from the freshly produced charcoal briquettes, it is necessary to dry them in the sun for at least a week (depending on the climate). After drying, the briquettes are packed and sent to market.

Figure 6-3: Schematic flow diagram of agglomerated urban solid waste charcoal production

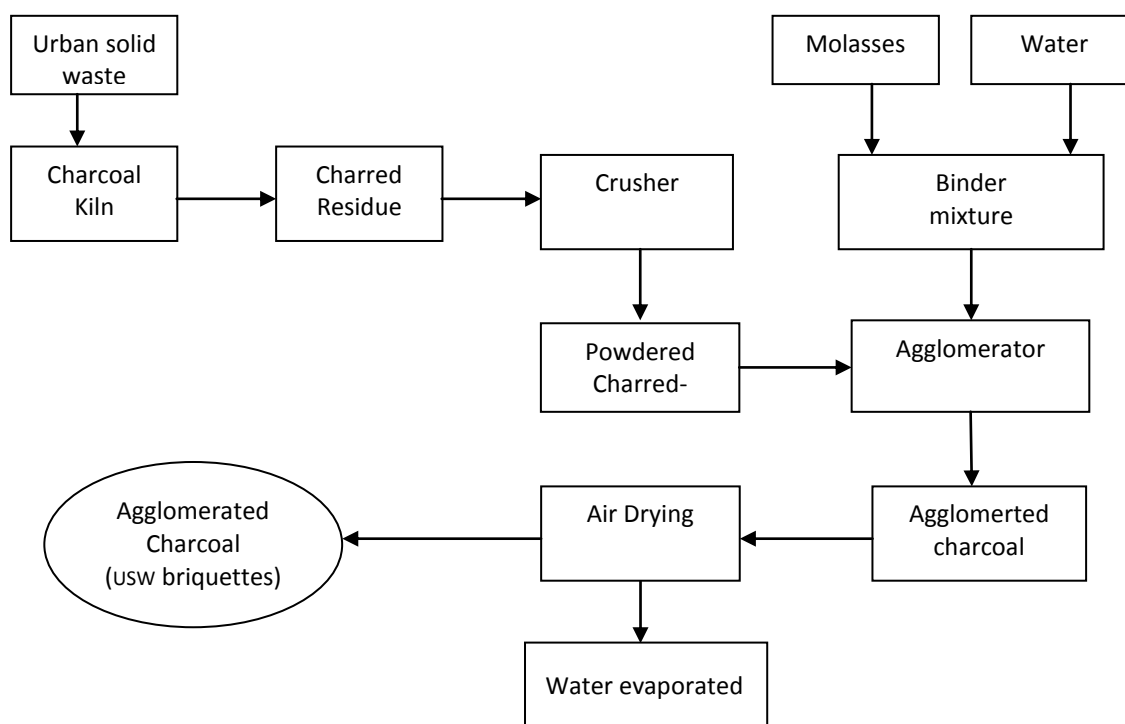

Some countries in Africa, notably South Africa, Egypt and Kenya, are actively producing charcoal briquettes from agro-industrial wastes.

A good example of acceptable charcoal briquette production in East Africa is the Kahawa Coffee Husk Charcoal Company in Kenya. These charcoal briquettes are made from charred coffee husk, with rice starch used as a binding agent. This charcoal briquette has a number of advantages over the commonly-used wood charcoal: it burns longer, it is less smoky, it produces no dangerous sparks, the cost is relatively low, it has consistent (composition) quality, and it can be conveniently packaged for transport and storage.

6.8. ADVANTAGES & DISADVANTAGES OF CHARCOAL COMPARED WITH FUELWOOD AND OTHER BIOMASS ENERGY SOURCES

6.8.1. ADVANTAGES

- **User Convenience:**
 - Charcoal can be an excellent domestic fuel. Charcoal is cleaner, easier to handle, less smoky, is sulphur-free and is better suited to towns and cities than other biomass fuels such as fuelwood.
 - It has excellent cooking properties: it burns evenly, for a long time, and can be easily extinguished and reheated. Even in developed countries, charcoal is valued for the flavours that it imparts to grilled food.
 - In some countries, notably Brazil, charcoal is used as an industrial fuel in steel, metallurgy and cement production. About 25.4 million m³ of charcoal are used as an industrial fuel in Brazil. In countries with extensive forests and a deficiency of coking coal (such as Brazil), the use of charcoal for iron smelting is profitable.
- **Weight reduction for long distance transportation:** One of the reasons for converting wood into charcoal is to reduce its weight with respect to its energy content and to increase its economic transportation distance. The resulting charred material not only burns longer and more steadily than whole wood, but it is much lighter (one-fifth to one-third of its original weight). By converting biomass into charcoal, one benefits from reducing the transportation cost per MJ.
- **Higher calorific value (energy content):** The calorific value of charcoal primarily depends on its quality, depending on the amount of water, volatiles and ash content. Freshly-made charcoal has zero water content, but it may rapidly gain moisture from the air during storage. Charcoal commonly used for domestic purposes has a net calorific value of 28 MJ/kg (Gerald, 1986), meaning that its net energy value is roughly twice as much as for air-dried fuelwood (16 MJ/kg). This large difference makes charcoal cheaper to transport over a longer distance compared to fuelwood on a comparative energy basis.
- **Charcoal takes less room** (is denser) and can be stored in containers for transport and sale more easily than fuelwood.
- **Charcoal is not liable to damage by insects and fungi:** unlike fuelwood, charcoal has the attraction that it can be stored for long periods without degradation and insect attack.
- **Charcoal does not need regular supervision during cooking,** unlike wood.

6.8.2. DISADVANTAGES

The major disadvantages of charcoal, at least currently, in most developing countries is that it is made by methods that are of low efficiency and that waste more than 50% of the heating value contained in the original wood. Because most of the energy of the fuelwood is lost in the production process, charcoal users ultimately use much more fuelwood than direct fuelwood users. But, if more efficient charcoal production processes and more efficient charcoal end-uses are adopted, then the net effect is in favour of charcoal.

6.9. THE USES OF CHARCOAL

6.9.1. AS DOMESTIC FUEL

Charcoal is a major source of energy in developing countries, particularly as a household cooking fuel. For domestic purposes, charcoal is used in cooking and heating. Reasons include its affordability (low cost), the fact that it is easily traded in small quantities, its ease of use and handling (convenience), the fact that it is not easily damaged by rain or moisture, the good taste it imparts to food, the fact that it burns with less smoke, and the fact that it requires only simple and cheap stoves for its use domestically.

Reasons favouring charcoal as the preferred household fuel of the urban poor rather than “modern” fuels:

- Much lower initial capital investment in the cooking stoves
- The stoves are relatively simple and easy to use
- Charcoal is often sold in neighbourhoods, making for easier accessibility
- It is perceived to be safer to use than gas or electric cookers

As users become more affluent, they typically switch from wood fuels to charcoal and then to petroleum fuels such as kerosene or LPG as these latter two fuels are clean, have higher heating value and can be used with efficient stoves. Charcoal’s position in the middle of the cooking ladder implies that, with economic growth, charcoal users will switch to more modern and efficient fuels, but that other biomass users, on the order of two billion people, may switch from other biomass to charcoal. Since charcoal users are typically urban-based, its use— particularly when urban growth is rapid—can place a severe strain on the locally-available woody biomass resource base.

Another reason for increasing charcoal demand can be increasing prices for electricity and kerosene, which may force households to move down the energy ladder instead of continuing to use modern fuels. Charcoal is typically the fuel of choice in this instance. As a recent example, following electricity price increases and a lifting of a government subsidy on kerosene in Ethiopia in 2008, widespread switching to charcoal was observed in Addis Ababa.

6.9.2. AS AN INDUSTRIAL FUEL

The advantages of charcoal depend on six significant properties which account for its continued use in industry. These are: low sulphur content, high ratio of carbon to ash, relatively few and unreactive inorganic impurities, stable pore structure with high surface area, good reduction ability and almost smokeless combustion.

Charcoal as an industrial fuel undergoes intricate treatment to increase its adsorption properties. Mostly activated charcoal is treated and is available in powdered, granular and pelletized form.

6.9.3. NON-ENERGY PURPOSES

Charcoal can also be used:

- For extraction of metals, particularly iron, from their ores. Large amounts of charcoal are used in copper and zinc production, as well as in the production of precious metals.
- Charcoal is used for ironing of clothes, food vending and tea drying. In some countries, charcoal is used for non-energy purposes such as water purification, for soil texture improvement and humidity control (bamboo charcoal).
- Manufacturing of incense sticks.

For industrial uses, better quality charcoal (with higher carbon content) is needed.

6.10. SUSTAINABLE CHARCOAL PRODUCTION & CONSUMPTION

The population, particularly the urban population, in Africa is growing, and so too is its demand for charcoal. The need for increased supplies of charcoal produced from improved-efficiency pyrolytic processes is, therefore, urgent. However, this is not enough.

A systems approach (tracking material flows from extraction through to disposal) is recommended to ensure sustainable material consumption at all biomass life-cycle stages (wood harvesting, pyrolysis, briquetting, charcoal use, ash disposal). The aim is to minimise material and energy losses at all stages. Wood (or some alternative form of biomass) should be obtained from a sustainably-grown biomass resource and should be harvested using efficient techniques to ensure minimum biomass waste is generated. The wood should then be converted into charcoal using improved-efficiency kilns, after which proper handling is needed during briquetting, packaging, storage and transportation to minimise waste. Finally, the charcoal should be consumed using improved cookstoves.

Forest services and energy commissions / agencies should give particular attention to charcoal and its sustainable production and use. Effective interventions might include (among others):

- The establishment of sustainable forest management programmes to avoid over-harvesting of species suitable for charcoal production.
- Providing charcoal-makers with a range of suitable technical methods from which to choose, rather than a single 'best' technical solution.
- The promotion of charcoal from residues and forest plantation timber, through pricing and appropriate policies.
- Adapting / improving the briquetting process. If the process is made more efficient, there will be less wastage of charcoal.

6.10.1. OPPORTUNITIES AND BARRIERS FOR IMPROVING THE EFFICIENCY & SUSTAINABILITY OF CHARCOAL PRODUCTION

BARRIERS

Some of the technical and non-technical barriers to be removed in the years to come are:

- New technologies are needed to make biomass fuel more cost-effective and competitive with other energy options. To overcome this obstacle of introducing improved charcoal production technologies:

- Awareness creation and training on how to use improved equipment.
- Financial support from the government or concerned authorities.
- Regulation of forests to prevent open-access depletion.
- New policies are needed for the development of biomass fuel markets:
 - Abolish restrictions on the fuelwood and charcoal trade.
 - Promote vertical and horizontal integration of fuelwood and charcoal markets to overcome current problems associated with isolated markets for these commodities.
 - Develop the notion of professional charcoalers and move away from individual and occasional charcoalers.
 - Provide technical and financial support to wood producers at sustainable levels (through management plans), potentially including exemptions from land taxes and promotional support to buy seedlings.
 - Provide technical and financial support to professional charcoalers, such as reduction of taxes and support to buy efficient carbonisation equipment.
- Legal and institutional barriers: lack of regulatory coordination, lack of data available at the regional level, plus lack of capacity of adequate staff.
- Lack of finance to purchase modern kilns: the costs of modern kilns are high. Low-income charcoal-makers should have access to a revolving fund or loans from banks to overcome their shortage of finance.

CHALLENGES AND BARRIERS TO SUSTAINABLE CHARCOAL PRODUCTION

GOVERNMENTS IGNORE CHARCOAL AS A MAIN SOURCE OF ENERGY AND LEAVE IT TO THE INFORMAL SECTOR

Many countries' national policies and energy-sector programmes tend to consider wood-based fuels (chiefly fuelwood and charcoal) a backward and ecologically risky energy source, and seek to discourage its use or mitigate its prevalence. Consequently, they call for replacing the so-called "traditional fuels" with "modern fuels". Uganda's short- and medium-term policy priorities (2002-2012), for example, are principally focused on promoting fossil fuels or other substitute energy sources.

Similar observations apply to the national energy policies of Sierra Leone and Chad, where political efforts centred on electrification absorb the majority of financial allocations to the energy sector.

In most developing countries, traditional energy sources are deliberately shunned and left to the informal sector, especially to women. Small-scale self-help approaches tend to predominate over strategic and concerted efforts. Most energy policies focused on modernisation do not even mention gender-related issues. Analysis of 22 African countries' energy policies and strategies revealed that only in two documents gender issues were mentioned: Tanzania and Zambia (AFREPREN & ENDA, 2006).

WEAK POLICY COHERENCE

Common goals can only be achieved by making sure that policies are not fragmented, that they do not overlap, and that they do not result in unnecessary or additional transaction costs. This calls for thorough inter-ministerial policy coordination.

However, policy coherence, consensus, and commitment in the wood-fuel sector suffer from insufficient open discussion of policy options. Additionally, the authority and jurisdiction of ministries, agencies and associations typically lack clarity with regard to traditional energy sources, with the result that some encroach on others' terrains.

The principal means of fostering policy coherence are a national energy policy and a strategy designed to implement it, with roles and responsibilities assigned clearly to the various institutions (institutional coherence). Additionally, policies at each level (national, regional and local) ought to be streamlined before actions are implemented (horizontal coherence), and coherent implementation from national level downwards must be guaranteed (vertical coherence).

LACK OF BASELINE INFORMATION FOR POLICY FORMULATION

Shaping charcoal policies presupposes reliable baseline information as a pre-condition for rational decisions. Obtaining precise data on the charcoal value chain would provide an excellent entry-point for shaping sound policy frameworks. Such data would offer an opportunity to the various stakeholders to add knowledge, innovation, capital and technology at each step or link in the value chain. On this basis, checks and balances may be introduced to assure more balanced development within and between the sectors, with a view to achieving the intended overarching goals (for example, achieving the Millennium Development Goals).

LIMITED WILL/GOVERNANCE CAPACITY TO REORGANIZE THE CHARCOAL PRODUCTION SECTOR

In many countries, the forest sector's contribution to the national economy is marginal (2-4%), due to the fact that production and use of wood-base fuels are informal and thus escape official statistics (e.g. Uganda: formal sector 11% against 89% in the informal sector (Sepp 2008)). The majority of charcoal producers work illegally since charcoal production is, in theory, banned in many countries.

Consequently, forest governance receives little attention and meagre budgetary allocations. As a consequence local branches of the forest service often display low human, technical and enforcement capacities. This problem is often exacerbated by half-hearted or arbitrary decentralisation of forest governance, which leaves local administrators poorly prepared for the challenge of promoting community involvement or investment by the private sector. Such institutional weaknesses lower the morale of local staff, and can serve to invite corruption. Corruption, coupled with unclear policy and legal frameworks, is seen as a major cause of unregulated, and often illegal, charcoal business.

CHARCOAL AS AN UNDER-PRICED ENERGY RESOURCE

Despite growing scarcity of wood, charcoal generally remains under-priced by more than 20-50% relative to its economic cost in most African countries (Sepp 2008). This is mainly caused by insecure land-tenure, which leaves many forest areas open to free and unregulated access and use. In consequence, market prices of wood-based fuels reflect only the opportunity cost of labour and capital required for production and transport. Undervaluation translates into wasteful forest management and tree growing. The following examples illustrate the consequences:

Investment costs for improved kilns (metal chimneys, etc.) do not pay off as long as wood remains a free resource. Despite training support, charcoal burners eventually abandon the improved technology. This is the principal reason why the improved and efficient Casamance kiln has been disseminated for 20 years throughout Africa without much success.

Tree growing approaches remain ineffective, as planting and maintenance costs must be taken into account when competing with open access resources. Significant subsidies (e.g. Madagascar: €200-

300/hectare) are necessary to provide sufficient incentive. This also holds true for any investments in natural forest management (Sepp, 2008).

Substitute fuels such as kerosene must be highly subsidised to be competitive, as is the case in a number of countries (e.g. Senegal, Chad). On the one hand, the need for substantial subsidies creates a long-term foreign exchange burden and tilts a country's trade balance. On the other hand, no subsidies can ever be high enough to benefit poor households—in consequence, only the wealthier segments of society benefit. Furthermore, state subsidies for substitute fuels send incorrect market signals, further discouraging investment in tree planting or forest management by communities or the private sector.

OPPORTUNITIES

It is considerably easier to disseminate charcoal on a large scale than fossil fuels, because there is a well developed market and expensive infrastructure such as refineries and processing plants is not needed. Charcoal production is a more distributed (locally-based) model of energy supply than fossil fuels. In developing countries, there is no developed market for fossil fuels, but charcoal is well distributed even in small villages.

Charcoal production can make use of locally-available waste resources. If undertaken appropriately, it is more environmentally sustainable and it reduces the need for imported fossil fuels.

6.11. ECONOMIC, SOCIAL AND ENVIRONMENTAL IMPACTS (POSITIVE & NEGATIVE) OF CHARCOAL MANUFACTURE

6.11.1. ECONOMIC IMPACTS

Charcoal is the affordable source of household energy in the developing world. Africa has the largest per capita charcoal use. Fuel choice decisions among urban households are strongly affected by income levels, although taste preferences and stove costs are also important.

EMPLOYMENT OPPORTUNITIES AND INCOME

Charcoal as a commercial fuel offers significant employment opportunities everywhere around the world. Job creation in charcoal involves relatively low investment costs. Studies carried out in Brazil show that biomass industries require an investment of between US\$15,000 and \$100,000 per job generated, compared with US\$800,000 per job in the petrochemical industry and over \$10 million per job for hydro power (Domac 2002).

Charcoal production is also labour-intensive. The human labour required for the production of biomass resources is about five times higher than that needed for the production of fossil fuels. An analysis from Brazil has shown that charcoal production contributes some 200,000 to 300,000 jobs to national employment. Although charcoal employment has an impact primarily in rural areas of developing countries, it is also important in cities and in developed countries. Estimated employment generation by fuel type is shown in Table 6-4.

Table 6-4: Estimated employment by fuel-type

Fuel Type	Amount of fuel per Terajoule (TJ)	Estimated Employment per TJ
Kerosene	29 kilolitre	10
LPG	22 tons	10-20
Coal	43 Tonnes	20-40
Electricity	228 MWh	80-110
Fuelwood	62 tonnes	110-170
Charcoal	33 tonnes	200-350

Source: Battari (1998)

EFFICIENCY IMPROVEMENT

The introduction of improved kilns and stoves has proven to be worthwhile in some countries. The maximum saving in biomass can best be achieved only by a combined use of improved charcoal-making kilns with the parallel use of improved stoves for cooking and end-uses for industry. Through the deployment of improved kilns and improved stoves, the demand for wood can effectively be cut to about half of the current baseline (that is, relative to the traditional kiln / traditional stove-scenario).

6.11.2. SOCIAL IMPACTS

Although improved-efficiency kilns and stoves are desirable to conserve resources and reduce emissions, it should be stressed that the technology transfer must be appropriate for the region and accompanied by training and education.

6.11.3. ENVIRONMENTAL IMPACTS

POSITIVE ENVIRONMENTAL IMPACTS OF CHARCOAL MANUFACTURE

Use of cleaner, more efficient cooking fuels in developing countries would save millions of lives and offer benefits for climate change and development. According to a 2005 study (Kammen & Lew 2005), charcoal can provide comparable health benefits of between 1.0-2.8 million avoided deaths relative to the use of fuelwood.

Charcoal burns more cleanly and produces less indoor pollution than wood. There are, therefore, indoor air quality benefits associated with the use of charcoal. At the same time, however, it has to be recognized that the inefficient production methods of charcoal production currently in use in much of the developing world are also highly polluting in a GHG context and are destructive of forests.

By creating the technological and policy tools for transitioning to higher-efficiency charcoal production technologies and sustainable harvesting, such as those used today in Brazil and Thailand, GHG emissions can be reduced by 45-66% (Sanders 2005). Nowadays, Brazil produces large amounts of charcoal from forest residues and forest plantations by using the "Improved Brazilian Brick Kiln" which can convert 2m³ of biomass to 1m³ of charcoal, implying a yield of 50%.

With a traditional and inefficient kiln, emissions are considerable but with modern and efficient kilns emissions can be significantly reduced. As an example, through the use of the Casamance kiln, pyrolytic and creosotic products can be condensed; without the chimney, these products would have been emitted into the air. Thus, efficient charcoal-making technologies realise a lower environmental impact than their traditional and inefficient counterparts.

Helping developing nations to make the transition to clean charcoal without drastically increasing pollution and destroying forests would be an excellent way to achieve several of the Millennium Development Goals, among them reducing child mortality, ensuring gender equity and ensuring environmental sustainability.

Intertwined in charcoal production and use are global environmental effects. Because much of the charcoal feedstock is not plantation wood, the unsustainable harvesting of biomass results in net CO₂ emissions. In addition to the production of charcoal, pyrolysis of biomass also produces incomplete combustibles, such as methane, which may have a higher overall global warming impact than CO₂. In fact, the main global warming impact of the charcoal cycle may result from the biomass pyrolysis and not the end-use of charcoal burning.

Emissions from charcoal can be reduced in both the production and consumption components of its life cycle. Emission reductions in charcoal production can be achieved by improving the efficiency of the kilns, and emission reductions in charcoal end-use can be achieved by disseminating improved (high-efficiency and low-emission) charcoal stoves, which reduce emissions by improving both combustion and heat transfer efficiency.

NEGATIVE ENVIRONMENTAL IMPACTS OF CHARCOAL PRODUCTION

The high population growth rate and low rate of switching to non-carboniferous household energy sources in the developing world imply that the rate of carbon dioxide release from biomass burning is likely to increase in the foreseeable future. This will further accelerate the build-up of atmospheric carbon dioxide, with consequential effects on global warming and climate change.

Table 6-5: Emission rates (g/kg dry matter) during charcoal production & use

	CO ₂	CO	CH ₄	NO _x
Fuelwood	1,500	70	4.5	1.0
Charcoal (making)	1,593	254	39	0.073
Charcoal (combustion)	2,740	230	8	3.9

Source: Siteo (2008)

6.12. CHARCOAL POLICY

Developing countries depend on charcoal as a major urban household energy source. Because of this, it is critical to assess and to develop long-range charcoal policies for African and other developing nations. The environmental and social impacts of charcoal production and consumption are extensive and intertwined, such that an integrated view is essential in policy making.

OFFICIAL RECOGNITION OF CHARCOAL PRODUCTION AND MARKETING

Licensing of charcoal production and trade to encourage its commercial production in a sustainable manner needs to be addressed. Energy policy for many developing countries tends to place more emphasis on commercial energy, denying biomass energy the comprehensive treatment it deserves. Where some policies exist, they tend to lack coherence. For instance, although energy policy in countries such as Ethiopia and Kenya favours the development and promotion of improved charcoal cookstoves and sustainable farm forestry for fuelwood, charcoal-making actually remains illegal in these countries. The ban does not stop charcoal production or trade, but, instead, has served to

drive the industry further into the informal sector, escaping public regulation and revenue collection, fuelling illegal payouts to officials along transit routes, damaging the wholesale and retail business of those unable to secure charcoal supplies, and most importantly, causing an inflationary spike in the price of charcoal nationwide.

National energy and technology policies need to be harmonised to allow for cross-border technology transfer and capacity building. Personnel exchange among collaborating institutional entities could be promoted through such schemes. The most efficient Casamance charcoal kiln (improved traditional earth mound) has been a great success in Senegal while the brick kiln is relatively more efficient in Brazil. These successful technologies could be disseminated elsewhere in other developing countries under appropriate institutional and policy frameworks.

PROMOTE INTRODUCTION OF EFFICIENT CHARCOAL KILNS IN CHARCOAL PRODUCTION

In most developing countries, charcoal production efficiency is very low, sometimes as low as 15%. Charcoal producers should be encouraged, and capacitated, to achieve higher conversion efficiencies using cheap and better charcoal-making technologies. Due to the open-access status of many natural forests, the unavailability of modern and efficient charcoal-making kilns, the high cost of improved kilns and other reasons, market pressures alone are unlikely to lead to efficiency opportunities being exploited.

PROMOTE EFFICIENT CHARCOAL STOVES

Policy should seek to promote the development of wood, alternative biomass and charcoal stoves that are more efficient and convenient to users and which produce minimal emissions.

PROMOTE THE USE OF FAST-MATURING TREES AND AGRICULTURAL WASTES

Reduce the GHG impacts of charcoal production by sourcing biomass feedstock from fast-growing species such as bamboo and eucalyptus, and from agri-residues such as from the coffee, tea and floriculture industries.

LAND TENURE POLICY

Without a more effective land and tree tenure policy in place, it is difficult to expect major changes towards forest management practices. A review of land and tree tenure arrangements is an important area of inquiry since biomass charcoal enhancement through the promotion of farm forestry and homestead tree-planting practices is a possible policy entry-point to which rural households have access.

6.13. CONCLUSIONS

The energy crisis in the developing world is growing ever more critical. Biomass energy supplies are becoming depleted. If biomass conversion technologies can be extensively introduced, the use of biomass for energy purposes could make a substantial contribution to sustainable rural and urban development. In the coming decades, most African households will remain dependent on biomass fuels since they have limited access to, or little disposable income for, modern energy services. In this context, improving the sustainability and efficiency of biomass energy generally—and charcoal production and usage specifically—is crucial.

6.14. REFERENCES

- AFREPREN & ENDA (2006). *Compendium of National Energy Policies and Strategies*. Abidjan: African Development Bank
- Bailis R., Ezzati M. and Kammen D.M. (2000). *Greenhouse Gas Implications of Household Energy Technology in Kenya*. Berkeley, CA: Renewable and Appropriate Energy Laboratory.
- Barnes D.F, Krutilla K. and Hyde W. (2001) *The Urban Household Energy Transition: Social & Environmental Impacts in the Developing World*. Washington, DC: World Bank.
- Behrens, A. (1986) Total energy consumption by Brazilian households. *Energy*, 11, p.607-611.
- Bhattacharya S.C. (2003) Biomass Energy and Densification: A Global Review with Emphasis on Developing Countries. São Paulo: Centro Nacional de Referência em Biomassa.
- Bhattarai, T.N. (1998) Charcoal and its Socio-Economic Importance in Asia. *Paper presented at the regional training workshop on charcoal production, Pontianak, Indonesia, 1998*.
- Desai, A. (1990) *Energy in Africa*. New Delhi: Wiley Eastern Limited.
- Domac, J. (2002) Bio-energy and job creation. *Unasylva* 53: 18-20.
- FAO (1985) *Industrial Charcoal Making, Forestry Paper 63*. Rome: FAO.
- FAO (1987) *Simple Technologies for Charcoal Making, Forestry Paper 41*. Rome: FAO
- FAO (1993) *Charcoal Production and Marketing in Gujarat*. Bangkok: Regional Wood Energy Development Programme in Asia.
- FAO (1994) *Forestry Products*. Rome, Italy.
- FAO (2003) FAOSTAT-Forestry Data. Rome: FAO. Website (accessed 20 July 2009): <http://apps.fao.org/page/collections?subset=forestry>.
- Feinstein, C and van der Plas R. (1991) *Improving Charcoaling Efficiency in the Traditional Rural Sector, Energy Series Paper No.38*. Washington, DC: World Bank.
- Foley, G. (1986) *Charcoal Making in Developing Countries*. London: Earthscan.
- ITDG (Intermediate Technology Development Group) (1992) *Boiling Point*
- Jargstorf, B. (2004) Renewable Energy and Development. *Renewable Energy in Ethiopia*. Exhibition jointly organized by GTZ and Ethiopian Rural Energy Development & Promotion Center (EREDPC). Addis Ababa, April 2004.
- Kammen D.M. & Lew D.J. (2007) *Review of Technologies for the Production and Use of Charcoal*. Berkeley, CA: Renewable and Appropriate Energy Laboratory.
- Kebede D. (2001) *Charcoal Production Efficiency Improvement and Supply enhancement Options*, Report submitted to Ethiopian Rural Energy Development & Promotion Centre. Addis Ababa, Ethiopia.
- Mugo F. and Ong C. (2006) *Lessons from Eastern Africa's Unsustainable Charcoal Trade*. Nairobi: World Agro-Forestry Centre.
- Openshaw. K.O. (1986) *Concepts and Methods for Collecting and Compiling Statistics on Biomass Used as Energy*. Rome: N.W. Statistical Office Workshop.
- Openshaw, K.O. (1997) *Urban Biomass Fuels: Production, Transportation and Trading Study (A Consolidated Report)*. Silver Spring, Maryland: Malawi Ministry of Energy and Mining.
- Russell A. (2006) Briquetting agricultural residues. *Boiling Point* 39.
- Sanders R. (2005) Study of energy and health in Africa focus spotlight on charcoal and forest management. *Science* 308.
- Seboka Y. and Mequanint N. (2006) *Laboratory Test Results on Charcoal and Charcoal Briquettes Made From Selected Trees and Agro-Industrial Wastes*. Report submitted to Ethiopian Rural Energy Development & Promotion Centre Addis Ababa, Ethiopia.
- Sepp S. (2008) Shaping Charcoal Policies: Context, Process and Instruments as Exemplified by Country Cases. *Charcoal Conference, 16-18 June 2008*, Eduardo Mondlane University, Mozambique.
- Shenxue J (2004) *Training Manual of Bamboo Charcoal for Producers and Consumers*. Nanjing China: Bamboo Engineering Research Centre.
- Sitoe A. (2008) Charcoal and carbon emissions. *Charcoal Conference, 16-18 June 2008*, Eduardo Mondlane University, Mozambique.
- Wenbiao Z. (2006) *Bamboo Charcoal and Vinegar Production Technologies and Utilisation*. Zhejiang, China: Zhejiang Forestry University.
- Woods, J., and Hal, D.O. (1994) Bio-energy for Development: Technical and Environmental Dimensions, *FAO Environment and Energy Paper No.13*. Rome: FAO.

7. CATALYSING BIO-ENERGY IN AFRICA: A REVIEW OF POLICY OPTIONS AND INSTRUMENTS

By Jeffrey Biggs

Faculty of Forestry, University of Toronto

Contact: Contact: biggsjef@gmail.com

7.1. ABSTRACT

This chapter examines the contexts and means whereby biomass energy production and usage may be catalyzed in Africa. It shows that prospects exist for basic bio-energy technologies of direct combustion of forest and agricultural products and residues as well as pyrolysis, gasification, anaerobic digestion, alcoholic fermentation and mechanical conversion of oil-seeds. Differing from other regions, in Africa concerns of energy delivery, industrial efficiency and sanitation will be the main drivers of bio-energy policy change. Yet any policy will need to be designed to overcome barriers that bio-energy development faces in Africa, particularly (though not limited to) opposition from vested interests associated with fossil fuels, up-front costs, supply chain complexity, competition for land and resources, inadequate demand, relatively rare suitable sites, low management capacity and a paucity of available investment and research funds. Policy options including financial incentives (FITs, green certificates, tender schemes, blending requirements and differential taxation), research and entrepreneurial development, power purchase liberalization and demonstration projects will all help to overcome these barriers, funded either through self-financing, the CDM, international donors or microcredit.

7.2. INTRODUCTION – CATALYZING BIOMASS ENERGY IN AFRICA

Biomass not only generates 11-15% of the world's heating and electrical energy, it is one of the world's fastest growing energy sources. Opinions are shifting away from bio-energy as the energy supply of the past, to that of the future. Some have projected that by 2050 bio-energy could supply up to 250 EJ/y, approximately 30% of global energy demand (Best and Christensen 2003). Key elements in this change are the perceived unique benefits for bio-energy relative to fossil fuel and other renewable energy (RE) resources, especially as they relate to the poor. These include:

- Existence in gaseous, liquid and solid states (unlike other RE);
- Wide availability (in principle, wherever food and fiber crops are grown or processed);
- Temporal flexibility of consumption (it is stored energy that can be provided without expensive storage devices such as batteries);
- Intrinsically rural (thereby contributing to new and sustainable rural livelihoods);
- Improving waste disposal (consuming existing agricultural, municipal, industrial and human wastes of biological origin);
- Ameliorating gender discrepancies (collection and consumption of traditional biomass resources is often the responsibility of women and girls);
- Potential for new, high value exports (as has begun to occur in the Brazilian bioethanol industry, providing a valuable source of foreign exchange);
- Providing opportunities for rural electrification with low infrastructure costs (and the host of multiplier benefits associated therewith);
- Promoting environmental sustainability (through greenhouse gas (GHG) emissions reductions/offsetting as well as site remediation, biodiversity and contaminant reduction benefits) (Amigun *et al* 2008; Bandyopadhyay *et al.* 2006; Best and Christensen 2003; DESA 2007; Ejigu 2008; Karkezi and Kithyoma 2006; Kartha *et al.* 2005).

As a result of its lagging economic performance and widespread rural poverty, Africa has been held up as potentially the primary beneficiary of the “new” bio-energy (Amigun *et al.* 2008).¹⁹ The role of bio-energy in meeting the Millennium Development Goals (MDGs) of poverty (MDG 1), education (MDG 2), gender (MDG 3), health (MDGs 4, 5, 6) and especially environment (7) has been identified as critical in the African context (Amigun *et al.*, 2008, UNDP, 2007).

However, significant concerns about the development of bio-energy exist. Bio-energy crops that displace food production can result in increased food prices, which can have a negative impact on the poor. For example, US bio-energy subsidies have resulted in as much as one-third of the US maize crop being directed towards ethanol production, which, when combined with similar efforts in Brazil and the EU, have been estimated to have contributed to 30% of the recent average increase in world cereal prices (Von Braun *et al.* 2008).

Furthermore, a wide range of bio-energy technologies exist, all of which (to various degrees) have significantly greater capital requirements than traditional biomass energy generation. The necessity of reliable, long-term, sufficient and affordable feedstock requires technical and institutional capacity that has long been identified as a major barrier to a host of other African development goals (Kartha *et al.* 2005). At the same time, the strong legislative incentives necessary to promote the broad diffusion of new energy sources are being led by traditional energy-consuming countries

¹⁹ For lack of a better term, recently developed biomass energy generating technologies will be referred to as producing ‘bio-energy’ while older technologies such as fuel-wood and agricultural residue burning for heat generation and charcoal production will be referred to as ‘traditional’ biomass energy.

in the EU and North America, as well as as the rapidly industrializing economies of Brazil, China and India, while “little effort” has gone into similar African reforms (Amigun *et al.* 2008). These constraints (including others) led a recent multi-year, multi-volume report on the future of energy supply in the Great Lakes region of Africa to ignore bio-energy completely amongst its host of RE options (Lavalin 2007).

The purpose of this paper is to review and evaluate the barriers and opportunities associated with bio-energy technologies, using global (and local) lessons to inform catalyzing them in Africa. This purpose will be fulfilled through a technical background (including biomass requirements, development and commercialization potential and examples), identifying key drivers and major obstacles, reviewing existing policies and institutional frameworks supportive to technological development and diffusion and, finally, reviewing capital and financing options for implementation.

7.3. WHAT TECHNOLOGIES ARE AVAILABLE FOR BIOMASS ENERGY GENERATION IN AFRICA?

Several variables differentiate bio-energy generation technologies, including: conversion process (thermochemical, biochemical and mechanical), feedstock type (annual or perennial), feedstock origin (dedicated or residual), scale of operations (large or small), energy end-use (heat, power or both) and the ultimate consumer (industry, utility, village, household) (Andersen *et al.* 2003; Dutschke *et al.* 2006). In order to simplify, this section is organized according to conversion process and end-product—with other aspects treated where they usefully contribute to the discussion (see Figure 7-1).

Figure 7-1: Bio-energy conversion processes

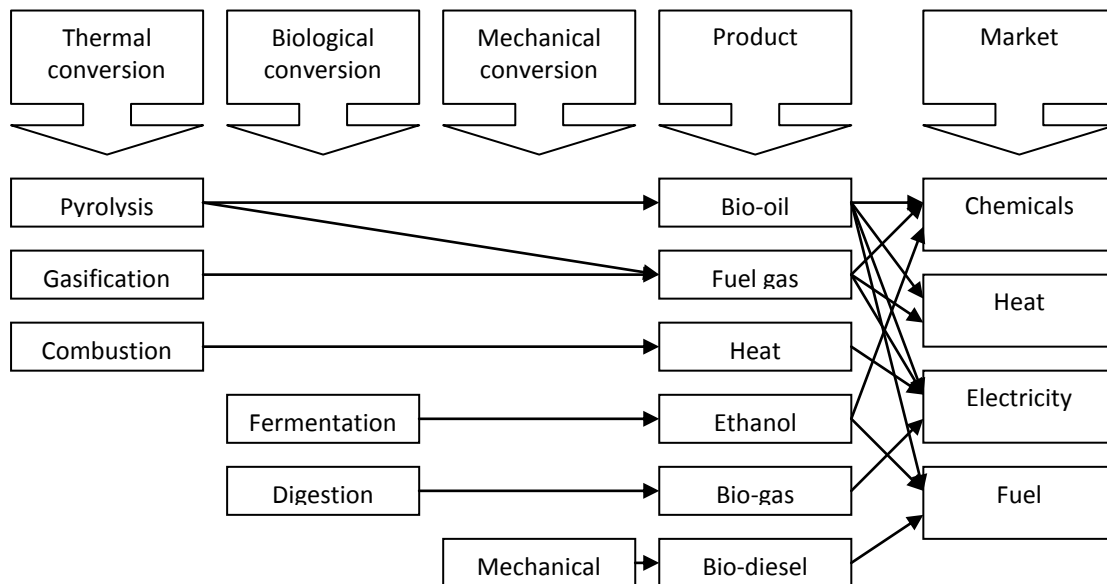

Source: after Bridgwater (2006)

The primary differences between thermal and biological conversion is the rate at which the process proceeds (seconds/minutes for thermal,²⁰ hours to years for biological), the temperatures at which they occur (over a broad range but at least several hundred degrees Celsius for the former, and ambient temperatures for the latter), and the complexity of the end-products, which can be much higher for thermal conversion (Bridgwater 2006).

Broadly, there are two sets of criteria for evaluating bio-energy systems: the first are technical and economic in nature, while the second refer to the livelihood impacts of application. With respect to the latter, the capacity of the technology to contribute to the MDGs is a useful rubric. For instance, while a combined heat and power (CHP) installation at a pulp mill may perform very well according to techno-economic criteria, it is a poor development tool for reducing poverty, increasing education or redressing gender inequity (though it may very well have important indirect impacts on environmental sustainability and human health).

The techno-economic considerations consist of the following: cost, load factor, efficiency, feedstock, scale and robustness (after Kartha *et al.* 2005).

- **Cost** – Producers and users tend to think of cost in different ways. That is, producers are primarily concerned with unit energy costs (per kWh), which demonstrate economies of scale. Users, on the other hand, are primarily concerned with use (reliability, convenience, safety, availability, initial investment) and often show a high willingness-to-pay if the technology performs well according to these criteria.
- **Load factor** – The average output of an energy system relative to peak output, this is a primary determinant of the success of a bio-energy system across all scales, since the fixed costs are borne by few users in low load factor environments. Typically, low load factors occur when generating capacity is significantly higher than demand. Securing a baseload source of demand is therefore critical to decreasing unit costs.
- **Feedstock characteristics** – Type of feedstock, moisture level and processing requirements are usually constrained by the chosen bio-energy technology.
- **Efficiency** – Heat/power generated relative to the volume of feedstock. Particularly if feedstock supply is constrained by geography or competition for end-use, efficiency becomes very important.
- **Scale** – While relatively easy to calculate for an industrial or energy-grid installation, the scale required is much more difficult to estimate beforehand for small-scale (village and household) applications, primarily because energy demand will increase (by a difficult-to-estimate factor) due to new activities or expanding incomes.
- **Robustness** – Poor maintenance and ill-adapted technology are commonly cited as reasons for failed rural bio-energy projects. The technology *must* be sufficiently mechanically reliable to operate in the target setting, explicitly including factors such as operating expertise and availability of repair parts. The more mature and proven a technology, the more likely is project success.

This paper covers the following technologies, with both general descriptions and examples of specific commercialised technologies in practice:

- Combustion of forestry and agricultural residues for heat and power generation
- Pyrolysis (including slow, for charcoal and briquettes, and fast, for bio-oil)
- Gasification of residues (for producer gas)

²⁰ With the exception of the appropriately named slow pyrolysis, which can be performed over a period of months.

- Anaerobic digestion of residues and wastes (for biogas)
- Biomass fermentation (for ethanol)
- Mechanical conversion of oil-seeds (for bio-diesel).

Emerging technologies will also be addressed, since second-generation bio-energy technologies have the potential to provide highly-efficient, low-cost heat and power with flexible feedstock requirements – leading some to recommend that regions without pre-existing infrastructure “leap-frog” first-generation bio-energy altogether (e.g. Woods 2006).

7.3.1. COMBUSTION OF RESIDUES FOR HEAT AND POWER GENERATION

Technologies for the direct combustion of either dedicated feedstocks (such as tree plantations) or agricultural residues are globally widely available and commercialized at domestic, industrial and utility scales, representing a mature, well-developed technology (Bridgwater 2006). They range in complexity from burning sticks on a three-stone fireplace to fluidized bed boilers providing several MW of heat and power (Dutschke *et al.* 2006). Furthermore, depending on scale and boiler design, these technologies can be used to provide greater flexibility by co-firing biomass with fossil fuels (usually coal) (Andersen *et al.* 2003).

When medium-scale to large-scale heat and power production are the goal, the base technology is burning biomass in a combustion boiler to convert water to steam, which expands through a turbine to generate power. These arrangements can range in size from 1 to 10 MW, and rarely up to 100 MW. Variations depend on whether the biomass is burned on a grate (fixed or moving) or fluidized with air or some other medium to encourage complete (and even) combustion. Efficiency is typically 40%, but can reach 70-80% with CHP.

A ready supply of biomass is critical, as is high demand to avoid low load factors. As a result, medium-scale to large-scale heat and power production are commonly associated with industrial sites that produce a large volume of forest products or agricultural residues, such as pulp and paper mills and sugarcane processing facilities where excess heat can be used in the industrial production process, leading to high efficiencies and the sale of energy into a regional grid. That is, efficiency and low-costs typically depend on the feedstock having a very low (or even negative) cost. Dedicated energy plantations increase the unit cost of power considerably—but where regions have large untapped supplies of residues generated by a medium- to large-scale industrial process (e.g. inefficient sugarcane processing facilities) the prospect for this technology is high due to its low unit-cost, high load-factors, flexible feedstock requirements and robustness – see Table 7-1 (FAO 2008; Kartha *et al.* 2005).

Several emerging combustion technologies also exist that have yet to be widely demonstrated or commercialized, and should therefore be considered only as long-term prospects. These include biomass integrated gasifier/gas turbines (BIG/GT), microturbines and Stirling engines:

- BIG/GT systems combine standard combustion technology with large-scale biomass gasification, leading to higher capacity and improved efficiency. Demonstration projects in Sweden, UK, Italy and Brazil are currently underway.
- Microturbines are designed for small-scale capacity (< 100 kW) and have been commercially available since 1999, and can provide village-scale power generation for low capital costs, though they remain far from cost-effective relative to diesel engines.
- Stirling engines are external combustion engines, permitting use of a wide range of feedstocks relative to internal combustion engines, but there have been no large-scale or commercial sales of Stirling engines to date (Kartha *et al.* 2005).

Table 7-1: Summary of biomass combustion for steam turbine power (and heat)

Variable	Description
Scale/application	Medium to large industrial
Energy provided	Electricity, heat
Electrical capacity	1 to 50 MW
Equipment	Boiler, steam turbine, de-aerator, pumps
Feedstock	Any (boiler design varies for each) of 1-2 dry kg/kWh, or 6,000 - 13,000 dry tonnes/year per MW
Availability	Manufactured in most large developing countries
Key costs	Initial capital investment, feedstock (if not low or negative cost)
Environmental concerns	Particulate emissions, thermal pollution, ash disposal
Employment	2 per MW (up to 10 MW), or 1 per MW (over 10 MW) based on projects in California
Capacity requirements	20% of employees at a high skill level, 75% at a moderate skill level, 5% at a low skill level

Source: Kartha et al. (2005)

Box 7-1: Riberalta Biomass Power Plant (Bolivia)

Until 1996, the city of Riberalta (population 600, 000) was dependent on diesel generators for power. In 1995, construction began of a biomass combustion plant using the residues of Riberalta's primary industries: tropical hardwoods and Brazil nuts. The project was co-financed by USAID and the National Rural Electricity Cooperative Association (NRECA). The plant was completed in 1996, and currently produces 12,000 – 20,000 kWh/day, from a feedstock of 80% Brazil nut shells (2.5 kg/kWh) and 20% wood chips (5 kg/kWh), displacing 4,000-6,670 litres/day of diesel at a construction cost of US\$2.2 million and electricity generating cost of 0.075 US\$/kWh (slightly over 50% the local cost of diesel). It provides electricity to the 4,500 members of the Riberalta Electricity Cooperative.

The plant developed major operating problems in 1999 and had to be taken off-line for a year's worth of repair. Investigation by NRECA revealed that operators had not received adequate training and maintenance had been neglected. Hiring a new operating crew and highly qualified plant supervisor addressed these problems and the plant has been operating without problem since.

The plant has also faced increased costs in its feedstock: Brazil nut shells were initially zero-cost fuel, but their use as feedstock has increased their price. Nonetheless, the plant is still economically competitive, as higher Brazil nut costs have been compensated by phasing out diesel subsidies.

This case highlights some key factors in bio-energy performance and profitability: the importance of specializing in a locally-abundant, low-cost feedstock; synergies that exist between bio-energy and the agriculture and forest products industries; the importance of attracting and developing well-trained operators and managers; and the necessity of enabling national policies to redress bias in favour of fossil fuels.

Source: Kartha et al. (2005)

7.3.2. PYROLYSIS

Pyrolysis is the thermal decomposition of biomass in low oxygen conditions, preventing complete combustion and reducing the biomass to a combination of simple molecules (Andersen et al. 2003; Bridgwater 2006).

At one level, pyrolysis is very well known, and at another it is a largely unknown, emerging technology. That is, **slow pyrolysis** has been practiced globally for millennia, primarily through charcoal production: wood (and sometimes other biomass) is heated ($\sim 400^{\circ}\text{C}$) slowly in an enclosed space—usually an earthen pit or mound—over the course of weeks to months. Water and gases are released, leaving behind primarily carbon. Maximum energy efficiency is 25% (Kartha *et al.* 2005).

Charcoal and other traditional biomass energy sources, such as combustion of fuelwood, manure and crop residues, are the primary sources of household energy for 2-3 billion people world-wide, and thus represent a familiar, commercialized and mature technology (especially in Africa, where it meets more than 90% of household energy needs in many countries) (Kammen 2006).

Charcoal is a preferred fuel for many urban traditional biomass energy consumers, because it burns with much less smoke, produces less indoor air pollution, and is more easily stored and transported than fuelwood (Kartha *et al.* 2005). Furthermore, its production is often subsidized, either indirectly or directly, by the state through allowing charcoal producers free access to national forests.

While more efficient production can make an important contribution to improving energy efficiency, myriad projects have met with, at best, mixed success, largely because of distortionary policy (that is, there is no incentive to improve production efficiency if the costs of the raw materials are nil) (Kammen, 2006). Improved cookstove designs (i.e. smokeless, high efficiency, low cost) are now common, but dissemination has proven difficult, primarily because performance tends to depend strongly on 1) precise design parameters that are difficult to replicate by semi-skilled labourers, 2) cooking habits, which many users are unwilling to change, and 3) feedstock characteristics, which are highly variable.

Fast pyrolysis, on the other hand, takes place at a moderate temperature ($\sim 500^{\circ}\text{C}$) with no oxygen, and sometimes at elevated pressure, to reduce the biomass to a small amount of charcoal and coke with a large amount of vapour and aerosols which are rapidly cooled to form a liquid known as *bio-oil*.

While slow pyrolysis produces $\sim 35\%$ solid and 35% gas, fast pyrolysis can produce up to 75% liquid. Bio-oil is dark brown and has a heating value $\sim 50\%$ of conventional fuel oil, and can be produced by almost any form of biomass with dry moisture content less than 10%. Like conventional oil, it is easily stored and transported and has been successfully combusted for use in engines, turbines and boilers (Bridgwater 2006; Dutschke *et al.* 2006).

The capital requirements are much higher for fast pyrolysis than slow, requiring similar boiler technology as direct combustion for power generation (Dutschke *et al.* 2006). Further, it is at a much earlier stage of technological development, with demonstration plants of various boiler configurations in Canada, Germany the Netherlands and Malaysia (Bridgwater 2006). Only one commercial heat-generating bio-oil system exists—Red Arrow Products in Wisconsin (USA) with a 5 MW capacity, though it is also being promoted in Brazil as a means to improve charcoal production and promote bio-refineries (Pelaez-Samaniego *et al.* 2008).

When used in engines, the lower volatility, high viscosity and high corrosiveness of bio-oil makes it problematic with current designs. It can be upgraded to a conventional transport fuel (requiring complete deoxygenation) but this is accompanied by high processing costs, leaving it not cost-competitive with fossil fuels. However, in a future bio-refinery context, bio-oil could be an important low-cost source of hydrogen, given adequate demand for its by-products (Czernik and Bridgwater 2004). Dynamotive Energy Systems Corporation (Canada) is currently building a commercial bio-oil plant that will eventually process 200 tonnes/day of waste wood residues to produce 175 tonnes/day of bio-oil for sale as industrial fuel.

Given the lack of current, demonstrated, commercial application of fast pyrolysis, questions of scale and capacity requirements cannot be definitively answered. It is an unknown, with limited potential in the short and medium term to contribute to bio-energy supply in Africa.

Box 7-2: Mitigation of methane emission in charcoal production (Brazil)

The Brazilian pig iron company Plantar is heavily dependent on charcoal produced in low-efficiency, traditional kilns. Higher efficiency kilns, while long known to significantly reduce emissions from slow pyrolysis, are not cost-effective given the lack of methane emission restrictions in Brazil.

Accordingly, Plantar was an early partner with the Prototype Carbon Fund of the World Bank to establish 23,000 ha of eucalyptus plantations on degraded pasture for use as dedicated feedstock for high-efficiency charcoal production. Greater control of wood moisture, temperature and carbonization time result in significant reductions in methane emission in production, while use of renewable charcoal in pig iron production further reduces emissions. Concentration of atmospheric greenhouse gases are therefore reduced in three different ways: increased average carbon in the landscape (from afforestation), decreased emissions from charcoal production and decreased emissions from pig-iron production.

This project is currently the only emissions-reduction-from-charcoal production project registered under the Clean Development Mechanism (CDM) – the revenue from sales of credits being the only means by which the investment in improved kilns is commercially justifiable for Plantar.

However, this project has not been without controversy. Dozens of European and Brazilian NGOs have argued that, as a result of Plantar's larger forest management operations and faulty assumptions about the future availability of charcoal in Brazil, the carbon neutrality of charcoal consumption in pig iron production is not supported by the evidence. Nonetheless, this project demonstrates the potential importance of the CDM in promoting the commercialization and development of bio-energy.

Source: CDM (2006)

7.3.3. GASIFICATION²¹

Thermochemical gasification is a continuation of pyrolysis at higher temperatures (~800°C) in the absence of an oxidizing agent—yielding 85% gas with a small amount of liquid and char.

This gas is known as **producer gas** and consists of 18-20% hydrogen, 18-20% carbon monoxide, 2-3% methane, 8-10% carbon dioxide and 50% nitrogen (Andersen *et al.* 2003; Bridgwater 2006).²² Its energy content is approximately 10-15% that of natural gas, and it can be used in internal combustion engines to generate electricity or rotation.

Gasification boilers have been in use for over a century and have been widely available in large developing countries—forming the basis of rural electrification projects until the 1980s, when they were largely abandoned due to project failure (Dutschke *et al.* 2006). The primary source of this

²¹ The phrase “gasification” can be problematic, as there are two means to transform biomass into gases that are useful energy sources. The first is a thermochemical process and yields producer gas; the second is a biochemical process and yields biogas. The former will be referred to as gasification and treated in this section; the latter will be referred to as anaerobic digestion and treated in Section 7.3.4.

²² Depending on convention, feedstock and end-use, producer gas is alternately referred to as wood gas, town gas (gasified coal), and syngas, though this paper will use the general term.

failure was the residual liquid from the gasification process, which forms tars that condense on downstream equipment. Charcoal can be used instead of direct biomass gasification to overcome this difficulty, but it is much less efficient because of the energy lost in charcoal production, and the charcoal is more costly than the raw biomass (Kantha *et al.* 2005). Additionally, while producer gas has been widely applied since the 18th century in domestic, industrial, power generation and motor vehicle operations, it is accompanied by a significant health risk: it is odorless, and since ~20% of producer gas is carbon monoxide, accidental leaks can be lethal (Dutschke *et al.* 2006).

Nonetheless, the basic application of this technology is well-known and commercialized, with manufacturers' performance warranties available and new techniques that significantly limit tar production. However, these techniques remain new and are more complex, as a result having greater production and capital costs. Consequently, electricity costs are higher than those for a coal or natural gas facility. The scope of operation of gasification engines is therefore limited to locations where electricity is unreliable or unavailable: if compared with the cost of extending a transmission and distribution system from a centralized coal-burning facility, they are quite competitive. For electricity generation, producer gas is also typically co-fired with diesel fuel, adding a potentially significant component to costs.

Table 7-2: Technical summary of biomass gasification

Variable	Electricity	Cooking gas	Heat
Scale/application	Small- to medium- scale		
Energy provided	Electricity, rotation	Heat	Heat
Electrical capacity	5-500 kW	10-1200 Nm ³ /hr	40-5000 MJ/hr
Equipment	Gasifier, gas cleanup, diesel engine	Gasifier, gas cleanup, gas distribution, stove	Gasifier and furnace
Feedstock	Wood chips, corn cobs, rice hulls, cotton stalks, coconut shells, palm nut shells, soy husks, saw dust, biomass briquettes		
Availability	Several multinational corporations and domestically in some large developing countries		
Feedstock input	1.0-1.4 kg biomass + 0.1 L diesel / kWh	0.1-0.15 kg biomass / MJ	
Key costs	Capital, diesel fuel, labour	Capital, labour	
Environmental concerns	Wastewater cleanup, clean combustion		
Employment	Small, increases with labour intensity of biomass collection		
Capacity requirements	Low to medium skill level for operator		

Source: Kantha *et al.* (2005)

The key to satisfactory performance (assuming high load factors) is adequate cleaning of tars from the gas. The remaining solid residue can be used as mineral fertilizer or, in the case of rice husk ash, as construction material (Kantha *et al.* 2005).

Large-scale commercial and demonstration examples are being developed but remain limited in distribution. The UK firm Biomass Engineering has been successful at developing atmospheric downdraft gasifiers of up to 1.5 MW with effective tar elimination. Atmospheric bubbling fluidized bed gasifiers are reliable for several feedstocks at a pilot and commercial scale up to 25 MW, but with few operational examples. Atmospheric circulating fluidized bed gasifiers are very reliable and scale up to 100 MW—becoming the preferred systems for large-scale applications, for instance the Termiska Processor AB and Varnamo (Bridgwater 2006). The most successful biomass gasifier

currently operating for power generation is the Gussing gasifier in Austria, generating 2 MW and having completed more than 15,000 hours of operation at the end of 2005.

Since 2000, small- and medium-scale biomass gasifiers have been commercialized in China and Southeast Asia with costs of 0.045-0.055 €/kWh in operating costs, and 500-700 €/kW in start-up costs (Yang and Yin 2008). However, at large scales sourcing adequate biomass supply becomes an important logistical challenge that significantly increases costs.

Box 7-3: DESI Power Gasifier (India)

This demonstration gasifier was installed in Orchha, Madhya Pradesh, by a non-profit association that promotes renewable energy in India. It has an 80 kW capacity and supplies power primarily to a local college for consumption by its research and paper-manufacturing facilities. It uses approximately 1 tonne/day of a common weed (Ipomea), which must be harvested, chopped and dried before it can be used in the gasifier. Experiments with vertical integration (in which gasifier managers produced the weed) demonstrated a market-oriented approach of purchasing Ipomea from local suppliers resulted in improved performance. Cogenerated heat from engine exhaust is also used by the facility for its paper production activities – improving its economic performance.

The gasifier has been operating for 10-12 hours/day since 1996, with costs of less than 0.10 US\$/kWh. Two elements have been critical to profitability: load factor and feedstock cost. In the former case, a load factor of 50-60% is necessary for electricity to be produced below the grid price. In the latter case, the long-term nature of the project has revealed that Ipomea biomass per hectare significantly decreases after the first harvest, requiring an increasing feedstock producing area over time. This has led to the necessity of experimentation with alternative fuels.

This example highlights the following key factors: the importance of establishing as broad a range of clients as possible to ensure a high load factor; designing operations based around abundant feedstocks, with a gasifier of flexible feedstock requirements preferred; and the importance of demonstration projects to develop the technical knowledge of gasifier function that can only come from learning-by-doing.

Source: Kartha et al. (2005)

7.3.4. ANAEROBIC DIGESTERS

Anaerobic digestion exploits the metabolism of microbes in oxygen-deprived environments to digest organic matter and exhale methane. Since the conversion process is undertaken by living organisms, it takes place at low temperatures (ambient) and the product is known as *biogas*, which typically has a composition of 60% methane and 40% carbon dioxide (Andersen *et al.* 2003).

Like producer gas, with appropriate treatment biogas can be combusted for cooking and/or heating or used in internal combustion engines to produce electricity or rotation. Biogas can be produced from sewage sludge, crop residue, carbon-intensive industrial by-products, landfill wastes, and practically any other plant or animal waste (excepting lignin) (Kartha *et al.* 2005). As a result, anaerobic digestion is particularly well-suited for areas with abundant organic waste associated with sanitation concerns—such as landfills, sewage treatment facilities and abattoirs—improving sanitation while at the same time delivering fuel and fertilizer (as a by-product) (Andersen *et al.* 2003).

A wide array of commercial technologies exist at multiple scales with performance guarantees (Bridgwater 2006). Generally speaking, feedstock is collected, shredded and deposited in a reactor with an active inoculum of microorganisms. The reactor is mixed and fed at least once per day and

maintained at a temperature of 35°C, yielding methane-rich gas and solid residues. Innovations on this technology involve reducing reactor size, reducing energy requirements, and improving solids and microorganism retention (Chynoweth *et al.* 2001).

Table 7-3: Technical summary of anaerobic digestion

Variable	Household/Village scale		Industry/Municipality Scale	
	Electricity or rotation	Cooking gas	Electricity	Fuel
Electrical capacity	3-10 kW	2-100 Nm ³ /day	500-15 000 kW	10,000-200,000 Nm ³ /d
Equipment	Digester, diesel engine, sludge filter/drier	Digester, sludge filter/drier, gas storage/distribution burner/stove	Digester, gas cleanup, gas engine, sludge filter/drier	Digester, gas cleanup, storage, sludge filter/drier
Feedstock	Fresh animal or human manure, crop straw, leaves, grass		Sewage sludge, food processing or food wastes, distillery effluents, animal manure	
Availability	Widely available, can be built with mostly local materials		Sold/produced in many countries by many companies	
Feedstock input	~14 kg fresh dung + 0.06 L diesel / kWh	~30 kg fresh dung + 30 L water per Nm ³ biogas	Varies with feedstock	
Key costs	Capital, diesel fuel, labour		Capital	
Environmental concerns	Incomplete pathogen destruction		Insufficient chemical or biological oxygen demand	
Employment	Small, increases with labor intensity of biomass collection			
Capacity requirements	Low to medium skill for operator			

Source: Kartha *et al.* (2005)

Small-scale biogas production is the simplest of bio-energy production technologies, and has been distributed extensively throughout South and East Asia, in particular. The fertilizer by-products and sanitation benefits make anaerobic digestion a particularly strong candidate for bio-energy production, as does its non-toxic nature (Kartha *et al.* 2005).

Early digester diffusion programmes faced significant maintenance problems: one-third of the 1.85 million cattle dung digesters installed in India in the 1990s were not operational by 2000. The secondary cause of failure was inadequate dung supply to maintain the microorganisms. A similar failure rate for pig and human manure digesters was experienced in China in the 1970s, for similar reasons. Nonetheless, digesters are still promoted in each country, and China has over 500 large-scale digesters at pig farms, and 24,000 digesters at urban sewage treatment plants. Furthermore, South Korea, Brazil, Thailand and Nepal also have active digester promotion programmes (Kartha *et al.* 2005).

The Nepalese programme (known as the Dutch-Nepalese Biogas Support Programme) has installed ~120,000 units in the last 13 years, with an ongoing ~20,000 units per year and a high success rate. They provide ~3% of Nepalese homes with lighting and cooking fuel, and roughly 72% connect to latrines, with noticeable improvement in human health. Furthermore, the programme is registered under the CDM, with each plant credited with removing 4.6 tonnes of carbon dioxide-equivalent per year (tCO₂e/year), worth approximately US\$18/year (UN Energy 2007).

In the case of electricity production, cost per unit energy is highly scale-dependent, but large-scale digesters (>300,000 GJ/year) can produce at US\$1-2/GJ (less than 0.07 US\$/litre of diesel equivalent), though this is dependent on low-cost (or no-cost) feedstock.

Attempts to produce a large-scale biogas plant in Africa have been made—a Global Environment Facility (GEF) financed project in Dar-es-Salaam was cancelled because of technology selection problems and institutional constraints (Amigun *et al.* 2008).

Box 7-4: Pozo Verde Farm Anaerobic Digestion (Columbia)

The purely commercial activities of this integrated farm in the Cauca Valley have been supplemented by two digesters in continuous operation since 1986, employing 20 persons. This project was completely non-subsidized, though technical advice was provided by the Columbian Research Center for Sustainable Agricultural Production Systems (CIPAV).

The first digester is attached to a building for pregnant sows, which produces over 900 m³ of wastewater per year. It is treated by two tube biodigesters and a channel of water hyacinth. Channel sludge and plants are used to fertilize crops, and the biogas is stored and used to generate electric power in a diesel engine. The second digester processes wastewater from a dairy stable and lactating sow and pig fattening buildings (12,500 m³ waste per year). Effluent is stored in a tank, and then fertilizes over 30 ha of pastures and crops. Biogas is used in burners to warm piglets, as well as being piped to the diesel engine.

A wide array of environmental and economic benefits has resulted from this system – linking waste treatment with energy production. This example highlights the immediate commercial competitiveness of biogasification at a variety of scales, and its ability to provide sustainable energy solutions, particularly when utilized primarily for waste treatment.

Source: Kartha et al. (2005)

7.3.5. ALCOHOLIC FERMENTATION

Alcoholic fermentation, like anaerobic digestion, exploits the metabolism of single-celled organisms in oxygen-deprived environments – in this instance, their consumption of sugars to produce ethanol and carbon dioxide. This is a very familiar technology that has been well-developed across all inhabited continents for millennia.

Together with biodiesel (which is treated in the following section), ethanol production for bio-energy is typically referred to as a *biofuel*. The “first generation” of biofuels are derived directly from food crops, in particular sugarcane, sugar beet, maize, sorghum and wheat (Dutschke *et al.* 2006). This has raised a significant objection to their further promotion: they can divert agricultural production away from food crops toward energy production and thereby increase the price of basic cereals (von Braun *et al.* 2008).

This concern (as well as that surrounding the large amount of plant residues left un-used by large-scale ethanol production) has led to the development of so-called “second generation” biofuels, which are derived from feedstocks not traditionally directly consumed by humans: the majority of second generation biofuels use a combination of acids and enzymes to convert plant cellulose into ethanol (known as *lignocellulosics*) (Charles *et al.*, 2007).

While second generation biofuels hold great promise for future fuel production, they are not yet commercially available. Though there are a number of large-scale demonstration facilities, these will

likely require at least another decade before they are competitive with fossil fuels. First-generation ethanol fuels are well-developed and commercial, with performance guarantees from multinational corporations and complete cost competitiveness with fossil fuels (depending on production costs) (Bridgwater 2006; FAO 2008). Furthermore, fermentation has the benefit of producing a by-product (distillers dried grains with solubles) that is a nutritious livestock feed, as well as having a positive net energy balance (that is, it takes less energy to produce ethanol than the product ultimately created) (Dutschke *et al.* 2006).

Two types of ethanol for bio-energy are commonly produced: anhydrous (100% ethanol) and hydrous (which includes 5% water). The former can be blended (up to 25%) with gasoline and used by standard gasoline combusting engines. The latter cannot, but can be used as a fuel (called a *neat* fuel) in internal combustion engines designed for that purpose. Furthermore, when mixed with a cellulose thickening agent it forms a gel that can be used very effectively in cookstoves, and is widely available in Zimbabwe and South Africa (Kartha *et al.* 2005).

While a number of crops are available for commercial ethanol production for bio-energy, the most common are maize (in the USA, where maize is referred to as “corn”) and sugarcane (in Brazil, and worldwide) (FAO 2008).

Sugarcane is most common because it is the most energy-efficient and lowest cost of first generation biofuel feedstocks (depending on growing conditions) and is already widely grown (in 80 tropical countries) (Andersen *et al.* 2003). In most countries growing sugarcane for bio-energy, anhydrous ethanol is produced for blending as a transportation fuel. Brazil, however, has focused on ethanol production as a petroleum substitute (in addition to fuel enhancing). In the Brazilian case (centred on the state of Sao Paulo), production is large scale and capital-intensive, and the cost of feedstock is over half of the per unit labour production costs – emphasizing the importance of high productivity cane production. Use of the sugar production residues (*bagasse*) and the agricultural residues (*barbojo*) in combustion and gasification are promising (and well-developed) ways to improve efficiency while generating electricity. A technical summary of Sao Paulo sugarcane production for ethanol is found in Table 7-4, though it must be emphasized that ethanol production costs are very site-specific (Amigun *et al.* 2008; Kartha *et al.* 2005).

Table 7-4: Technical summary of alcoholic fermentation of sugarcane in Sao Paulo

Variable	Description
Scale/application	Medium to large industrial
Energy provided	Liquid transportation fuel
Unit capacity	120,000 litres / day
Equipment	Sugarcane juice extraction, fermentation, distillation
Feedstock	Sugarcane (1,500-1,700 tonnes / day)
Availability	Commercially available, especially from Brazilian companies
Key costs	Sugarcane feedstock, capital investment
Environmental concerns	Groundwater contamination by stillage, cane field burning, soil degradation
Employment	1,600 to 6,400 per million tonnes of sugarcane processed per year (agriculture), 600 per million tonnes of cane (distillery).
Capacity requirements	30% of employees at a high skill level, 10% at a moderate skill level, 60% at a low skill level

Source: Kartha et al. (2005)

Note that competitiveness with fossil fuels depends on the price of oil being greater than US\$30/barrel, as well as labour costs and foreign exchange savings (Kartha *et al.* 2005).

Sao Paulo state has the most productive sugarcane agriculture in the world. Attempts to emulate its programme have been made throughout the tropics. Particularly in Africa, results have been mixed, and most have been focused on certain members of the Southern African Development Community (South Africa, Malawi, Swaziland, Mauritius and Zimbabwe). Considerable potential exists in Ethiopia, Zambia and Mozambique, but resistance from the petroleum industry has significantly slowed the pace of development (De Castro 2007).

Box 7-5: Triangle Ltd (Zimbabwe) and ETHCO Ltd (Malawi)

Two examples of African ethanol production are instructive as responses to the oil-price shocks of the 1970s. Both distilleries were constructed next to existing sugar factories to assure adequate molasses feedstock.

Triangle began production in 1980, from company-owned sugarcane processing facilities, with blending ratios of 8-13% by volume established by the national oil company. Production ranged from 30-40 million litres/year throughout the 1980s. A drought in the early 1990s severely limited sugarcane production and, therefore, blending. Once ethanol production resumed, the oil company and Triangle were unable to re-establish blending procedures, and inadequate political will (combined with new policies and tax incentives for encouraging exports) focused Triangle on the export market. Triangle is again in operation at its earlier levels of productivity, but its output is no longer blended as a fuel: it is exported for the solvents industry.

ETHCO has produced 15-20 million litres/year since 1982 for blending of 15-22%. It was not as affected by the drought as Triangle because of its superior access to irrigation water. However, it has also faced feedstock supply difficulties. It purchases molasses on the open market, and price fluctuations have required it to source up to 40% of its molasses from a factory several hundred kilometres distant, and not solely from the adjacent plant. While this has enabled it to continue to produce cost-effective blended ethanol, it has reduced the environmental benefits of the enterprise, as a result of diesel combustion in the transportation of the feedstock.

These two examples highlight the following key factors in ethanol production: enforced national blending targets; low-cost, available feedstock; the role of international price fluctuations and non-energy specific national policies; and the often contentious relationship between RE firms and fossil fuel companies.

Source: Kartha et al. (2005)

7.3.6. BIODIESEL

Biodiesel is, together with ethanol, the other common biofuel. Unlike ethanol, however, it does not exploit microbial technology in its production.

Vegetable oil is mechanically separated from oil plants and then treated with ethanol in a process known as *transesterification* which chemically converts the oil to a mono alkyl ester ($C_{19}H_{36}O_2$). The resulting "biodiesel" performs very similarly to petroleum-based diesel fuel (Kartha *et al.* 2005). While a diesel engine can run on the raw vegetable oil, performance is superior if it has first been processed by this low-cost procedure into biodiesel (Andersen *et al.* 2003).

Given that oilseed crops are more globally widespread than sugar crops, a variety of vegetable oil crops have been used including palm oil, sunflower seed, cottonseed and *Jatropha curcas* (as well as used frying oil) although the most common are soy oil and rapeseed oil (FAO 2008; Kartha *et al.* 2005). The type of dominant vegetable oil used in a region depends on the locally available crop that maximizes oil productivity—high oil yield being the key to cost minimization (Andersen *et al.* 2003). Currently, most biodiesel production takes place in Europe from rapeseed oil, though Malaysia and Indonesia produce significant amounts from palm oil, and the Philippines and India are experimenting extensively with *Jatropha* (FAO 2008).

Probably the most important contribution of biodiesel to the bio-energy discussion is that it requires very few, if any, modifications to pre-existing diesel infrastructure. Typically, it is mixed with petroleum diesel at a 20:80 ratio (B20), for which no engine modifications are required. B100 often improves engine performance over standard diesel, though some modifications are necessary (Karthan *et al.* 2005). Since biodiesel is a solvent, it cleans engines during operation, but this cleaning action can block the fuel filter as sediments accumulate (De Castro, 2007). Furthermore, biodiesel is safer to burn (it has a higher flashpoint), it is biodegradable, and reduces net GHG emissions significantly (Karthan *et al.* 2005).

Experience with biodiesel in Africa is widespread, but small-scale. Mali for example has 10,000 km of *Jatropha* hedges and is planting an additional 2,000 km/year. The government of Mozambique is currently investing in policy and small projects to achieve a national goal of 5% biodiesel blending (De Castro 2007). A number of small-scale projects exist based on commercially available mechanical processing units which are easy to operate with only a small-amount of training (Bridgwater 2006). Diesel engines, of course, are widely available and familiar throughout the tropics.

Box 7-6: Multi-functional platforms (Tanzania)

Jatropha has been used in Africa for decades for windbreaks, erosion control and oil production, but has increasingly been a focus for biodiesel production. In 2006, the Tanzania Traditional Energy Development and Environmental Organization (TaTEDO) funded several projects to promote Multi-Functional Platforms (MFPs), typically a 10 hp biodiesel engine that drives a press for producing *Jatropha* oils, and a generator for providing electricity, a mill for grinding cereal or a compressor for inflating tires. When *Jatropha* oil is unavailable, MFPs can run on standard diesel, though this doubles operating costs. The MFPs themselves are operated commercially by an individual entrepreneur selected by local villagers, who operates the MFP, collects connection/service fees and performs/contracts maintenance. The entrepreneurs are trained by TaTEDO in operation, management and entrepreneurial development.

Experimentation within the project has demonstrated significantly increased efficiency when the MFP is operated commercially by an entrepreneur over other options. This project has established MFPs at 3 sites, which included the construction of a village mini-grid to 50 households (3 US\$/month flat rate) and 12 businesses (5 US\$/month).

The primary challenge the project has faced is a lack of consistently available quality feedstock: awareness of *Jatropha* remains low in Tanzania and ingredients for local biodiesel processing remain scarce. This project highlights the feasibility of small-scale biodiesel production in rural Africa, as well as the importance of establishing a consistent, high-quality feedstock supply.

Source: DESA (2007)

7.3.7. CONCLUSIONS

In addition to providing a brief description of existing bio-energy technologies, this section has identified several important elements in their commercialization through a series of examples of the technologies in practice. In particular, the importance of low-cost, available feedstock supply has been highlighted, as have opportunities for public-private partnerships, international financing, an enabling policy environment and the role that bio-energy technologies can play in meeting non-energy goals (such as waste management). However, before the applicability of these models to African contexts can be productively discussed, the drivers of bio-energy technology development and the barriers they face must be discussed.

7.4. WHAT ARE THE KEY DRIVERS OF THESE TECHNOLOGIES AND THE PRIMARY OBSTACLES THEY FACE?

The primary drivers of the development of bio-energy technologies, and their increasing commercialization in much of the world, are similar from region to region, with variations depending on local context. Broadly, they can be reduced to: energy security, atmospheric GHG stabilization, rural income support and job creation, increased resource management efficiency and combating poor sanitation and pollution-induced human health crises.

It is critical to note from the outset that none of these five drivers is necessarily linked to bio-energy production—there are a host of other, more familiar, strategies by which governments, corporations and communities may meet these goals. This inherent indirectness of the link between drivers and technologies exposes the further development of bio-energy technology (particularly in Africa) to a host of obstacles that must be addressed for its development to continue.

In this section, primary reference will be made to the experience of the EU, US and Brazil, which have long-established and well-studied bio-energy programmes, and therefore for whom drivers and obstacles are better identified. Important reference will also be made to the bio-energy experiences of India and China, which may have a more immediate bearing on African contexts.

7.4.1. BIO-ENERGY TECHNOLOGY DRIVERS

The primary driver of biomass energy development in the EU, USA and Brazil is the desire to diversify sources of energy and increase energy supply security (Ballard-Tremeer 2007; Charles *et al.* 2007; FAO 2008). The oil embargoes of the Organization of Petroleum Exporting Countries (OPEC) and subsequent global oil crises of the 1970s prompted the conception of many currently important national bio-energy programmes. The potential to produce bio-energy wherever there is adequate biomass feedstock gives it an important geographical flexibility relative to other energy sources.

Given the concern in many parts of the world relating to anthropogenic climate change, and the ability of bio-energy to potentially offer net zero GHG emission energy, there is a natural association between climate change mitigation efforts and developing sources of bio-energy. Certainly, this has been an important policy driver in the EU—though the broader framework for EU bio-energy promoting policies was in place long before climate change rose to its current level of influence (Ballard-Tremeer 2007). Certainly, it has not been nearly as important a driver in the US, Brazil, India or China.

Rural income support and job creation have been critical in driving bio-energy in the EU, US and Brazil. In the EU, a significant portion of bio-energy programmes form part of a much broader package of rural income support under the Common Agricultural Policy (CAP), which has been revised several times to support bio-energy (Henniges and Zeddies 2006). In the US, bio-energy development grants have been important components of recent Farm Bills designed to maintain the viability of rural regions and states (UNCTAD 2006). In 2004, the Brazilian sugarcane sector produced 700,000 direct jobs, and 3.5 million indirect jobs—which has been an important motivation for continued support of the ethanol industry (De Castro 2007). In this respect, bio-energy is simply one of a host of means to support rural livelihoods.

Less important, though still widespread, is the desire to improve the efficiency of resource management—not necessarily in terms of energy or economic efficiency, but in terms of mass efficiency. That is, the desire to minimize waste is an important driver of bio-energy technology. In the case of Brazil, sugar production has long produced significant waste in the form of bagasse and barbojo, and ethanol production has increasingly efficiently consumed these by-products (Kantha *et al.* 2005). Throughout the temperate and boreal forests of North America and Europe, significant

volumes of logging residues (as well as millions of hectares of insect and fire-killed forests) have historically been unused: many of them are now used by the forest industry to export power to the centralized energy grid (Andersson *et al.* 2002). In increasingly “waste” conscious societies, this is an important bio-energy driver (Charles *et al.* 2007).

Finally, while unimportant in either the EU or US, and while yet to be seriously exploited in Brazil, bio-energy has been driven strongly in China, Nepal and India by concerns over sanitation and pollution (Best and Christensen 2003). Biogas production from anaerobic digestion, in particular, can operate on a large-range of scales commercially, and has been used in these countries to solve health and environmental problems created by household sewage, intensive animal husbandry/slaughter and poor urban waste treatment. Noticeable improvements in local health and environments have been reported (Kantha *et al.* 2005; UN Energy 2007).

7.4.2. APPLICATION OF DRIVERS TO THE AFRICAN CONTEXT

While it is not difficult to see why these considerations would drive bio-energy development in the regions considered, it is not clear that the same drivers are present in Africa, or at least to the same degree. While energy security is a concern in Africa, since energy demand is currently not met (as it is in Brazil, the EU and USA) and is expected to grow, energy programmes are more likely to be driven by their ability to deliver stable, safe, inexpensive heat and electricity, rather than the source (external or domestic) of the energy (FAO 2008). Bio-energy may underpin such programmes, but not explicitly because of its attendant energy security benefits.

Income support and promotion of rural livelihoods is a topic high on the agenda in African contexts. As such, it has important potential to drive bio-energy development in Africa just as it has driven it in the EU, USA and Brazil. However, in these contexts this process is part of a broader, high cost domestic support system subsidized by urban dwellers. Given limited investment funds and the current emphasis in African policies on developing sustainable cities, it is questionable whether this process will be funded domestically.

The desire for improved efficiency in resource use remains a potentially strong driver of African bio-energy. However, it will be necessarily limited to regions with developed (or developing) forest and agricultural industries. That is, the mass efficiency of small-scale, rural production is already very high in Africa, residues being used for fuel and agricultural productivity improvement (e.g. compost and mulch). There is little excess biomass to drive bio-energy. However, regions and nations with active forest products industries, actual or potential for productive sugarcane industries and large-scale brewing, will have significant volumes of waste residue that could drive bio-energy development. Bio-energy promoting policies should focus on these installations, as a strong driver exists.

In addition, the sanitation driver is potentially very strong. Given its success at a variety of scales in India, Nepal and China, it may be exploitable in the African context as well. Large- and medium-scale organic waste pollution resulting from urban sewage, abattoirs and hospitals have potential to drive the commercialization of anaerobic digestion in many countries, while simultaneously developing administrative familiarity and technical capacity with this option. Bio-energy policy which focuses on harnessing this driver has great potential.

This discussion of the drivers of bio-energy technology in the rest of the world, and their possible application to the African context, has demonstrated some opportunities for the effective development of bio-energy resources in Africa. However, the existence of a strong driver is not enough: bio-energy is only one of several potential responses to these drivers, and it faces specific barriers. The following subsection will discuss the barriers experienced in global bio-energy development to date.

7.4.3. BARRIERS TO BIO-ENERGY DEVELOPMENT

Given the breadth of experience with bio-energy that has been developed in response to these drivers, the barriers it faces have been well-described. The EU experience has identified the following 5 obstacles (from Ballard-Tremeer 2007):

- 1) **Opposition (both active and passive) of major energy suppliers and equipment manufacturers to bio-energy development.** This reluctance is hardly surprising given both a) the traditionally influential role that major fossil fuel industries have had on government policy in Europe and the US and b) that bio-energy generation is inherently more decentralized than fossil fuels, threatening the role of large, centralized energy distributors (both public and private) (Collier *et al.* 2008).
- 2) **Technology and process costs.** Outside of the combustion of residues from the forest products industry, bio-energy in Europe remains uncompetitive with fossil fuels.
- 3) **Lack of consumer awareness about bio-energy benefits.** This has led to objections by consumers and community groups to large bio-energy installations (Reich and Bechberger 2004).
- 4) **Fuel chain complexity.** While overall complexity is no less than that of fossil fuels, the fossil fuel supply chain is well-established and has been refined over more than a century of common use. Relative to other renewables, bio-energy is the only one whose “feedstock” cannot always be harnessed free of charge. This results in high costs and long-term commitments for non-residue/waste-based bio-energy in order to cover planting, management, transportation, densification, storage and/or transformation. This complexity has slowed the development of the market instruments which would decrease these costs, including quality standards, a specialized trading floor and dedicated transportation and storage facilities.
- 5) **Inappropriate and poorly-devised policy frameworks.** Given these barriers and the multitude of viable responses to bio-energy drivers, targeted national policies are necessary to encourage bio-energy development. Therefore, when policies are either absent, or communicate uncertainty with respect to the duration and level of financial support for bio-energy, they can act as a barrier. The EU Biomass Action Plan argues that this is the most important barrier to overcome, since, “it is convincingly proven that whenever appropriate policies are implemented, the market reacts positively and develops the necessary structures and operations systems to deliver results” (EU 2005).

There is no compelling reason to believe that any of these barriers will be weaker in Africa than they have been/are in the EU. The existing experience of bio-energy development in other less-developed regions (including Africa) has led to the identification of an additional 5 barriers, including the following:²³

- 1) **Land competition.** Non-waste/residue-based bio-energy faces competition from food crops and livestock to promote other livelihood values, notably food security. While this is a real

²³ These have been collected from a number of sources, including Kartha *et al.* (2005), Kartha and Larson (2000), DESA (2007), Ejigu (2008), Amigu *et al.* (2008), Painuly and Fenhann (2002), Dutschke *et al.* (2006) and the FAO Site Suitability Maps for rain-fed agriculture (www.fao.org/ag/agl/agll/cropsuit.asp).

problem in some areas, it is not a problem in others—for example, where the feedstock is grown on marginal land, such as *Jatropha* fencing. It is critical, therefore, to identify in advance where conflict between bio-energy crops and other land-uses is likely to occur, and to focus initial efforts on regions where policies are most likely to succeed (i.e. opportunities for high crop productivity with no land-use conflict).

- 2) **Resource competition.** Many bio-energy feedstocks have alternative uses in addition to bio-energy. Logs, branches, wood chips, bark and sawdust can be used in the paper industry or as construction materials. Cereal straws, maize stalks, bagasse and barbojo can be used as animal feed, soil conditioner, and roof thatching. Animal and human manure are important fertilizers. This means that bio-energy faces two-sided price competition: low bio-energy prices are needed to compete with fossil fuels, while high prices are needed to secure feedstock in a competitive market.
- 3) **Adequate demand.** While rural energy demand is rarely met in less developed countries, it is easy to oversupply. If heat and power are primarily desired for lighting and cooking, this can result in low load capacities, resulting in failed projects/enterprises. Bio-energy projects will be most likely to succeed where water pumps, small-scale manufacture/industry, lighting for schools/clinics and other electricity/shaft uses currently met by diesel can provide adequate load capacity to maintain financial viability.
- 4) **Unsuited sites.** For two of the most important bio-energy crops, sugarcane (the feedstock of the most developed bio-energy programme in the world) and oil palm (the most productive source of biodiesel), sub-Saharan Africa is largely unsuitable—and the regions where it is most suitable are the continent’s largest remaining tropical rainforests, where it would be inappropriate to increase forest clearing for agriculture. While the situation is better for soy and *Jatropha*, the relatively low rainfall of much of SSA results in low productivity agriculture. This is problematic given that the key to a profitable Brazilian ethanol programme is its sugar cane productivity (feedstock supply account for approximately 60% of total costs).
- 5) **Management capacity.** Many small-scale bio-energy projects have been attempted throughout SSA in recent decades; few are still in operation. A common thread running through these failures has been weak management capacity. That is, poor construction, incorrect operation, inadequate maintenance, poorly designed dissemination programmes, inadequate monitoring and low ownership responsibility are common.

It is not only from the bio-energy experience itself that lessons can be drawn. A number of important barriers to the development of bio-energy technology can be identified with reference to other policy contexts heavily dependent on focused policy for their promotion.²⁴ These barriers include:

- 1) A temporal gulf exists between government funding to encourage the commercialization of a socially beneficial technology and private sector funding for the same technology. This occurs when government programmes begin disengaging from funding so as to avoid

²⁴ These barriers were first identified in World Bank Working Paper No. 138 ‘Accelerating Clean Energy Technology Research, Development, and Deployment’, (Avato and Coony, 2008).

“picking winners” and subsidizing the industry, while the private sector has yet to develop confidence in the long-term profitability of the technology. This is especially the case with technologies associated with public goods.

- 2) There are high and increasing costs associated with developing the first conceptual plant, the first pilot plant and the first commercial plant for large-scale bio-energy development. After this stage of sectoral development, costs steadily decrease. Focused policies must be in place that will encourage the private sector to invest in spite of these initial and increasing costs.
- 3) There is little incentive for investors to engage in the risk associated with renewable energy (RE) development in Africa when there are alternative, lower risk opportunities available elsewhere. As a result, research into Africa’s technology needs lacks the necessary financial impetus to bear significant fruit. Table 7-5 shows the per capita investment in RE for selected countries and regions, comprising ~72% of the world’s population. There appear to be three distinct investment regions: the US and Europe (~50 US\$/capita), China, India and Latin America (2-3 US\$/capita) and Africa (0.10 US\$/capita). This investment barrier must be considered one of the biggest facing biomass energy in Africa.

Table 7-5: Global investment in RE by type and region (millions of US\$, 2006)

Investment	United States	EU 27	L. America	India	China	Africa
Venture Capital / Private Equity	\$4 862	\$1 814	\$0	\$197	\$765	\$0
Public Markets	\$3 449	\$5 667	\$185	\$0	\$560	\$0
Assets Financing	\$8 002	\$15 591	\$1 448	\$2 073	\$2 636	\$99
Total	\$16 277	\$23 072	\$1 633	\$2 270	\$3 961	\$99
USD per capita	\$53.57	\$46.23	\$2.87	\$1.98	\$2.98	\$0.10

Modified from Avato and Coony (2008)

With these barriers to overcome, and the drivers of bio-energy technology indirect at best, well-crafted policies will be necessary to catalyze bio-energy in Africa. The following section reviews the policies enacted in the EU, USA and elsewhere and evaluates their performance to offer guidance for similar programmes in Africa.

7.5. WHAT POLICY FRAMEWORKS ARE SUPPORTIVE OF BIOMASS ENERGY GENERATION?

While many distinct bio-energy policies have been promoted in recent decades, they can be usefully grouped under the following headings: financial incentives, research and entrepreneurial development, power purchase liberalization and demonstration projects. In this section, each of these policy supports will be discussed in turn with specific examples.

7.5.1. FINANCIAL INCENTIVES

The role of financial incentives (taxes and subsidies) is probably the most widely studied set of tools to promote bio-energy commercialization. These incentives can take several forms, but they each either increase the price of competing energy sources, or reduce the cost of bio-energy supply.

Reducing the costs of bio-energy can take several forms and does not necessarily involve a direct payment to a bio-energy producer or supplier: requiring (or encouraging) consumers to purchase a certain proportion of their domestic power from a bio-energy source (green certificates) is a form of subsidy, in that it reduces the risk of producing bio-energy (and thereby its cost) by providing a guaranteed market (Gan *et al.* 2007).

The most common financial incentive programmes are the following: feed-in tariffs (FITs), green certificates, tender schemes, blending requirements and differentiated taxes. It is worth noting that most countries (in the EU at least) tend to focus their bio-energy-encouraging policies on a single one of these options, although some run multiple programmes simultaneously. This simplicity of framework is important insofar as it contributes to a transparent, easy to understand bio-energy programme.

Furthermore, the unique geography, history and planning cultures of different states contributes to the choice of instrument they are most likely to use, as well as to how effectively it will be employed. For instance, the Netherlands and UK have abundant oil and gas resources, and have correspondingly less ambitious bio-energy programmes, while Portugal and Spain are dependent on fossil fuel imports, and thus have more ambitious bio-energy programmes. Similarly, the Greek planning culture has slowed the adoption of RE: more than 35 public sector institutions at multiple levels of government are needed to install a new electricity generating facility, which must be in compliance with 4 national laws and 7 ministerial decrees before it can be approved (Reiche and Bechberger 2004).

FEED-IN TARIFFS

A feed-in tariff is simply a guaranteed price over a predetermined length of time to bio-energy producers who sell electricity into the grid. It is the most popular financial measure to encourage bio-energy in the EU—and also the most successful at increasing the production of bio-energy (Lesser and Su 2008). By offering a guaranteed price (high enough to ensure profitability of the project) over a long period of time (assuring investors of the stability of their investment), this subsidy has resulted in significant increase in RE in, for instance, Germany and Spain. In the German case, biogas-generated power compensation is differentiated depending to the nature of the installation: 11.5 Eurocents/kWh for “standard” biogas energy and 19.5 Eurocents/kWh if it is generated by combined heat and power. These prices are guaranteed up to 2020 (Forster *et al.* 2008).

While FITs have generally been the most successful financial measure employed, use of a FIT does not in itself ensure success. For instance, both Greece and Spain employ FITs of a similar value and duration, but the Greek programme has performed poorly because of its high administrative hurdles, a strong Not-In-My-Backyard (NIMBY) sentiment and an inflexible transmission grid (Reiche and Bechberger 2004).

FITs are most successful when they are accompanied by direct subsidies to biomass energy generators: Germany makes payments of 60 €/kW for high-efficiency biomass heat generation, while Austria directly subsidizes 20-40% of total investment costs for new biomass installations (Ballard-Tremeer 2007) in addition to the FITs. This provides a strong incentive encouraging new bio-energy installations, and is particularly effective at mobilizing private-sector investment (Gan *et al.* 2007).

FITs are not without controversy, however, as the effectiveness of Germany’s FITs is largely the result of how large they are: such a large subsidy is a drain on the Treasury, which has prompted resistance from utilities and consumers because of the resultant higher electricity rates.

It is important that the size of the FIT be large enough to ensure long-term stability for investors, but not so large as to encourage inefficiency. The Public Utility Regulatory Policies Act (PURPA) in

California included a FIT to encourage RE that was large enough that it resulted in so-called “PURPA machines” which were so inefficient that they could only stay in operation because of the large subsidies (Bird et al. 2005; Lesser and Su 2008).

As a result, FITs require a well-monitored, transparent public utility/responsible agency to ensure that the programme is not being abused. While an effective tool, FITs are expensive and assume the existence of an existing, functional, energy distribution network. As such they may be only applicable in larger African states with well-funded treasuries and abundant opportunities for large-scale bio-energy generation (e.g. a pre-existing high-volume sugarcane or forest products industry).

GREEN CERTIFICATES

Green certification is the practice of requiring consumers (either utility, corporate or household) to purchase a certain portion of their power supply from certified “green” sources. This not only provides a guaranteed market for bio-energy (assuming it is included amongst the green certified energy sources) but also promotes an auditing programme that encourages efficiency from bio-energy-generating entities that may be receiving some other form of subsidy as well (and thus have fewer incentives to be efficient). Such programmes also maintain a sense of market competition (sales are guaranteed, not price) encouraging cost-effectiveness, as well as being naturally transparent (Gan *et al.* 2007).

The most developed green certificate programme in the EU is that of Sweden. Sweden’s 2004 green certificate requirement was that 8.1% of energy consumption should be from RE sources, which is being increased to 16.9% in 2010 (Balard-Tremeer 2007). However, green certificates fail to provide the same level of investment security as FITs, and can (as in the Swedish case) result in high administrative costs (Gan *et al.* 2007). Furthermore, given Sweden’s large available feedstock (due to its extensive timber and pulp industry), it is questionable whether the programme would be as successful elsewhere. As in the case of FITs, such a programme assumes the presence of a pre-existing, effective, competitive energy supply system—which is absent in most African states.

TENDER SCHEMES

Tender schemes are means to guarantee markets for bio-energy while promoting competition and (thereby) efficiency. In the case of the Non-Fossil Fuel Obligation (NFFO) in the UK in the early 1990s, a certain volume of required energy from RE was announced in advance, and project proponents were invited to bid (via project proposals including costs) to fulfill that quota. Projects were selected that minimized cost (Less and Su 2008). The Brazilian Alternative Energy Sources Programme (PROINFA) contains two phases, the first of which consists of FITs and the second a tender scheme (Dutra and Szklo 2008).

Such programmes promote efficiency and offer long-term stability while avoiding direct competition in production, but in the case of both the NFFO and PROINFA, the tender scheme failed to attract enough bids, and failed to have enough accepted bids fulfilled, to meet programme goals. In the case of the NFFO, this resulted in its abandonment (and replacement by a green certificate scheme) while PROINFA was heavily modified. In spite of this poor performance in the EU and Brazilian context, tender schemes may be an appropriate model in several African states where the ambition of the programme may not necessarily be to attain a certain proportion of national energy supply from bio-energy, but, rather, to provide incentives for the private sector to establish viable pilot projects in high potential locations.

BLENDING REQUIREMENTS

While many would not think of blending requirements (that is, a nationally-mandated blend of ethanol in gasoline) as a financial incentive, it is insofar as blending creates a guaranteed market for bio-energy producers, and thereby lowers investment risk (and cost) (De La Torre Ugarte 2006).

Blending requirements exist throughout the world, including Brazil, the EU, Ethiopia, Zimbabwe and Mozambique (De Castro 2007; Painuly and Fenhann 2002; UNCTAD 2006). While blending requirements can, if enforced, relatively easily create a market for ethanol and/or biodiesel, they often face opposition from the fossil fuel supply industry, which in the absence of a strong, independent public sector, can result in project failure (such as the state-of-the-art FINCHAA sugar mill in Ethiopia) (De Castro 2007). Furthermore, blending requirements require a consistent government commitment—when government support for blending waned in Zimbabwe in the late-1990s, its formerly successful biofuel industry shifted to exporting ethanol as a solvent (Amigun *et al.* 2008). Another weakness of blending requirements is that they do not necessarily entail domestic bio-energy production: acrimonious public debate about the importation of low-cost Brazilian ethanol to meet blending requirements has occurred in recent years in the EU (Henniges & Zeddies 2006).

DIFFERENTIAL TAXATION

A combination of increased taxes on fossil fuels and reduced taxes on bio-energy can be a very effective means to provide financial incentives to encourage bio-energy development, in particular as a supplement to other programmes. This has a long history in the EU.

In Finland, taxes on carbon dioxide emissions from fossil fuel consumption have been primarily responsible for a significant shift to wood combustion for electricity and heat generation. This has been accompanied by a direct subsidy for the management of public forests for energy generation (Ballard-Tremeer 2007). In France, ethanol receives a tax exemption of €0.50 /litre and biodiesel €0.35 /litre. In the US, ethanol receives a subsidy of \$0.51/gallon (Amigun *et al.* 2008). Targeted energy taxes have existed in Sweden since the 1950s, and currently cover general electricity consumption, using fossil fuels for heat production, and emissions of carbon dioxide, and oxides of sulphur and nitrogen (Karlsson and Gustavsson 2003). These taxes (coupled with Sweden's green certificate programme) have been cited as a primary reason for that country's success in promoting RE (Ballard-Tremeer 2007).

An EU-wide goal to increase the share of ethanol and biodiesel of total transport fuel from 2% in 2006 to 5.75% in 2010 is being promoted by most (11) members through differentiated taxation (Henniges & Zeddies 2006). Many of these tax incentives are viewed as temporary, to encourage production until the point at which economies of scale akin to the fossil fuel industry develop such that bio-energy can compete on equal footing (Moreira 2006). In the US, gasoline taxes accompanied by tax reductions on blended ethanol encourage bio-energy development, but benefits are primarily captured by the non-poor (since the poor do not consume much gasoline) (UN Energy 2007). Differential taxation is a very effective means of encouraging bio-energy, key is the existence of an adequate tax differential to encourage both an increase in bio-energy production and consumption, as well as an independent public service that can resist pressures by the fossil fuel industry lobbying against such a move. In African contexts, consumption taxes are likely to be less politically acceptable than production incentives—though these, too, may be difficult to absorb for low-revenue treasuries.

7.5.2. RESEARCH AND ENTREPRENEURIAL DEVELOPMENT

In addition to basic financial incentives, policies to promote bio-energy are usefully complemented by stimulating research and entrepreneurial development. Since many bio-energy technologies are unproven and underdeveloped, the improved performance that can only come by intentional experimentation is necessary to both promote cost efficiency and increase awareness of the opportunities bio-energy affords.

RESEARCH AND DEVELOPMENT (R&D)

While bio-energy offers a significant opportunity to promote energy security, environmental integrity and rural livelihoods, relative to fossil fuel resources it is currently competitive in few regions, such as Brazil. However, the Brazilian experience is encouraging: for many years Brazilian ethanol programmes were not competitive, but, as the technology developed, it came to represent a valuable cost saving for the nation—particularly in terms of avoided fossil fuel import costs. This suggests that it is only a matter of time and investment before bio-energy can become competitive with fossil fuels in other parts of the world.

Other, similarly hopeful programmes with only medium-term opportunities for profitability have made good use of R&D, the most notable being the Consultative Group on International Agriculture Research (CGIAR), potentially the most successful piece of targeted R&D policy in history. CGIAR's ultimate goal of increasing food supply was met through high investments from the Ford and Rockefeller Foundations as well as the World Bank and other donors, eventually reaching US\$ 460 million in annual funding. Critical to CGIAR's success was its regional research centres in key developing countries, focused on improving yields from certain local food crops (Avato and Coony 2008).

While similar programmes exist for bio-energy, their scope is far less ambitious: the total annual investment by GEF in its Climate Change Focal Area (which includes bio-energy funding) is ~US\$ 220 million. This amount is further divided into improved efficiency fossil fuel energy, non-bio-energy RE, and a host of adaptation projects. Furthermore, this funding is not focused on R&D, but rather on project establishment (GEF 2007).

The R&D funding necessary to develop bio-energy resources for the poor (particularly in Africa) has yet to be realized. Though R&D for RE and energy efficiency (public and private) stood at approximately US\$ 16.3 billion in 2006, an internationally funded regionally-focused R&D institution has yet to appear for bio-energy, although the recent announcements by the UK on the formation of the International Environmental Transformation Fund have some promise in this regard (Avato & Coony 2008). On a domestic scale, revenue from FITs or energy taxes has been funnelled into R&D for bio-energy by 9 EU members—but given the spatially variable nature of bio-energy resources, most effective R&D for Africa must come from research done within Africa (Gan *et al.* 2007; Henniges & Zeddies 2006).

ENTREPRENEURIAL DEVELOPMENT

In addition to promoting R&D to improve efficiency while providing direct financial incentives, both of which encourage the private sector, policies that focus directly on entrepreneurial development are important in achieving the same goal. Entrepreneurs can also be important in stimulating corresponding reforms in government policies (Hillman *et al.* 2008). Kartha *et al.* (2005) have described several means by which governments can encourage entrepreneurial development, including:

- Replicating successful projects in high-exposure areas

- Identifying key potential markets
- Providing direct training to high-potential candidates
- Streamlining and facilitating registration, permit and licensing procedures
- Monitoring early commercialization to ensure quality control
- Promoting consumer awareness
- Creating partnerships with financial institutions to improve access to finance
- Promoting institutions (such as co-operatives) to manage and reduce risk
- Disseminating information to potential entrepreneurs that is scarce or difficult to access, including contacts, lessons-learned, technical data, meteorological data, information on energy crops, management practices and legal regulations

Joint ventures between state governments and private companies can also bear significant fruit, such as a government-facilitated partnership of Saxlund (a Swedish company) with a series of small firms in the Baltic states to jointly manufacture feedstock-handling equipment and finance for bio-energy. Finally, such efforts must be proactive, seeking out potential entrepreneurs and actively promoting bio-energy, rather than passively waiting for entrepreneurs to request information.

7.5.3. POWER PURCHASE LIBERALIZATION

Traditional power supplying utilities and the fossil fuel industry tend to resist efforts to integrate new, decentralized energy sources into traditionally centralized, fossil fuel dominated grids. This is true regardless of geography, having been documented in China, Ethiopia and Germany, among others (World Bank 2005; De Castro 2007; Faulin *et al.* 2006).

Nonetheless, requiring utilities to purchase bio-energy-generated power, and/or requiring the blending of ethanol and biodiesel with fossil fuels, are critical elements to assuring an adequate demand for new bio-energy development. This is particularly the case for non-traditional energy suppliers, such as the forest products and sugarcane industries: the assurance that they will be able to sell excess capacity into the grid is a major incentive to upgrade their production processes—and has been an important step in the promotion of CHP in Brazil (Moreira, 2006). Furthermore, if a medium-term goal is rural electrification, the ability to sell power into an energy grid (if it exists) is critical for encouraging entrepreneurs in the face of low load capacities (Karthä *et al.* 2005).

Aside from basic legislative requirements, persuading traditionally influential utilities and corporations to accept these arrangements is primarily a question of political will—which may represent a potential impediment to adoption of bio-energy in Africa (Amigun *et al.* 2008). A Swedish bio-energy programme in which the public sector coordinated negotiations between fossil fuel companies and carmakers for the establishment of blending targets, standards and distribution networks to achieve specific environmental goals may be a worthwhile model—but again, the political will to ensure that such procedures are participated in, and enforced, is necessary to ensure success.

7.5.4. DEMONSTRATION PROJECTS

The experience of bio-energy projects funded by UNDP-GEF under GEF Operational Programme 6 has underscored the importance of demonstration projects. Demonstration projects represent an opportunity to focus components of financial incentives, R&D, promoting entrepreneurship and bio-energy purchase obligations into a single effort that provides the learning and experience necessary

to create efficient, low-cost, mature industries staffed by capable individuals. The experience of UNDP-GEF demonstration projects has demonstrated the following 10 critical points:²⁵

- 1) The second generation of a development project is often much more cost-effective than its first iteration as a result of learning-by-doing. A phased approach to demonstration projects is therefore preferable to a single project.
- 2) Long-term investments (minimum 5 years) are necessary for all aspects of the bio-energy supply chain (feedstock, technology, support services) to develop.
- 3) While high-potential niche markets provide an important learning environment for the technology, selecting the correct market requires significant local knowledge and a certain amount of trial and error.
- 4) Capturing adequate feedstock supply from the local market is the most important risk to investment. Adequate supply must be assured as the first step in project development, in the knowledge that feedstock-supply complexity increases with the scale of the project. As a result, technologies that are feedstock-type flexible are the best performing.
- 5) The scale of energy demand in feasibility studies is invariably overestimated. When a risk of low load capacities exists, this must be taken into consideration before project approval.
- 6) Administrative barriers will take longer to address than expected. Long-term time investment in training government bodies responsible for all components of the licensing process, including legal expertise, are essential.
- 7) It is critical for large demonstration projects to be successful the first time—future markets will be restrained by failure. Local scepticism about bio-energy is likely to be high regardless, and must consistently be addressed through targeted information and awareness campaigns.
- 8) Focused training and skills-building activities of local engineers and politicians, particularly those including study tours of existing, successful facilities in similar contexts, are very effective. The development of technical expertise is one of the most important benefits of demonstration projects.
- 9) The start-up phase will take longer than anticipated, partly because feasibility studies will likely be superficial in nature. Upon approval, investments will have to be significantly redesigned. In particular, the price of inputs is usually underestimated. Competition in initial submissions is therefore important, especially in emerging markets. Significant flexibility on behalf of investors and managers will be necessary.
- 10) While often unavoidable, complex ownership and multiple financing sources will increase transaction costs and make project replication difficult while simultaneously requiring the employment of costly financial managers and legal advisers. Co-financing is usually identified without competition, which can create conflict of interest and decrease the likelihood of cost-effective projects. Building contractors, equipment suppliers and raw materials owners will be exposed to moral hazard since their goal may be to maximize the value of operating costs, rather than investment profitability.

While demonstration projects are crucial, they are difficult to complete successfully. The above points should inform any demonstration project planning in bio-energy.

²⁵ These points are compiled and summarized from recommendations given in the final report reviewing 5 UNDEP-GEF projects in Europe and the CIS (Ballard-Tremeer 2006).

7.5.5. CONCLUSIONS

While direct financial incentives, research and entrepreneurial development, power purchasing liberalization and demonstration projects are all important and complementary efforts to promote bio-energy, their application does not imply commercialization success. The unique geography, history and political environments of different states will either constrain or promote the effectiveness of these policies to respond to the barriers to bio-energy development (Kondili and Kaldellis 2007).

As a result, pursuing proven technologies that use available feedstock while minimizing administrative complexity must be the focus of any bio-energy promotion programme, particularly given the importance of “getting it right” the first time (FAO 2008). The political environment must be carefully scrutinized before any of these policy packages is promoted—experience demonstrates how easy it is for aspects beyond programme control, such as changes in local and national governments and fluctuations in international energy prices, to undermine the success of a bio-energy initiative (Ballard-Tremere 2006; Kartha *et al.* 2005).

The broader legislative environment is also critical, though it cannot be generalized from state (or region) to state. For example, a critical element in promoting adequate feedstock in the EU has been the reform of the Common Agricultural Policy (CAP) to allow farmers to grow bio-energy crops on set-asides for which they already receive subsidies, significantly increasing the opportunities for farmers to generate income (Forster *et al.* 2008; Henniges & Zeddies 2006).

Significant success is possible. The Region of Navarre in Spain embarked on an ambitious energy reform effort in 1995 with a comprehensive policy package to encourage RE. The regional government’s policies included FITs for the technologies with the most potential, direct subsidies (20-30 % of gross investment) in addition to €400 million in infrastructure upgrades. It was accompanied by public investment in RE firms and consistent, targeted information campaigns to overcome initial public resistance, including basing policies on a specially designed survey of public RE values. Finally, support from the monopoly energy company was sought and received early in the process. Ten years later, 60% of total electricity consumption in the region is sourced from RE (Faulin *et al.* 2006).

Such success is possible elsewhere, but without crafting these policies in a similarly focused manner around local realities, the prospects for encouraging bio-energy development are poor.

7.6. WHAT CAPITAL AND FINANCING OPTIONS FOR BIOMASS ENERGY EXIST IN AFRICA?

Financing programmes to promote bio-energy is a difficult task given its current marginal profitability in much of the world. This is especially the case in Africa, particularly because of the relatively large up-front capital costs required (Kartha *et al.* 2005). In the European context, much of the start-up funds for new bio-energy projects have been sought through co-financing between government, international organizations (such as the GEF) and private investors—and even in this relatively capital rich environment, acquiring adequate finance has been a major challenge (Ballard-Tremere 2007). Within a CDM in Africa context, a number of options are available, including self-financing, international funding agencies and microcredit.

7.6.1. AFRICAN CDM CONTEXT

With respect to the general CDM context, in 2007, primary transactions in the CDM resulted in transfers of US\$7.5 billion to developing countries, representing 551 MtCO₂e in avoided greenhouse gas emissions. Unfortunately, Africa has supplied only 5% of total CER sales, and less than 1% of the global total was sourced from forestry projects (Capoor and Ambrosi, 2008). Africa hosts only 87 CDM projects in total, and 55 are in South Africa, Egypt, Morocco and Kenya.²⁶

The low visibility of Africa in the CDM pipeline has been blamed on the complexity of CDM requirements, resulting in transaction costs that are simply too high to be overcome in Africa (Aune *et al.* 2005; Capoor and Ambrosi 2008; Jung 2005). The bare minimum necessary for projects in a given state to be registered is the existence of a functional Designated National Authority (DNA), but even this is beyond the institutional capacity of many African governments (Jindal *et al.* 2008).

However, bio-energy in general has been one of the most successful project types globally, accounting for 21% of projects in the pipeline, 9% of CERs/year and 6% of issued CERs (the third largest volume of issued CERs, behind N₂O and HFC projects). Out of Africa's 30 registered projects (of which 22 are in South Africa, Egypt and Morocco), 5 are bio-energy. While this offers hope for the ability of the CDM to fund bio-energy projects in Africa, current success is focused in the most affluent states with the best administrative capacity. Nonetheless, CER revenue may be adequate to supply funding for an FIT, as has been suggested elsewhere, for instance, Thailand.

Other means of promoting CDM activities in Africa, such as reducing transaction costs through simplified modalities and procedures, have yet to make an impact, and have not increased the volume in the project pipeline (Jindal *et al.* 2008). Programmatic options (that is, involving generic changes to rules and incentives as opposed to the project-based approach) have some promise, in that they respond to several current weaknesses in the CDM approach by opening areas to activities that would otherwise be excluded, resisting the "projectization" of carbon management (which implies suspension of normal politics, social life and economics temporally and spatially and is therefore inherently unsustainable), and thereby offering more opportunities for both synergy with broader development actions and permanent increases in carbon at a regional scale, rather than over only a few thousand hectares (van Noordwijk *et al.* 2008). At the same time, however, a programmatic approach is even more dependent on well-functioning government institutions. Given the significant African experience with bio-energy projects and the relative success of bio-energy project types globally and in Africa, CER revenue holds much more promise for funding bio-energy projects than other project types, such as afforestation.

7.6.2. SELF-FINANCING

Differentiated taxes and user fees have been used throughout Europe to fund FITs, R&D and other incentives to promote bio-energy. Unfortunately, given generally low electricity access and metering in many African countries, this option will only be weakly applicable. In South Africa, a new system of FITs has recently been proposed to encourage certain RE technologies, including some bio-energy technologies. However, given South Africa's status as the most affluent large state in SSA, whether other states could maintain their own FITs is questionable. Supplementary funding from outside individual states is likely to be necessary. Nonetheless, the perceived complexity of CDM projects can be greatly reduced if the project, through sales of its carbon assets, can finance itself.

²⁶ www.cdmpipeline.org, December 2008

7.6.3. INTERNATIONAL FUNDING AGENCIES

Given the high volume of funding available from the GEF and its experience with bio-energy projects in Egypt, Poland, Slovenia, Latvia, Belarus, Mauritius and elsewhere, it seems like a natural fit (Ballard-Tremeer 2007; GEF 2007). However, while GEF funds are available, they are not enough to even approach the amount of support necessary to achieve a significant global development of bio-energy (Ballard-Tremeer 2007). The World Bank, US Department of Energy, the Netherlands and UNDP have pooled resources into the Financing Energy Services for Small-scale End-users (FINESSE) programme, which has recently started to commission reports and make small investments in South Africa through the African Development Bank (ADB). Though the scope of FINESSE and the ADB is not targeted solely at bio-energy, for individual projects it will be a useful source of international investment.

However, for ambitions greater than the project scale, a new funding agency akin to CGIAR in scope and mandate but focused on developing bio-energy through regional research centers and locally appropriate technologies may be necessary if Africa's bio-energy potential is to be fulfilled. While this would add another layer of bureaucracy, the potential for such an agency over time to standardize CDM bio-energy project operation is significant.

7.6.4. MICROCREDIT

While there is a broad literature on microcredit in general, there is very little that has been applied to the use of microcredit to encourage small-scale bio-energy. One important example is its use in Nepal as the centerpiece of USAID's Nepal Biogas Microfinance Capacity Building Programme. This project has resulted in the construction of over 600 household-size biogas plants through microcredit. Given the potential for small-scale biogas in parts of Africa, such a programme should be considered very carefully as a template.

7.6.5. OPPORTUNITIES FOR CDM FINANCING

While the general weakness of the CDM in providing funding for climate change mitigation projects in Africa must, and has been, acknowledged, it needs also be recognized that the potential of the CDM for bio-energy projects is much higher than other forms. Given the many successful projects in other tropical regions, when a strategic approach to project development is pursued, in an environment of adequate institutional capacity to respond to the barriers for creating a facilitating policy environment, there is no compelling reason why CDM bio-energy projects should not be successful in a variety of African contexts. However, note that the barriers to the creation of a facilitating policy environment (such as land and resource competition, adequate demand, unsuitable sites and management capacity) must be addressed before a given project will have any hope of success: CDM funding is not a panacea for these problems—profitability is only one barrier standing in the way of a successful bio-energy project.

7.7. CONCLUSIONS

This chapter has examined the contexts and means whereby biomass energy may be catalyzed in Africa. Specifically, it has shown that diverse prospects exist for the basic bio-energy technologies of direct combustion of forest and agricultural products and residues, pyrolysis, gasification, anaerobic digestion, alcoholic fermentation and mechanical conversion of oil-seeds.

While in other parts of the world energy security and climate change mitigation have been (and are) important drivers, in Africa concerns of energy delivery, industrial efficiency and sanitation are pre-eminent. Context-specific policies will need to be designed to overcome the host of barriers bio-energy development faces in Africa, particularly (though not limited to) opposition from vested interests associated with fossil fuels, up-front costs, supply chain complexity, competition for land and resources, inadequate demand, relatively rare suitable sites, low management capacity and a paucity of available investment and research funds.

Policy options including financial incentives (FITs, green certificates, tender schemes, blending requirements and differential taxation), research and entrepreneurial development, power purchase liberalization and demonstration projects will all help to overcome these obstacles, funded either through self-financing, the CDM, international donors or microcredit. However, given the wide array of options, and the importance of establishing early success in order to garner and maintain public support, a strategic approach is clearly appropriate.

The following checklist can be used as a basis for a strategic approach to developing a bio-energy programme:

- 1) Identify areas of abundant feedstock available at low- or no-cost and for which little or no competition in land or use exists. Bio-energy must begin where it has the most opportunity for success: experience shows that local, adequate, low-cost feedstock is the single-greatest determinant of success.
- 2) Select a single technology upon which to focus, dependent upon the feedstock identified. In the case of well-established forest products, sugarcane or brewing industries, some combination of large-scale combustion of residues, gasification or alcoholic fermentation is suggested. High consumption of charcoal from unregulated public forests, or by a large industrial consumer, may represent an opportunity to develop more efficient charcoal production. Sanitation concerns surrounding animal husbandry, sewage treatment, household human waste, hospitals and abattoirs suggest opportunities for anaerobic digestion at a variety of scales. An abundance of degraded or marginal farmland in rural regions unconnected to the energy grid provide opportunities for biodiesel. Regardless, feedstock should determine technology, not *vice versa*.
- 3) At this point, the scale of project and technology type will determine the scope of succeeding steps. If large-scale industrial action is pursued, steps must be taken to liberalize power purchasing and political will must be exerted to ensure acceptance by monopolistic utilities and fossil fuel suppliers. Legislative reform that redresses advantages to fossil fuels, or establishes FITs or green-certificate-like purchasing quotas may be developed depending on Treasury restraints. Particularly for the first installation, direct subsidies and tax incentives may be necessary. Learning tours for industry leaders, managers and engineers of established, well-functioning facilities is highly recommended. In the case of a demonstration project, competitive bidding in the feasibility study stages is advisable – tender schemes may help in this regard. The opportunities to capture supplementary revenues through the carbon finance market should be pursued.
- 4) For small-scale actions that will not be selling into the energy grid, less legislative reform is required. Entrepreneurial training becomes more important, as does attracting the interest of a well-qualified NGO to capture international funding and training. Emphasis should be placed on learning-by-doing and eventual scaling up through developing a market and

domestic production of the particular technology. Learning tours for local entrepreneurs and community leaders of successful project sites remains important.

- 5) Regardless of scale, financing should be kept as simple as possible. Project management needs to be flexible, and institutional restraints deriving from complicated fund arrangements have been known to negatively affect bio-energy projects.
- 6) Careful monitoring of financial performance, legislative restraints, maintenance, community support, trends in international energy prices and, in particular, ongoing feedstock availability must be given a high priority. These all change with time and politics, and long-term success will depend upon them.

While this approach is hardly exhaustive, it highlights the key steps that must be made for developing any bio-energy programme.

Furthermore, the definition of “success” must be questioned at every step: project success for a government official, contractor, engineer, community leader and local entrepreneur will mean very different things. This tension will require a balancing of interests by project designers and managers. However, given that bio-energy offers the potential of a stable, secure locally-derived energy source with a host of social and environmental benefits, the opportunity, though complex, is surely worth pursuing.

7.8. REFERENCES

- Amigun, B., Sigamoney, R. and von Blottnitz, H. (2008) Commercialisation of biofuel industry in Africa: a review. *Renewable and Sustainable Energy Reviews* 12: 690-711.
- Andersen, P.D., Christensen, J. and Kossmann, J. (2003) Emerging and future bio-energy technologies. In *Riso Energy Report 2: New and Emerging Bio-energy Technologies*. Larsen, H., Kossmann, J. and Sonderberg Petersen, L. (eds). *Riso-R-1430 (EN)*: 18-22.
- Andersson, G., Asikainen, A., Bjorheden, R., Hall, P., Hudson, J., Jirjis, R., Mead, D., Nurmi, J. and Weetman, G. (2002) Production of forest energy. In *Bio-energy from Sustainable Forestry: Guiding Principles and Practice*. Richardson, J., Bjorheden, R., Hakkila, P., Lowe, A. and Smith, C. T. (eds). London: Kluwer.
- Aune, J., Alemu, A., Gautam, K. (2005) Carbon sequestration in rural communities: is it worth the effort? *Journal of Sustainable Forestry* 21(1): 69-79.
- Avato, P. and Coony, J. (2008) Accelerating clean energy technology research, development and deployment: lessons from non-energy sectors. *World Bank Working Paper No. 138*. Washington DC: World Bank.
- Ballard-Tremere, G. (2007) *Opportunities for Biomass Energy Programmes: Experiences & Lessons Learned by UNDP in Europe & the CIS*. London: Ecoharmony.com.
- Bandyopadhyay, S., Shyamsundar, P and Baccini, A. (2006) Draft background paper for the Malawi poverty assessment. *World Bank Policy Research Working Paper*, 4068.
- Best, G., Christensen, J. (2003) Role of biomass in global energy supply,” In *Riso Energy Report 2: New and Emerging Bio-energy Technologies*. Larsen, H., Kossmann, J. and Sonderberg Petersen, L. (eds). *Riso-R-1430 (EN)*: 8-12.
- Bird, L., Bolinger, M., Gagliano, T., Wiser, R., Brown, M. and Parsons, B. (2005) Policies and market factors driving wind power development in the United States. *Energy Policy* 33: 1397-1407.
- Bridgwater, T. (2006) Review: Biomass for energy. *Journal of the Science of Food and Agriculture* 86: 1755-1768.
- Capoor, K. and Ambrosi, P. (2008). *State and Trends of the Carbon Market 2008*. Washington, DC. World Bank.
- Charles, M., Ryan, R., Ryan, N. and Oloruntoba, R. (2007) Public policy and biofuels: the way forward? *Energy Policy* 35: 5737-5746.

- Chynoweth, D., Owens, J. and Legrand, R. (2001) Renewable methane from anaerobic digestion of biomass. *Renewable Energy* 22: 1-8.
- Clean Development Mechanism (2006) *Mitigation of Methane Emissions in the Charcoal Production of Plantar, Brazil, Version 3 (Project Design Document Version 3)*. Bonn: UNFCCC.
- Collier, P., Conway, G. and Venables, T. (2008) Climate change and Africa. *Oxford Review of Economic Policy* 24: 337-353.
- Czernik, S. and Bridgwater, V. (2004). Overview of applications of biomass fast pyrolysis oil. *Energy & Fuels* 18: 590-598.
- de Castro (2007) *Biofuels: An Overview*. Prepared for: Mission for the Environment and Forestry Department of the Netherlands, Ministry of Foreign Affairs. Amsterdam.
- de la Torre Ugarte, D. (2006) Developing bio-energy: Economic and social issues. *Bio-energy and Agriculture: Promises and Challenges* 14: Brief 2.
- Department of Economic and Social Affairs. (2007) Small-scale production and use of liquid biofuels in Sub-Saharan Africa: Perspectives for sustainable development. *Background Paper*, No. 2, DESA/DSD/2007/2. New York: UN DESA.
- Dutra, R. and Szklo, A. (2008) Incentive policies for promoting wind power production in Brazil: scenarios for the Alternative Energy Sources Incentive Program (PROINFA) under the new Brazilian electric power sector regulation. *Renewable Energy* 33: 65-76.
- Dutschke, M., Kapp, G., Lehmann, A. and Schafer, V. (2006) Risks and chances of combined forestry and biomass projects under the Clean Development Mechanism. *CD4CDM Working Paper Series*, Working Paper No. 1. Roskilde: UNEP-Risoe Centre.
- Ejigu, M. (2008) Toward energy and livelihoods security in Africa: Smallholder production and processing of bio-energy as a strategy. *Natural Resources Forum* 32: 152-162.
- European Union. (2005) *Biomass Action Plan*. Commission of the European Communities 2005, Communication from the Commission. Brussels.
- Faulin, J., Lera, F., Pintor, J. and Garcia, J. (2006) The outlook for renewable energy in Navarre: an economic profile. *Energy Policy* 34: 2201-2216.
- Food and Agriculture Organization (2008) Forests and energy: key issues. *FAO Forestry Paper* 154.
- Forster, M., Helms, Y., Herberg, A., Koppen, A., Kunzmann, K., Radtke, D., Ross, L. and Itzerott, S. (2008) A site-related suitability analysis for the production of biomass as a contribution to sustainable regional land-use. *Environmental Management* 41: 584-598.
- Gan, L., Eskeland, G. and Kolshus, H. (2007) Green electricity market development: lessons from Europe and the US. *Energy Policy* 35: 144-155.
- Global Environment Facility (2007) *Investing in Our Planet: GEF Annual Report 2006-07*. Washington, DC: GEF.
- Hillman, K., Suurs, R., Hekkert, M. and Sanden, B. (2008) Cumulative causation in biofuels development: a critical comparison of the Netherlands and Sweden. *Technology Analysis & Strategic Management* 20: 593-612.
- Henniges, O., Zeddies, J. (2006) Bio-energy in Europe: Experiences and prospects. *Bio-energy and Agriculture: Promises and Challenges* 14: Brief 9.
- Jindal, R., Swallow, B. and Kerr, J. (2008) Forestry-based carbon sequestration projects in Africa: potential benefits and challenges. *Natural Resources Forum* 32: 116-130.
- Jung, M. (2005) The role of forestry projects in the Clean Development Mechanism. *Environmental Science & Policy* 8: 87-104.
- Kammen, D. (2006) Bio-energy in developing countries: Experiences and prospects. *Bio-energy and Agriculture: Promises and Challenges* 14: Brief 10.
- Karekezi, S. and Kithyoma, W. (2006) Bio-energy and the poor. *Bio-energy and Agriculture: Promises and Challenges* 14: Brief 11.
- Kartha, S. and Larson, E. (2000) *Bio-energy Primer: Modernised Biomass Energy for Sustainable Development*. New York: UNDP.
- Kartha, S., Leach, G. and Rajan, S. (2005) Advancing bio-energy for sustainable development: Guideline for policymakers and investors. Energy Sector Management Assistance Programme, *World Bank Report*, 300/05..
- Kondili, E. and Kaldellis, J. (2007) Biofuel implementation in East Europe: Current status and future prospects. *Renewable and Sustainable Energy Reviews* 11: 2137-2151.
- Lavalin (2007) Strategic/Sectoral, Social and Environmental Assessment of Power Development Options in the Nile Equatorial Lakes Region: Montreal: SNC-Lavalin International.

- Lesser, J. and Su, X. (2008) Design of an economically efficient feed-in tariff structure for renewable energy development. *Energy Policy* 36: 981-990.
- Moreira, J. (2006) Brazil's experience with bio-energy. *Bio-energy and Agriculture: Promises and Challenges* 14: Brief 8.
- Palaez-Samaniego, M., Garcia-Perez, M., Cortez, L., Rosillo-Calle, F. And Mesa, J. (2008) Improvements of Brazilian carbonization industry as part of the creation of a global biomass economy. *Renewable and Sustainable Energy Reviews* 12: 1063-1086.
- Painuly, J. and Fenhann (2002) *Implementation of Renewable Energy Technologies: Opportunities and Barriers. Summary of Country Studies*. Roskilde: UNEP-Risoes Centre.
- Reiche, D. and Bechberger, M. (2004) Policy differences in the promotion of renewable energies in the EU member states. *Energy Policy* 32: 843-849.
- United Nations Conference on Trade and Development (2006). *The Emerging Biofuels Market: Regulatory, Trade and Development Implications (UN Doc: UNCTAD/DITC/TED/2006/4)*. Geneva: UNCTAD.
- United Nations Development Programme (2007) *A Review of Energy in National MDG Reports*. New York: UNDP.
- United Nations – Energy (2007) *Sustainable Bio-energy: A Framework for Decision Makers*. New York: UN-Energy.
- Von Braun, J., Ahmed, A., Asenso-Okyere, K., Fan, S., Gulati, A., Hoddinott, J., Pandya-Lorch, R., Rosegrant, M., Ruel, M., Torero, M., van Rheenen, T. and von Grebmer, K. (2008) High food prices: the what, who and how of proposed policy actions. *International Food Policy Research Institute, May Policy Brief*. Washington, DC: IFPRI.
- Woods, J. (2006) Science and technology options for harnessing bio-energy's potential. *Bio-energy and Agriculture: Promises and Challenges* 14: Brief 6.
- World Bank (2005) Scoping study of biomass energy development in Inner Mongolia, China. *Asia Alternative Energy*. Washington, DC: World Bank.
- Yan, L. and Yin, X. (2008) Technical solutions to biomass energy projects in Africa. ECOWAS Bank for Investment and Development Working Paper.

8. EVALUATING ANAEROBIC DIGESTER ENERGY GENERATION: OPPORTUNITIES AND BARRIERS

By Stephen Karekezi, Waeni Kithyoma and Oscar Onguru

Energy, Environment and Development Network for Africa (AFREPREN/FWD)

Contact: afrepren@africaonline.co.ke

8.1. ABSTRACT

This chapter addresses anaerobic digestion-based biomass energy generation—often simply referred to as “biogas” production. The purpose of this chapter is to identify the opportunities and barriers associated with the technology in order to suggest promising approaches and policies for its promotion. The chapter assesses the technical, financial, regulatory and awareness barriers facing biogas technology and also recommends policy and financial instruments (including carbon finance) that have been used to stimulate investment in the technology. The study is not confined to Africa but ranges beyond the continent to garner global lessons on how broader use of biogas can be catalysed in Africa. Examples are included of successful implementation of biogas energy as well as the enabling conditions needed for its implementation. While the challenges in Africa are sizeable, the success of biogas in other regions suggests it is worthwhile pursuing.

8.2. INTRODUCTION

Biomass is a versatile energy source. It is one of the most common forms of energy used in the world today. In Africa, where it constitutes 70-90% of energy used, the main sources of biomass include trees, timber waste, agricultural residues and human and animal wastes. With recent high oil prices (which have since experienced dramatic reductions, demonstrating once again the instability of fossil fuel prices) and environmental and financial incentives such as carbon finance beginning to take root, modern biomass energy options such as biogas are increasingly becoming economically attractive. Studies have shown that biogas has the potential to supply a significant part of African energy needs if effectively and sustainably harnessed.

Anaerobic digestion-based biomass energy generation (or biogas energy) is a promising energy option in Africa. The purpose of this paper is to identify the opportunities and barriers associated with the technology—with the aim of proposing environmentally and economically viable promotion approaches. The paper assesses the technical, financial, regulatory and awareness barriers facing the technology, and also recommends policy and financial instruments (including carbon finance) that have been, and could be, used to stimulate investment in the technology. The scope of the study is not confined to Africa but ranges beyond the continent to garner global lessons on how broader use of biogas can be catalysed in Africa. Examples are included of successful implementation of biogas energy from around the world, and the enabling conditions needed to effect its implementation.

8.2.1. DESCRIPTION OF THE TECHNOLOGY

Biogas is a combustible gas produced by the fermentation of organic materials in the absence of oxygen. It is composed of approximately 60% methane (CH₄) and 40% carbon dioxide (CO₂). It has an unpleasant smell and burns with a hot blue flame. It can be used in gas stoves and lamps, to run refrigerators, to generate electricity, and to power stationary diesel and petrol engines (Karekezi and Ranja 1997; ETC 2007).

Biogas has a calorific value of about 24 MJ/m³. It is estimated that 1 m³ of biogas can generate 1.5 KWh of electricity, and is equivalent to 0.54 l and 0.52 l of petrol and diesel respectively (Senadeera *et al.* 2007).

The production of biogas requires the use of carbohydrates, proteins or fats, or the soluble organic matter (volatile fatty acids, mainly acetic acids, amino acids, long-chain fatty acids, and organic sulphur and ammonium compounds). These materials are found in agricultural biomass and agro-processing residues, animal dung, food processing effluents, sewage, municipal waste and other organic waste streams (Karekezi and Ranja 1997; ETC 2007). Biogas can also be produced from a broad range of feedstocks that are suitable for anaerobic digestion. There are many potential energy crops, which may be suitable for biogas production, including sugarcane, sorghum and napier grass. Other fiber-rich waste such as wood and leaves are normally difficult to digest and make poor food for digesters (Electrigaz 2007). The best crops should have low fertility requirements, and low energy costs for planting and harvesting (Wilkie 2009).

INDUSTRIAL-SCALE BIOGAS

Large-scale or industrial-scale biogas production occurs in “digesters”, which can be divided into two principal groups: batch digesters and continuous flow digesters. The batch-type digesters are the simplest to build. Their operation consists of loading the digester with organic materials and allowing it to digest. The retention time depends on temperature and other factors. Once the digestion is complete, the digestate is then removed and replaced with a new batch of organic material. In a continuous flow digester, in contrast, organic material is constantly or regularly fed into the digester.

The material moves through the digester either mechanically or by the force of the new feed pushing out digested material. A moderate to large scale biogas digester has a volume of about 300 m³ and can yield as much as 20 m³ of gas per day (Electrigaz 2007).

The batch digester is the simplest technology to adopt on a large scale. The biogas digester plant is filled with substrate materials and is suitably inoculated to enable appropriate bacterial populations to predominate. At the completion of the digestion process, the material is removed and replaced with another batch. After the biogas is obtained, the slurry that remains in the digester (also known as digestate) can be used as compost manure. The bacteria in the digester operate under airtight conditions, transforming the organic material into biogas. The transformation process occurs in four steps. In the first step, hydrolysis breaks down the long chains of complex input material into smaller compounds. In the second step, the molecules are broken down further and produce by-products: simple fatty acids, carbon dioxide and hydrogen. These substances are transformed in the third step to the precursors of biogas. In the last step, methanogenesis, the biogas is finally produced, with a methane content of between 50 and 70 percent.

Once the biogas has been produced, it can be burned in a combined heat and power plant, as the primary fuel to produce electricity and process heat (ABO Wind 2007).

Figure 8-1 illustrates the entire process, from when the raw material is fed into the storage tank to the final stages when electricity is generated (Karekezi and Ranja 1997).

Figure 8-1: Flow diagram of a medium – large scale biogas plant

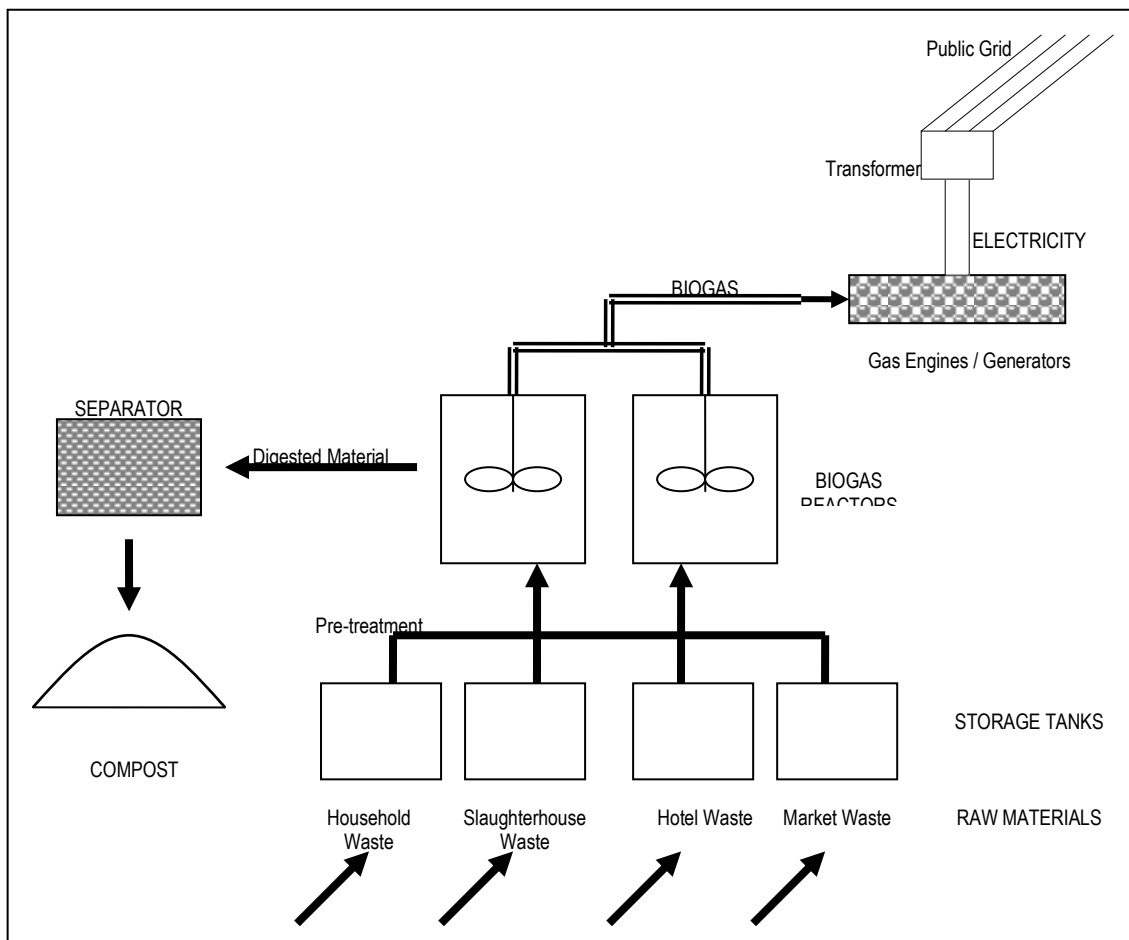

Source: Karekezi and Ranja (1997)

DOMESTIC AND INSTITUTIONAL BIOGAS SYSTEMS

Small-scale biogas plants are mostly found on family farms or in institutions such as schools and hospitals, and are the most common types of digester in Africa. The plants have digester volumes of between five and ten cubic metres, with a biogas output of 2-4 m³ per day, equivalent to between 40 and 80 MJ per day. They can be either batch or continuous flow models (Karekezi and Ranja 1997; ETC 2007).

There are many simple biogas plant designs. A domestic biogas unit consists of the following components:

- Mixing pit
- Inlet and outlet pipes
- Digester
- Gas-holder
- Gas pipes, valves and fittings
- Slurry store

In the mixing pit, water and the organic feed stock in question, which in most cases is usually animal dung, are mixed²⁷ to form a homogenous mixture (substrate). Any organic waste (e.g. human excreta, manure, animal slurry, fruit and vegetable waste, slaughter house waste, meat packing waste, dairy factory waste, brewery and distillery waste etc.), has the ability to produce biogas. But, as has already been mentioned, other fiber-rich waste such as wood, leaves, etc. are normally difficult to digest and should be removed from the mixture before the material is allowed to flow into the digester (Electrigaz 2007). The feed is led into the digester through the inlet and the digested substrate flows out through the outlet pipe. The digester of a biogas plant accommodates the substrate during the digestion process (bacterial activity) and is usually made of bricks and concrete. The substrate is broken down by bacterial activity, producing gas.

The process of gas production is similar to the one described earlier under "Industrial Scale Biogas". Anaerobic breakdown of waste occurs at temperatures lying between 0°C and 69°C, but the action of the digesting bacteria will decrease sharply below 16°C. Production of gas is most rapid between 29°C and 41°C or between 49°C and 60°C. This is because two different types of bacteria multiply best in these two temperature ranges, but the high-temperature bacteria are much more sensitive to ambient influences. A temperature between 32°C and 35°C has proven most efficient for stable and continuous production of methane (Fowler 2003).

The pattern of gas demand, however, does not always coincide with its production. For this reason, the gas produced is collected and stored in a gas-holder. Most gas-holders in Africa are made of 3mm-thick steel sheets. Steel is susceptible to intense moisture-induced corrosion and gas-holders typically require surface protection coats of paint that are re-applied annually. A well-maintained gas-holder can be expected to last for 8-10 years in a dry climate. Polythene pipes are used for gas supply over long distances between the gas supply and the kitchen. Table 8-1 below compares two different sizes of biogas digesters, giving their respective outputs.

²⁷ The ratio of water to biomass in the biogas digester is normally 1:1

Table 8-1: Comparison of different sizes of biogas digesters

Digester Volume	Biogas Produced	Energy Content	Use
300 m ³	20 m ³	about 480 MJ	Electricity generation, cooking, lighting, running stationery engines e.t.c
10 m ³	4 m ³	about 96 MJ	cooking, lighting,
5 m ³	2 m ³	about 48 MJ	cooking, lighting,

Source: ABO (2007)

In the continuous flow digester, once the digester is fed with fresh material, an equivalent volume of the old material is displaced from the digester through the outlet pipe (by displacement through the over flow outlet pipe) to the slurry store. This material, which is rich in plant nutrients, can be used as fertilizer. The slurry store container typically holds a few days' worth of slurry, allowing the farmer some flexibility in deciding when and how to apply the fertilizer to the crops.

The key biogas technologies in Kenya (and in most of Africa) are three: floating drum, fixed dome and tubular reactors, as summarized in Box 8-1.

8.2.2. ADVANTAGES AND DRAWBACKS OF BIOGAS

The main advantage of biogas technology is that the most common raw material for this technology, animal dung, is readily available in many rural areas of Africa where livestock farming is practiced. In addition, the technology appears to be relatively uncomplicated if the collection of waste is streamlined. Biogas fuel can be used to replace (partially or completely) conventional fuels such as gasoline and diesel for lighting and cooking. It can also be promoted as an alternative to traditional biomass energy and alleviate the negative impacts associated with traditional biomass energy, especially on women and children.²⁸

Industrial scale biogas production can facilitate decentralized electricity generation in areas with no access to the grid. Its use prevents the formation of harmful intermediates and products formed during combustion of other fossil fuels such as polyaromatics, hydrocarbons, tar and soot.

Biogas also facilitates low-cost, environmentally sound waste recycling. The biological process of anaerobic digestion mineralizes organic material to produce slurry. This slurry can be used as fertilizer for improving the quality of farmland or for the production of organic pesticides, thereby reducing the need for high-cost artificial pesticides. Biogas thus yields multiple benefits to users (Karekezi and Ranja 1997; FAO 2007).

²⁸ Traditional biomass has serious health and environmental drawbacks. Indoor air pollution from unvented cooking stoves is a major contributor to respiratory illness in highland areas of Sub-Saharan Africa and reliance on biomass (especially charcoal) encourages land degradation (Karekezi, 2002a; Kantai, 2002). There is also a gender dimension to the domestic use of biomass. Women and children in highland areas of sub-Saharan Africa are exposed to high levels of indoor air pollution because of their lengthy periods spent in kitchens. The collection of traditional fuels is carried out primarily by women (and children) and uses up valuable time that could be better employed in education or generating income.

Box 8-1: Small-scale biogas technologies in use in Kenya

Floating drum technology - The key feature of this technology is the drum that floats on water or directly in the slurry, and depending on the amount of gas in the digester. As methanisation takes place and more gas is released, the drum is pushed up, indicating a rise in the amount of gas. When the gas is used up, the drum sinks. This provides a useful visual indicator of how much gas is available to households.

Fixed dome - Whereas the principles of methanisation remain similar to the floating drum biogas option, the key difference with this type of digester is that it is usually built under ground level, with only the plumbing, inlet and outlets visible (see Figure 8-2).

Figure 8-2: Fixed dome digester

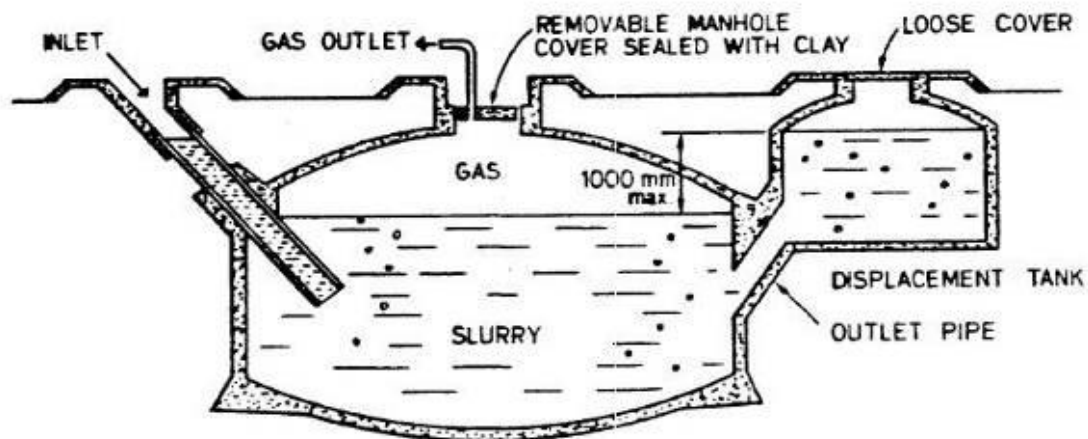

Fixed Dome (Chinese) Digester

Source: www.tente.com

Plastic tubular digesters - It is theoretically possible to use a plastic tube for methanisation and produce gas sufficient for cooking. However, success rates have been low. In 2006, a Kenyan company that was involved in making plastics ventured into the plastic tubular digester sector. The company, Pioneer Technologies, has improved on the plastic digester to make UV-treated, pressure-resistant tubular digesters of between 9m³ and 18m³.

According to the Chief Executive Officer of Pioneer Technologies, the plastic tubular digester was introduced in 2006 and since then, about 200 units have been installed countrywide. The technology looks simple to install and use but has complex technical considerations during installation, use and maintenance.

At least four of the five tubes visited had some technical/operational problems, which were easily addressed, but point to the need to review the technology. The digester seems to suffer from effects of variable temperature, and there is a possibility that the heat catalyses some reactions that produce other volatile gases as well as methane.

Source: ETC, 2007

A few drawbacks are associated with biogas systems. A biogas system needs significant attention from the operator. Poor maintenance is often associated with the failure of biogas plants. For example, failure rates of up to 50% were reported in China in the 1970s (Karekezi and Ranja, 1997).

These early failure rates contributed to the negative publicity associated with biogas projects in Africa, since the majority of the systems were originally from China. In addition, there are some problems with biogas when mass dissemination is attempted. First, dung collection has proved more problematic in rural Africa than anticipated. Second, the investment cost of even the smallest biogas unit is still prohibitive for most poor African rural households (Winrock 2007; ETC 2007).

The expense of installing a biogas plant can constitute a very substantial investment not only for rural farmers, but for rural municipalities as well. The typical cost of a large-scale biogas digester for generating electricity would cost between \$3,700 to \$7,000 per kWh (Government of Alberta 2007), relatively higher than the cost of installing other renewables as the following table shows;

Table 8-2: Energy generation costs from various renewable energy sources

Renewable Energy Source	Typical installed Cost (\$/kW)
Hydro Turbine	550 to 4,500
Geothermal System	1,800 to 2,000
Wind Turbine	1,000 to 3,000
Photovoltaic Module	8,000 to 12,000

Source: Retcreen (2005)

In addition, as with other combustible gases, the dangers of explosion exist. When replacement of worn-out biogas units is not carried out promptly, gas pipes may burst. Biogas slurry that is not properly handled can be environmentally harmful. In municipal and industrial waste biogas plants, the slurry (containing minerals) should be monitored for the possible presence for harmful content, such as broken glass pieces, metal objects, syringes and poisonous chemicals (Karekezi and Ranja 1997).

8.3. BIOGAS ENERGY POTENTIAL AND DISSEMINATION

8.3.1. POTENTIAL AND DISSEMINATION OF BIOGAS TECHNOLOGIES – GLOBAL EXAMPLES

The potential of biogas technology is immense and this technology has far-reaching benefits, especially for densely-populated rural areas. Biogas technology has been in use since the late 1940s, although its original purpose was not the production of fuel gas. Initially, biogas digesters were used for treating waste and producing fertilizer, particularly in China and India where biogas technology is perceived to be an integral component of rural sanitation and agricultural systems (FAO 2007).

Two countries that have embraced and widely used biogas technology are Nepal and India. Livestock plays an important role in the Nepalese farming system. Table 8-3 presents the technical potential of biogas based on a study carried out in Nepal.

Table 8-3: Potential of biogas in Nepal (2007)

Technical potential of biogas	1.9 Million Plants/ Units
Total economic potential	1 Million Plants/ Units

Source: BSP (2008)

Technical potential relates to the confirmed level of extractable power from a prospect that has been rigorously assessed through a series of exploratory surveys. Economic potential, on the other hand, indicates the actual number of biogas plants, out of the technical potential, that are financially viable to construct (Karekezi and Kithyoma 2005). In most cases, the economic potential of implementing renewable energy technologies is usually significantly lower than the technical potential.

In Nepal, the Biogas Sector Partnership (BSP) has the overall objective of furthering the development and dissemination of biogas plants as a mainstream renewable energy solution in rural Nepal, while addressing poverty, social inclusion and regional balance issues and ensuring enhanced commercialization and sustainability of the sector (BSP 2008). The Biogas Support Programme in Nepal has constructed almost 173,000 biogas plants (as of June 2008) and aims to install an additional 74,000 biogas plants by June 2009, increasing the access of biogas to remote and poor people. For this purpose, necessary and appropriate strategies such as offering subsidies for the biogas plant installations and cheaper financing options are to be applied (BSP 2008).

Dissemination of domestic and institutional biogas systems in selected Asian countries is shown in Table 8-4.

Table 8-4: Dissemination of domestic and institutional biogas systems in Asia

Country	No. Of Plants Installed	Source
Nepal	174,591	Bspnepal.org (2008)
India	2.5 million	Ganesh.co.uk (2008)
Bangladesh	10,000	Bangladesh Power Development Board (2007)
China	15.4 million	Hedon.info, 2004

Europe's biogas plants are mainly used for electricity generation and for gas production for vehicles, although some household biogas plants exist. The bulk of Europe's biogas production (almost 70%) is in the UK and Germany, and more than doubled between 2000-2005 (EurObserver 2004; 2006). Germany has experienced impressive biogas development since 2002, due, in part, to favourable feed-in tariffs for the production of electricity from biogas (Eriksson 2007).

8.3.2. BIOGAS POTENTIAL AND DISSEMINATION IN AFRICA

Biogas technology has received considerable attention over the last three decades in Africa. Findings from a study on biogas in Africa undertaken by SNV²⁹ indicate that the technical potential of domestic biogas in Africa is estimated to be 18.5 million biogas installations (Heedge and Sonder 2007).

Table 8-5 presents the estimated technical potential of biogas digesters in Africa, for both commercial and domestic use.

²⁹ The SNV study is part of a major biogas initiative called "Biogas for Better Life: An African Initiative". This initiative plans to provide 2 million African households with biogas digesters by 2020 at a cost of 600-800 Euros per installation.

Table 8-5: Technical potential of biogas digesters in Africa

Country	Technical potential (000 units)	Country	Technical potential (000 units)
Algeria	278	Mali	839
Angola	322	Mauritania	100
Benin	254	Niger	264
Burkina Faso	876	Nigeria	2,241
Cameroon	488	Rwanda	140
Chad	213	Senegal	439
Egypt	980	South Africa	579
Ghana	278	Sudan	1,784
Guinea	255	Tanzania	1,781
Kenya	1,259	Uganda	1,314
Madagascar	678	Zambia	341

Source: Winrock (2007)

The technical viability of biogas has repeatedly been proven in many field tests and pilot projects in the region. Although data on actual dissemination is not readily available and varies widely where available, some estimates of the dissemination of biogas digesters (domestic and institutional) are provided in

Table 8-6.

Table 8-6: Number of installed biogas digesters in selected countries of Africa

Country	Units
Ethiopia	1,000
Kenya	500
Tanzania	≤ 4,000
Burkina Faso	20
Botswana	215
Burundi	279
Lesotho	40
Uganda	600
Zimbabwe	200

Sources: Karekezi and Kithyoma (2005)

The history of biogas digesters installation in Eastern Africa stretches back to the 1950s when the first digesters were installed in Kenya (ETC 2007). Biogas extension programmes in the region have mainly been through government ministries of energy and agriculture as well as energy research institutions (Heegde and Sonder 2007).

Tanzania is a leader in biogas technologies in the eastern African region. The Centre for Agricultural Mechanisation and Rural Technology (CAMARTEC) has been extensively involved in the development and production of biogas systems for households and institutions. It is estimated that more than 4,000 domestic-size biogas plants have been installed in Tanzania during the past 20 years, transforming Tanzania into a leader in the promotion of this technology in Africa (AFREPREN/FWD 2008a).

Numerous biogas promotional campaigns were carried out by Ministries of Energy and Agriculture in Kenya in the 1980s and 1990s, especially among rural farmers. It is estimated that only 25% of the 300 units installed between 1980 and 1990 are operational today (Kuria 2002). The Ministry of Energy in Kenya is currently implementing a national biogas programme, aimed at reviving most of the stalled biogas plants installed in the 1980s and 1990s. Other documented biogas projects in Kenya include a public latrine block in Kibera slum in Nairobi, which uses human waste to generate biogas for water heating and domestic use (AFREPREN/FWD 2008a).

In Uganda, biogas technology was introduced by the Church of Uganda in the early 1980s with the installation of two Indian-type (floating drum) biogas digesters. These digesters acted as good demonstration units, leading to the construction of several more digesters in Ankole district. Available information indicates that these digesters worked for a number of years, after which they developed problems that were sometimes due to lack of maintenance. A Nepalese digester was also installed at Mbarara, but never functioned (Karekezi and Ranja, 1997).

In 2000, the Government of Uganda, through the Energy Resources Department, implemented a biogas programme in Kampala and its environs. About 20 biogas digesters of 8m³ capacity each were constructed. Out of the 20 biogas plants, 2 were installed in institutions while the rest were installed in households. Most of the digesters are still functional to date (The Republic of Uganda 2007). Currently there are about 600 biogas digesters installed in the country (most of them are located around the capital city, Kampala), although not all are operational (Winrock International 2007).

In Rwanda, dissemination of large-scale biogas digesters to prisons to treat toilet wastes and generate biogas for cooking has registered significant success. The initiative by the Kigali Institute of Science, Technology and Management (KIST) won the Ashden Award for Sustainable Energy in 2005. The first prison biogas digester became operational in 2001 and currently KIST has installed biogas digesters in almost half of the 30 prisons in the country. The Ministry of Internal Security purchases the biogas plants for the prisons at a cost of approximately £50,000 for a 500m³ plant. Due to its success, the initiative is receiving support from organizations such as UNDP and the Red Cross. An important factor for the success of the initiative is that local residents (including prisoners) have received technical and business training. To date, over 30 civilians and 250 prisoners have been trained – a key factor in the relative success of biogas in Rwanda (Ashden Awards 2008; Macharia Undated).

Biogas technology was introduced in Southern Sudan in 2001 through a UNICEF/OLS-supported Biogas Pilot Project at a Secondary School in Rumbek (Kuria, 2002). About 1,000 biogas digesters have also been disseminated in Ethiopia (Winrock International 2007).

In Malawi, at least 14 institutional and domestic biogas digesters have been installed since 1976. Institutional digesters have been the more successful. Biodigesters have not been successfully promoted in Lesotho, despite studies showing that the technology has potential in the country. An estimated 350 biogas digesters are installed in Zimbabwe (MOEPD, Undated).

On a much larger scale, the Harare Municipality in Zimbabwe operates a biogas digester using municipal sewage at its Harare sewage treatment plant. However, the latest information available to the authors indicates that the produced biogas is being flared, not utilised for energy (Karekezi *et al.* 2007). There are proposals to develop landfill gas by Ethekwini Municipality (South Africa) to generate 10 MW of electricity. Madagascar has also initiated a UNDP-supported project to sort, collect and recycle waste, including generating energy from waste. In Burkina Faso, there have been a number of biogas demonstration projects, mainly in schools and institutions (ETC 2007).

The Netherlands Ministry of Foreign Affairs in conjunction with other development partners, SNV (Netherlands Development Organization) and Hivos, launched a biogas initiative in Nairobi in May 2007. The initiative dubbed, "Biogas for Better Life" intends to bring renewable energy to 20 million

households in some 25 African countries. Kenya, Uganda, Ethiopia and Rwanda are some of the East African countries included in the project. National programmes have been launched with an aim of constructing the initiative's first 50,000 biogas plants (Heegde and Sonder, 2007). In Rwanda, the national programme has already begun. This initiative is in line with the Dutch Government's commitment to improving access to renewable energy in developing countries.

8.4. KEY DRIVERS AND BARRIERS FOR BIOGAS DEVELOPMENT

8.4.1. KEY DRIVERS

Increases in oil prices (which have since dropped dramatically but could still rise again) are an important rationale for promoting biogas as an alternative energy source for household and institutional lighting and cooking fuel. The increase in oil prices of 2007 and early 2008, which peaked at above US\$150 per barrel, had an adverse impact on the poor, who rely largely on kerosene for cooking and lighting (AfDB 2006). The African Development Bank has advised African governments that high energy prices should be viewed as a signal to reduce countries' heavy reliance on oil and make use of alternative clean energy resources (AfDB 2006). Biogas can provide an important alternative to kerosene and diesel, as mentioned earlier. Biogas is a clean cooking fuel and can replace traditional biomass, thus alleviating the negative impacts associated with traditional biomass.

According to a 2003 study conducted by Earthlife Africa, an NGO based in South Africa, there is substantial potential for the biogas industry to create more jobs than conventional fossil fuel-based technologies (see Table 8-7). The construction of biogas digesters is labour-intensive and can generate jobs in rural areas. Biogas also provides the opportunity to strengthen Africa's agricultural sector, especially where the biogas by-product is used as fertilizer. Improvements in agricultural productivity arising from biogas development would therefore indirectly contribute to increased job generation.

Table 8-7: Job creation potential of bio-fuels

Fuel	Jobs per TWh
Bio-diesel	16,318
Bio-ethanol	3,770
Biogas	1,341
Gas	130
Nuclear	80
Coal	700

Source: Earthlife Africa/SECCP Report (2003)

A third driver for biogas is the positive impact on sanitation. Biogas units have an additional benefit as they can effectively address sanitation problems of cities and rural areas. Biogas plants can safely use wastes that are often poorly disposed of and which pose health risks to the population. There is therefore a strong argument for promoting biogas projects as part of local authority sanitation projects where possible. It is estimated, for example, that around 100 million households are living in the rural areas of Africa. Half of those possess livestock that can provide the input material for biogas digesters.

In addition, biogas, both at the industrial and household level, can play a key role in reducing GHG emissions by replacing fossil fuels such as kerosene and mitigating greenhouse emissions from waste dumps, thus attracting carbon financing for further development of the technology (ETC 2007; FAO 2007).

8.4.2. BARRIERS

Although the installation of biogas plants is often less costly than most other renewable/alternative energy options, biogas plants are still capital-intensive. As mentioned earlier, the average cost of constructing a biogas plant is often well beyond the reach of a typical African rural household. As shown in Table 8-8 the cost of a fixed dome reactor, the least expensive biogas option, would require an investment that is equivalent to that required to buy 10-15 cows—a considerable sum for a typical African rural household. It is worth noting that the costs have reduced over the years.

Table 8-8: Biogas units in Kenya – key features

Technologies	1. Floating drum reactor	2. Fixed dome reactor	3. Tubular reactor
Retail selling price for 16 m ³ ³⁰	€1,188-1,403	€648-1,296	€399 (for 9m ³)
Experience	Introduced in 1950s	Introduced in 1990s	Introduced in 2006
Promoters	Tunnel technologies GTZ-SEP	SCODE PEMAGI REECON GTZ PSDA	Pioneer technologies
Prevalence	>1,000	300-800	150-200

Source: ETC (2007)

Larger biogas investments require solid technical and financing proposals which clearly illustrate the project's internal rate of return (IRR), net present value (NPV) and other performance indicators in order to secure financing. The expertise for drafting and developing high-quality financial proposals is usually not available in rural areas (AFREPREN/FWD, 2007).

The under-supply of decentralized animal waste has proven to be one of the biggest barriers to the development of biogas technology, especially in the developing countries of Africa where there are scatterings of small-scale livestock herders and farmers. In most rural areas of Africa, animal husbandry is undertaken by small-scale farmers who have on average 5-10 heads of livestock. Few farmers practice zero grazing.³¹ Therefore, animal waste is normally scattered around the countryside as the livestock move from one place to another in search of pasture. Consequently, there is no organized livestock waste collection and management system that ensures that the available animal waste in the rural areas is collected in one central place and utilized effectively for energy generation (ETC 2007). However, there are many large-scale farms and institutions such as

³⁰ For domestic purposes, a 16 m³ biogas digester producing roughly about 6 m³ of biogas daily is large enough to digest waste from a house. As a general rule of thumb, 1 cubic metre (m³) of gas will cook three meals a day for a family of 4-6 and provide lighting (Forst, 2002).

³¹ An animal husbandry strategy in which the plant material is harvested daily and fed to livestock in a dry lot. Avoids damage to pasture by cattle walking on it.

colleges, boarding schools, universities, abattoirs and hospitals with large amounts of human and animal waste that can provide substantial feedstock for biogas plants (Heegde and Sonder 2007).

There are other feedstocks that can be used for biogas generation. These include human waste (sewage) and bio-degradable agricultural waste. Although they work well, the main disadvantage of using alternative feedstocks is the effort needed in their collection, as in many parts of eastern and southern Africa, rural settlement patterns consist of scattered homesteads located in the middle of their respective farming plots (a problem that is less acute in tropical West Africa, dominated by centralized village settlement patterns). In addition, use of human wastes for energy generation is still not yet to be widely accepted in Africa and perceived as unclean by many African rural communities (Winrock 2007).

Water is essential for a biogas installation to function and only a small percentage of the population has access to sufficient water. This limits the adoption of the biogas technology. If the number of people with access to water in rural areas of Africa is increased,³² the potential market for biogas technology could roughly equal 30-50 million installations.

Local biogas companies in the region identify the following key barriers to biogas dissemination in Africa: low levels of awareness and a lack of promotion, a lack of availability of both consumer and vendor finance, a shortage of technicians and skills (particularly for installing smaller systems), a lack of quality control and a scarcity of good building materials. Some companies and institutions interviewed in Kenya mentioned the following key challenges (ETC 2007):

- Limited capacity to handle orders
- Inadequate construction equipment
- Inadequate private and public means of transport to potential customers, combined with impassable roads.
- The presence of hard bedrock, which hinders or prevents excavation of a potential biogas site.

8.5. KEY FACTORS FOR BIOGAS DEVELOPMENT

8.5.1. POLICY AND INSTITUTIONAL ISSUES

Experience shows that the introduction and success of any technology is, to a large extent, dependent on the existing policy framework. Government policies are important because of their ability to create an enabling environment for mobilizing resources and encouraging private sector investment (Karekezi and Kithyoma 2005). Policies for bio-fuels development (which encompasses biogas) in Africa are largely under-developed. Although a number of countries are in the process of formulating biofuel strategy documents, it still remains unclear whether biogas is one of the key options to be promoted, as more emphasis is placed on liquid biofuels (such as bio-diesel and bio-ethanol) for transport.

Some of the available laws governing biogas development and distribution cut across sectoral laws governing water, sanitation, forestry, agriculture and environment and hence require complex

³² Some biogas digesters contain up to 75% water in the digestion chamber (Forst, 2002). But with an estimated population of about 300 million people in Sub-Saharan Africa without access to water (World Bank, 2006), promotion of the technology becomes rather difficult.

institutional coordination capacity (AfDB FINESSE 2006). Lack of a supportive and well-coordinated institutional framework can lead to the failure of biogas programmes as they lack local champions (Amigun *et al.* 2007).

In Kenya, The Energy Act 2006 has provisions for promotion of renewable energy, which includes biogas. However, the necessary legal and regulatory framework for biogas still needs to be put in place. Some of the biogas companies have come together to form a biogas installers network, which intends to collaborate with the Ministry of Trade and the Kenyan Bureau of Standards to develop standards and ensure that members' operations conform to these standards (ETC 2007).

8.5.2. FINANCING ISSUES

As mentioned earlier, production of bio-gas is often a high upfront cost venture, and many biogas programmes require government support in the initial start-up phases. There are limited financing options available for those who want to invest in biogas technology individually or as a community. Traditional banks are unwilling to provide finance due to market uncertainties and perceived high risks. There is also limited data and information on the biogas industry to guide investors and financiers in making sound judgments and decisions in biogas projects development.

Investment in biogas plants, both large and small scale, normally requires detailed and complex financing proposals which are able to derive, in a convincing fashion, the project's internal rate of return (IRR) or net present value (NPV). The expertise for drafting and developing high quality financial proposals is usually not available in almost all rural areas of Africa, thus limiting the growth of biogas. In addition, there is limited capacity for developing biogas projects to access CDM financing.

8.5.3. TECHNICAL / CAPACITY ISSUES.

Advanced technical skills and knowledge are required in the design, installation, commissioning, operation and maintenance of biogas plants (see Box 8-2 for case examples of Kenya). Capacity building, training and sharing of skills and expertise constitute an important prerequisite for successful biogas promotion (Thom and Banks 1994; SADC TAU/UNDP 1997). The very limited number of trained technicians capable of constructing and managing and maintaining biogas plants is a major challenge to biogas development in Africa (AFREPREN/FWD 2007).

Box 8-2: Why biogas projects failed in Kenya

- **Poor maintenance:** Digesters are built without proper explanation to users on how to care for them.
- **Poor dissemination strategy by promoters:** Biogas roll-outs are carried out with little or no digester research and development to understand quality and end-use issues.
- **Poor planning and monitoring by promoters:** It is important to consider why one is building a biogas digester. Biogas digesters are methane gas-producing fertiliser plants as well as sanitation aids. If there is no use for the fertiliser produced and the additional sanitary benefits of biogas remain unexploited, then much money and work will have been spent to collect a comparatively small amount of gas..
- **Poor construction or design leading to gas pressure problems:** Many people have seen functional biogas digesters and attempted to build their own. However, biogas digesters are not as simple as they look. They must be properly designed and constructed. If an unqualified person attempts to build a digester, he/she will probably run into problems.

- **Acceptance problem:** The re-charging of the digester may be seen as a dirty job and hence leads to poor ownership responsibility by users. This is especially true in the case of batch digesters, which require loading of organic material waste and unloading after digestion.

Source: Adapted from ETC, 2007

8.6. RECOMMENDATIONS

8.6.1. POLICY OPTIONS

In order to transform biogas into a widely used technology in Africa, governments need to enact directly supportive policies that support biogas development. Biogas can be promoted as an option for reducing reliance on traditional biomass as well as a public health management system. Such a policy measure will boost the growth and development of biogas not only as an alternative energy source but as a small-scale affordable renewable energy source (AFREPREN/FWD 2008a; AFREPREN/FWD 2007). Many of the policy options that have proved successful in promoting biogas can be found in Asia.

The promotion of biogas as an option for reducing dependence on traditional biomass has been successfully adopted in Nepal, where cooking using biogas is promoted as a cleaner option, cutting the risk of respiratory and eye diseases caused by the black smoke inherent in traditional methods. Women in particular will benefit from this cost-effective and clean energy use.

The Nepalese Government has created the Alternative Energy Promotion Commission (AEPIC), an umbrella organization for all alternative energy initiatives such as solar, micro-hydro, biogas and geothermal. The Biogas Support Programme (BSP) is also a nationally-mandated institution that promotes biogas development in the country. BSP has set targets for biogas development which it tracks and develops over time. The AEPIC and BSP ensure that the required assistance for the biogas programme from different sectoral Ministries is streamlined and properly coordinated.

One innovative option for promoting biogas could be through the creation of Rural Energy Agencies built on existing Rural Electrification Agencies whose current mandates are largely limited to increasing electrification levels. The mandate of these agencies could be expanded to include the promotion of other energy sources, such as biogas technology, in rural areas where applicable. Biogas could thus be able to benefit from the rural electrification levies charged to each electricity consumer.

To promote electricity generation from medium and large scale biogas plants, Governments can offer attractive feed-in-tariffs that allow sale of electricity to the grid. This policy measure can be strengthened by initiating a standard Power Purchase Agreements (PPAs) for small scale electricity producers.

8.6.2. FINANCING OPTIONS

Access to finance has always hampered the growth and development of biogas technology. In order to hasten its growth and development, training on biogas technology for financiers such as banks and other lending institutions, to enhance their understanding of the viability of investments in biogas, would be a valuable initiative. Heightened awareness among financiers will invariably increase access to financing options for investors who want to construct biogas digesters.

Another way of increasing access to financing options for biogas technology is by easing the conditions that are usually attached to finance for renewable energy projects. Over-stringent

conditions have a negative impact on the application and uptake of financing for biogas investments (AFREPREN/FWD 2006).

The option of introducing subsidies for biogas projects needs to be carefully evaluated by African countries. Subsidies are an important option for reducing the upfront costs of biogas units. A proven financing measure would be to introduce subsidies as well-designed incentives that encourage investment in biogas technology development. In Nepal, the Government introduced a subsidy of about 25%, which is provided for every digester constructed. This subsidy is paid directly to the construction company and has led to increased growth in construction of biogas digesters. The Government ensures that the biogas digester user receives after-construction-service from the company that constructed the bio-digester for 3 years (ETC 2007).

In the case of Nepal, the Agricultural Development Bank of Nepal (ADBN) provides credit to farmers at 10% interest rate and payable in 5 years, to construct bio-digesters. Other Microfinance Institutions (MFIs) are also involved in the provision of credit for farmers interested in establishment of a biodigester for biogas production. The estimated cost of the biodigester in Nepal is about NRs 32,000 -40,000 (US\$550-650). The government provide 20-25% subsidy and the ADBN or MFIs provides the credit (BSP 2008)

Nepal has also been successful in securing CDM financing for biogas development which could provide useful lessons for African countries (see Box 8-3). Partnership and knowledge-sharing with Nepal should be encouraged.

Box 8-3: Biogas Sector Partnership (BSP) and Clean Development Mechanism (CDM)

BSP has been the first to secure a CDM Project in Nepal. Two CDM Projects of 19,396 plants constructed under BSP Phase-IV, have been registered with the CDM Executive Board. An Emission Reduction Purchase Agreement (ERPA) for the 2 projects has been signed with the World Bank for trading of the Emission Reductions from the two projects for first seven years starting 2004/05. Annual reporting and verification for the two projects for crediting years 2004/05 and 2005/06 have been completed

From these two projects, the annual carbon revenue (net of project development and verification expenses) would be around NPR 42,000,000 (or around US\$607,000).

At least 2 more CDM Projects are in the pipeline to be registered.

Source: BSP (2008)

An additional example of financing for biogas in Cambodia is provided in Box 8-4.

Box 8-4: Case of bio-digesters and micro loans for farmers in Cambodia

SNV and the Dutch development bank, FMO have joined efforts to provide bio-digesters including micro loans to farmers in Cambodia. A cooperation agreement was signed with local partners in capital Phnom Penh. The use of bio-digesters was introduced in March 2006 in Cambodia. However, financing of the installations—about 400 US\$— is beyond the financial capacity of majority of farmers. Through an innovative microfinance program of FMO, the purchase of an installation will be more feasible for them.

With support of SNV, more than 220,000 bio-digesters have already been installed in Asia, especially in Nepal and Vietnam. A simple biogas plant can be run by any family with at least two adult cows or four pigs. The family toilet can also be connected to it. Such a plant will generate enough gas to power a cooking stove and a lamp. Unlike firewood, biogas is a clean, quick and comfortable cooking fuel.

In Cambodia, 1,200 bio-digesters have been installed already on cash-basis. This number will now rapidly increase with the attractive loan scheme FMO is providing through a Cambodian micro-finance institute. The National Biodigester Programme (NBP) will provide technical support. It is expected that 17,500 plants will be installed in Cambodia in the coming years.

Source: SNV (2007)

8.6.3. TECHNICAL

As mentioned earlier, there is limited expertise available for managing and operating the biogas digester plants, largely due to the low levels of education and lack of knowledgeable and trained (skilled) personnel available in African countries. Specialized training courses on biogas technology development need to be undertaken in tertiary learning institutions in order to increase the number of trained (skilled) personnel capable of installing and maintaining biogas digesters.

For example, in Rwanda, training of local technicians (including prisoners) has contributed immensely to the success of the country's biogas initiative. Investment in training will ensure that quality standards are kept high to avoid failure of biogas projects in Africa. Development of local capacity will lead to widespread replication of biogas technology across the African continent (Biogas for Better Life 2009).

Research and development on biogas technology should be supported. Other activities will include training workshops and study tours, based on the specific country needs (AFREPREN/FWD 2006; AFREPREN/FWD 2007).

8.7. REFERENCES

- ABO Wind. (2007) How a Biogas Plant Functions. Berlin: ABO Wind. Website (accessed 27th July 2009) http://www.abo-wind.com/en/bio-energy/biogas_plant_functions.html#prod
- AfDB FINESSE. (2006) *Sustainable Production and Consumption of Biomass for Energy in Africa: Subregional Synthesis Report – Eastern & Central Africa*. Tunisia: AfDB.
- AFREPREN (2001) *Power Sector Reform in Africa: Proceedings of a Regional Policy Seminar, Occasional paper No. 5*. Nairobi: AFREPREN.
- AFREPREN (2002) *African Energy Data Handbook, Occasional Paper No. 13*. Nairobi: AFREPREN/FWD.
- AFREPREN (2003) *African Energy Database*. Nairobi: AFREPREN.
- AFREPREN/FWD (2006) *Cogen for Africa FSP (Full Size Project) Brief Final Report*. Nairobi: AFREPREN/FWD.
- AFREPREN/FWD (2006) *Contribution of Renewables to a Sustainable Power Sector in Kenya, Occasional Paper No. 29*, AFREPREN/FWD, Nairobi.
- AFREPREN/FWD (2007) *Sustainable Energy and Community Participation in Biomass-Based Cogeneration in Kenya, Occasional Paper No. 31*. Nairobi: AFREPREN/FWD.
- AFREPREN/FWD (2008a) *Scaling up Bio-fuels in East Africa: Background Paper for the International Conference on Scaling-Up Renewables in Africa*. Nairobi: AFREPREN/FWD.
- AFREPREN/FWD (2008b) *The Promise of Biofuels in Africa - Status, Challenges and Opportunities*. Nairobi: AFREPREN/FWD.
- AGAMA (2008) South Africa: Household Biogas Feasibility Study. Website (accessed 27 July 2009): <http://www.biogasafrica.org/Documents/South-Africa-Feasibility-Study.pdf>
- Arnold, M., Kohlin, G., Persson, R., Shepherd, G. (2003) Fuelwood revisited: what has changed in the last decade? *CIFOR Occasional Paper No.39*. Jakarta: Center for International Forestry Research.
- Arumugam, S., Zinoviev, S., Foransiero, P. Miertus, S., Müller-Langer, F., Kaltschmitt, M., Vogel, A., Thraen, D., and Kemausuor, F. (2007) *Bio-fuels: Technology Status and Future Trends, Technology Assessment and Decision Support Tools*. Trieste: ICS-UNIDO

- Ashden Awards (2007) Management of domestic and municipal waste at source produces biogas for cooking and electricity generation. Website (accessed 20 July 2009): http://www.ashdenawards.org/files/reports/Biotech_India_2007_Technical_report_.pdf
- Barron, G. (2003) A Small-Scale Biodigester Designed and Built in the Philippines by Gerry Barron. Website (accessed 20 July 2009): <http://www.habmigern2003.info/biogas/Baron-digester/Baron-digester.htm>
- Davis, (2007) Monthly Update: Global Biofuel Trends. Washington DC: World Resources Institute. Website (accessed 20 July 2009): <http://earthtrends.wri.org/updates/node/180>
- Deepchand, K. (2001) *Bagasse-Based Cogeneration in Mauritius – A Model for Eastern and Southern Africa, Occasional Paper No. 2*. Nairobi: AFREPREN/FWD.
- Deepchand, K. (2002) Promoting equity in large-scale renewable energy developments: the case of Mauritius. *Energy Policy* 30: 11-12.
- Earthlife Africa/SECCP Report. (2003) NGO Forum “Turning Policy into Reality: from the ground up”. Website (accessed 20 July 2009): www.gefweb.org/Partners/partners-Nongovernmental_Organ/documents/NGO_forum_report_Oct.26.06.pdf
- Electrigaz. (2007) What type of waste produces biogas? Trois-Rivières, QC: Electrigaz. http://www.electrigaz.com/faq_en.htm
- ESDA. (2005) *National Charcoal Survey: Exploring the Potential for a Sustainable Charcoal Industry in Kenya*. Nairobi: Energy for Sustainable Development Africa (ESDA).
- ETC 2007. *Promoting Biogas Systems in Kenya: A Feasibility Study*. Website (Accessed 27 July 2009): <http://www.biogasafrica.org/Documents/Kenya-Feasibility-Study.pdf>
- FAO. (Undated). Chapter Seven: Anaerobic Processes, Plant Design and Control. Website (accessed 27 July 2009): <http://www.fao.org/docrep/T0541E/T0541E09.htm>
- FAO. (2000) *Environment and Natural Resource Working Paper: Rural Energy Supply*. Rome: FAO.
- FAO. (2003) Wood Energy. Rome: FAO. Website (accessed 20 July 2009): <http://www.fao.org/forestry/FOP/FOPH/ENERGY/databa-e.stm>
- FAO. (2007) Sustainable wood energy systems. Rome: FAO. Website (accessed 20 July 2009): <http://www.fao.org/forestry/foris/pdf/infonotes/infofaoenglish-sustainablewoodenergysystems.pdf>
- Forst, C. (2002) Technologies Demonstrated at Echo: Horizontal Biogas Digester. Website (accessed 27 July 2009): http://www.wcasfmra.org/biogas_docs/Horizontal%20Biogas%20Digester.pdf
- Fowler, S., 2003. Biogas production. Website (accessed 27 July 2009): <http://www.habmigern2003.info/biogas/methane-digester.html>
- Gistnic-Rural Technologies (2009) *Fixed Dome Biogas Manure Plant ATRC Model II, Suruchi Campus, Bardoli-394 601*. Gujarat: Agriculture Tool Research Centre. Website (accessed 27 July 2009): <http://results2.ap.nic.in/general/rt/gistvill3.jsp?rno1=15&rno=46>
- Government of Alberta. (2007) *Economic Feasibility of Anaerobic Digesters*. Edmonton: Government of Alberta, Agriculture and Rural Development. Website (accessed 20 July 2009): [http://www1.agric.gov.ab.ca/\\$Department/deptdocs.nsf/all/agdex12280](http://www1.agric.gov.ab.ca/$Department/deptdocs.nsf/all/agdex12280)
- Heegde, F. and Sonder, K. (2007) Biogas for Better Life: An African Initiative. Website (accessed 27 July 2009): <http://www.snvworld.org/en/Documents/20070520%20Biogas%20potential%20and%20need%20in%20Africa.pdf>
- IEA. (2007) World Energy Statistics. Paris: IEA. Website (accessed 20 July 2009): <http://www.iea.org/Textbase/stats/index.asp>
- Karekezi, S. and Ranja T. (1997) *Renewable Energy Technologies in Africa*. London: Zed Books.
- Karekezi S., Mapako, M., and Teferra, M. (2002) Africa: improving modern energy services for the poor. *Energy Policy* 30: 909-913
- Karekezi, S. and Kithyoma, W. (eds.) (2005) *Sustainable Energy in Africa: Cogeneration and Geothermal in the East and Horn of Africa – Status and Prospects*. Nairobi: AFREPREN/FWD
- Macharia, K., Undated. Progress Towards Environmental Sustainability. Website (accessed on 27 July 2009): www.undp.org/energyandenvironment/sustainabledifference/PDFs/Africa/Rwanda.pdf
- MOEPD (Ministry of Energy and Power Development). (Undated) The Biogas Technology. Government of Zimbabwe. Website (accessed 27 July 2009): <http://www.energy.gov.zw/renewableenergy/biogas%20technology.htm>
- MOEPD (Ministry of Energy and Power Development). (2007) The National Biodiesel Feedstock Production Programme. Government of Zimbabwe. Website (accessed 20 July 2009): <http://www.energy.gov.zw/renewableenergy/Biodiesel.htm>

- Post Carbon Institute (2008) Rethinking The Direct Use of Biogas Effluent as a Fertilizer. Frankfort, KY: Energy Farms Network. Website (accessed 20 July 2009): <http://archive.energyfarms.net/taxonomy/term/39>
- Rao, R. (2007) 'Biomass Gasification'. *The Tribune Online Edition*. Website (accessed 27 July 2009): <http://www.tribuneindia.com/2007/20070420/science.htm#2>
- Republic of Uganda (2006) *Background to the Budget 2006/07 Fiscal Year*. Website (accessed 20 July 2009): http://www.finance.go.ug/docs/BTTB_06%20Final.pdf
- Republic of Uganda (2007) Renewable Energy. Website (accessed 20 July 2009): <http://www.energyandminerals.go.ug/renenergy/Renewable%20Energy%20Source.html>
- Retscreen (2005) Combined Heat and Power Project Analysis. Ottawa: Natural Resources Canada. Website (accessed 20 July 2009): www.retscreen.net/...php/.../RETSscreen4_overview_CHP.ppt
- Senadeera, et al, 2007. *Implementation and Optimisation of Anaerobic Digestion to South Australian Climatic Conditions*. Institute for Sustainable Systems and Technologies Initiative. University of Adelaide webpage: http://works.bepress.com/cgi/viewcontent.cgi?article=1010&context=wijitha_senadeera (accessed on 27th July 2009).
- SNV. 2007. Bio-digesters and Micro Loans for Farmers in Cambodia. Website accessed on (27th July 2009): <http://www.snvworld.org/en/aboutus/news/Pages/HomeASI-ENG-Biodigestersforfarmers.aspx>
- The Manila Times. (2001) 'Charcoal, yes; Wood, No'. Manila Times Publishing Corporation. Website <http://www.manilatimes.net/national/2005/apr/12/yehey/enter/20050412ent2.html>
- Thom, C. and Banks, D.I. (1994) Biogas as a rural domestic energy source: a pilot study. *Journal of Energy R&D in Southern Africa* 5(4): 121-125.
- University of Florida. (2008) Feedstocks for Biogas Production. Gainesville, FL: University of Florida. Website (accessed 20 July 2009): <http://biogas.ifas.ufl.edu/feedstocks.htm>
- UNDESA. (2007) *Small-Scale Production and Use of Liquid Biofuels in Sub-Saharan Africa: Perspectives for Sustainable Development*. New York: UNDESA.
- United Nations Statistics Division. (2005) *Progress Towards the Millennium Development Goals, 1990-2005: Goal 1. Eradicate Extreme Poverty and Hunger*. Website (accessed 20 July 2009): http://mdgs.un.org/unsd/mdg/Resources/Attach/Products/Progress2005/goal_1.pdf
- UNCTAD (2006) *The Emerging Biofuels Market: Regulatory, Trade and Development Implications*. Geneva: UNCTAD.
- Wilkie, A., 2009. Feedstocks for Biogas Production. Gainesville, University of Florida. Available from <http://biogas.ifas.ufl.edu/feedstocks.htm> (accessed on July 10, 2009)
- Wudine, Z. (2007) Ethiopia's New Energy Strategy Opens Way for Bio-Fuel. Website (accessed 20 July 2009): <http://www.geocities.com/akababi/bionov07041.htm>

9. EVALUATING BIOMASS ENERGY COGENERATION OPPORTUNITIES AND BARRIERS IN AFRICA: THE CASE OF BAGASSE COGENERATION IN THE SUGAR INDUSTRY

By Stephen Karekezi, Waeni Kithyoma and Maryanne Kamoche

Energy, Environment and Development Network for Africa (AFREPREN/FWD)

Contact: afrepren@africaonline.co.ke

9.1. ABSTRACT

This chapter examines biomass cogeneration energy potential at the global level, but devotes specific focus on Africa's experience with (and potential for) biomass cogeneration based on bagasse, an agricultural waste product of the sugar cane industry. Although biomass cogeneration has traditionally been practised by sugar factories in Africa, the technologies that are installed are inefficient and do not optimize the use of biomass as a fuel. With the use of modern and efficient cogeneration systems, factories can generate enough heat for their process requirements and electricity to meet factory requirements, as well as electricity for export to the grid. The chapter reviews the opportunities available for biomass cogeneration, key drivers and the barriers preventing the significant potential of cogeneration from being fully realized. It suggests policy, financial and technical measures that would assist in accelerating cogeneration development in Africa.

9.2. BACKGROUND AND INTRODUCTION

Biomass is a versatile energy source. It is one of the most common forms of energy used in the world today. In Africa, where it constitutes 70-90% of energy used, the main sources of biomass include trees, timber waste, agricultural residues and human and animal wastes. With recent high prices (which have since experienced dramatic reductions, demonstrating once again the instability of fossil fuel prices) and environmental and financial incentives such as carbon finance beginning to take root, modern biomass energy options such as biomass-based cogeneration are becoming increasingly economically attractive. Studies have shown that biomass-based cogeneration has the potential to supply a significant part of African energy needs if effectively and sustainably harnessed.

Biomass cogeneration (simultaneous production of more than one form of energy using a single fuel and facility) has been successfully piloted in several African countries in recent years. This report examines biomass cogeneration energy potential at the global level but focuses on Africa's experience with, and potential for, biomass-based cogeneration development. It reviews the opportunities available for biomass cogeneration, key drivers and the barriers preventing the significant potential of cogeneration from being fully realized. It also proposes policy, financial and technical measures that would assist in accelerating cogeneration development in Africa.

9.2.1. FUNDAMENTALS OF COGENERATION

Cogeneration is the simultaneous production of electricity and process heat from a single dynamic plant. A cogeneration plant heats up steam that drives a turbine to produce electricity. Various forms of biomass can be used to fuel the plant, including bagasse (sugar cane waste) from the sugar industry and wastes from paper and pulp, palm wood and rice industries (AFREPREN/FWD, 2006). Cogeneration offers opportunities for generating electricity and/or heat energy with limited capacity investments, while avoiding the negative environment impacts of increased fossil fuel combustion (where renewable fuels are used), making it both energy efficient and environmentally beneficial. Cogeneration industries can be located in remote areas not connected to the utility grid. In remote settings with the electricity interconnected to users at the source, transmission and distribution losses are minimized.

Globally, biomass-based cogeneration has been widely applied in forest industries and agro-industries such as sugar factories, rice mills and palm oil factories. As the trend in wood industries is shifting towards integrated wood complexes,³³ cogeneration plants are being implemented increasingly in this sector, too. In some cases, rice husks, as well as coconut husks and shells, can also be used as a fuel in a cogeneration plant while abating the environmental pollution associated with their disposal. If appropriate technologies are implemented, cogeneration not only allows agro-industries to be self-sufficient in energy, but can also help them to secure an additional and potentially lucrative revenue stream by exporting excess electricity produced to the national grid.

Typically, electricity is more valuable than heat in a cogeneration plant. However, efficient cogeneration systems save on heat that would otherwise have been lost and can be used for industrial processes, space and water heating and cooling. The excess heat can also be used to produce more electricity (AFREPREN/FWD 2006; Retscreen Undated).

³³ Integrated wood complexes are a system of managing forest industries, where the various industries are situated adjacent to the forest, resulting in an economic complex consisting of forest plantation, sawmills, wood-based panel industry, furniture industry, pulp and paper industry, etc. This concentration results in better collection of wastes, which can be used for cogeneration.

Figure 9-1 compares the efficiency of cogeneration plants and standard and separate power and heat generation systems. It shows that conventional energy supply systems require about 40% more primary energy than a cogeneration system to meet the same energy needs. In addition, the losses from separate generation are higher (44%) than for cogeneration system.

Figure 9-1: Comparison of energy balances between cogeneration and separate power generation

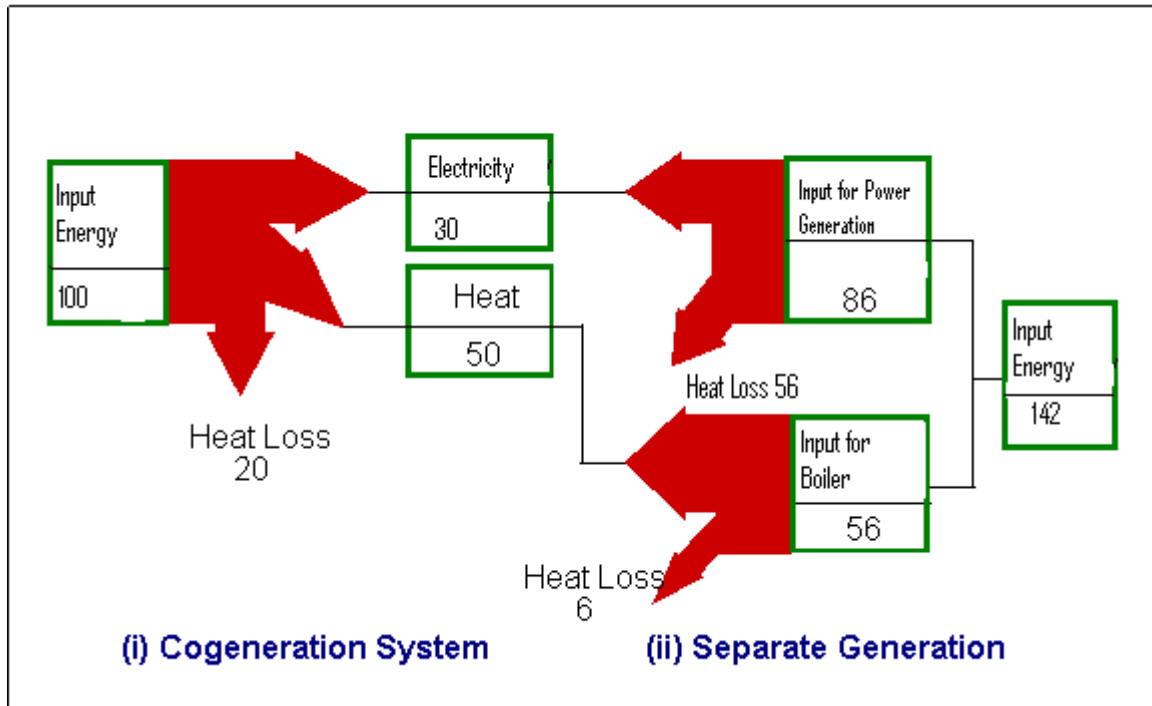

Source: Mohanty (2000)

9.2.2. COGENERATION EQUIPMENT AND SYSTEMS

Cogeneration equipment can be sub-divided into two main categories: Core equipment and auxiliary equipment.

Core equipment includes:

- Fuel handling and preparation
- Boilers
- Heat recovery steam generators
- Prime movers (e.g. gas turbine, microturbine, steam turbine, combined cycle system)
- Generators

Auxiliary equipment includes:

- Heat exchangers
- Transformers
- Control and monitoring system
- Combustion equipment
- Emission control
- Ash and residue handling
- Water treatment

There are various types of fuel-driven cogeneration systems based on prime movers. These are:

- Boiler and steam turbine system
- Gas turbine system
- Combined cycle system
- Reciprocating engine systems
- Fuel cell systems
- Tri-generation systems

THE BACK-PRESSURE STEAM TURBINE (BPST)

Figure 9-2 presents a back-pressure steam turbine system (BPST) cogeneration system. This system is characterized by air and steam cycles. Air is introduced to the air inlet using the blower, and is then preheated and fed to the boiler at an appropriate air-to-fuel ratio with biomass resource. Combustion of the fuel mixture results in a thermo-chemical reaction that produces heat, which is subsequently used for raising steam. The steam is then expanded through the back-pressure turbines to the pressure required for downstream factory processes. The turbine acts as a reducing valve, generating useful electrical and mechanical power (Mbithi 2003; Retscreen Undated). Exhaust steam comes into contact with the cold surface of the water tubes of the condenser, releasing condensate. The condensate is then pre-heated before being returned to the boiler. Operating at pressures in the range 15-25 bars, the back-pressure steam turbine has the lowest thermal efficiency of the steam-Rankine cycle systems used in the sugar industry.

Figure 9-2: Bagasse-based BPST

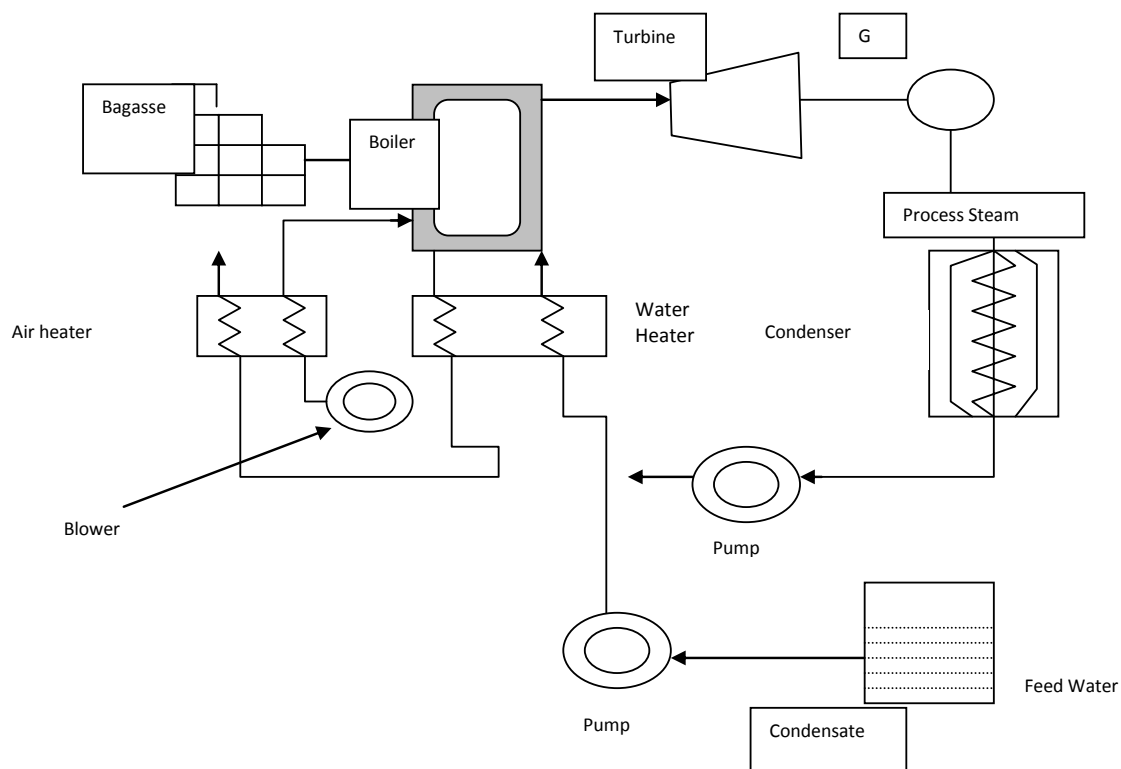

Source: Mbithi (2003)

COMBINED EXTRACTION STEAM TURBINE (CEST)

In this system, condensing turbo-alternators are added to the back-pressure turbine. The trend worldwide has been to consider using the condensing-extraction steam turbine (CEST) cogeneration system for power generation for large-scale electricity export to the grid. It follows that the higher the primary steam pressure and temperature, and the lower the steam pressures for motive purposes, evaporation and condensing, the greater the export energy for a fixed input of fuel to the steam generators (Retscreen Undated). Figure 9-3 shows the Combined Extraction Steam Turbine (CEST).

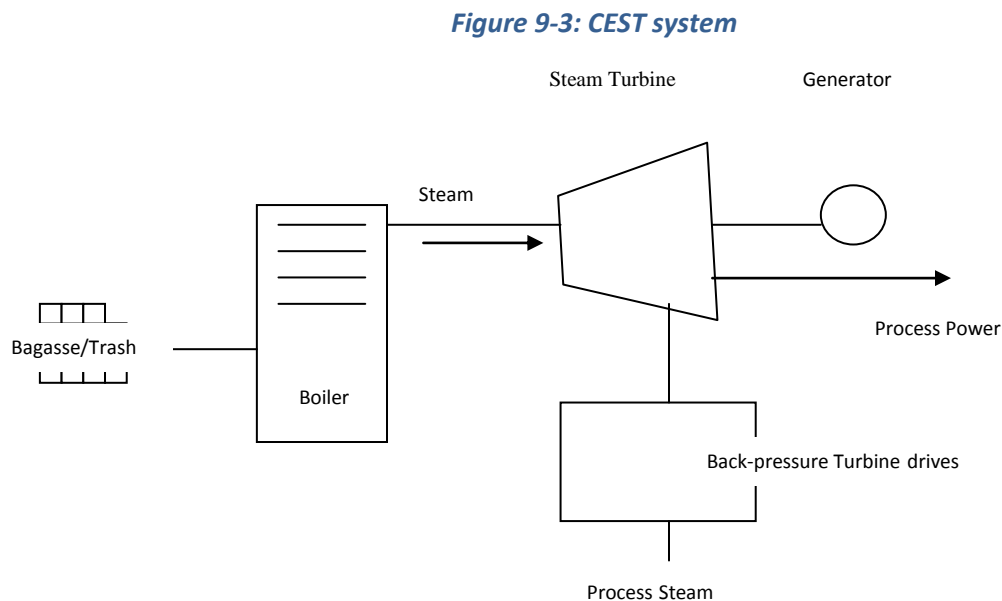

Source: Mbithi (2003)

During the off-season, CEST units can be operated in condensing mode, producing electrical power only, using stored biomass resource or other alternative fuels. The exhaust steam of the back-pressure turbine drives provides all process steam demand. Steam is sometimes tapped off at two points: the high-pressure line for electricity production and the low-pressure lines for the production process (e.g. sugar processing). The waste steam can be recycled to generate more electricity. CEST systems operate at 40-85 bars (Mbithi, 2003).

BIOMASS-INTEGRATED GASIFIER/GAS TURBINE COMBINED CYCLE (BIG/GTCC)

This innovative technology involves the partial oxidation of biomass at temperatures of the order 800°C-1200°C to produce combustible fuel gases. Energy is produced by integrating existing Brayton (gas turbine) power-generating or cogeneration cycles, already developed for natural gas, to closely coupled biomass gasifiers.

In the biomass-integrated gasifier/gas turbine combined cycle, the biomass resource is dried before being converted into a combustible fuel gas in the gasifier. The gas is then cleaned to remove impurities before entering the gas turbine-generator. A heat recovery steam generator (HRSG) is used to raise steam from the hot exhaust of the gas turbine and a steam turbine-generator is used to produce additional electricity.

Gasification has the potential of being cost-competitive with conventional CEST technology using biomass resource as fuel, while dramatically increasing the electricity generated per unit of

sugarcane processed by approximately 15-20%, as shown in Table 9-1. Pilot and demonstration units of the BIG/GTCC system have been tested and developed and commercialization is under way in some countries, such as Brazil and Sweden (Retscreen Undated).

Table 9-1: Electrical energy efficiency

Prime Move	Size Range (MWe)	Electrical Generating Efficiency
Extraction steam turbine	1 to 300+	20 – 35%
Combined cycle gas turbine	3 to 300+	35 – 55%

Source: COGEN 3 ; European Focal Point (2003)

Biomass cogeneration costs are highly variable. The main initial costs relate to power generation equipment, fuel handling, heating (or cooling) equipment, electrical interconnection, and access roads. Some of the main recurrent costs include: fuel, operation and maintenance, and equipment replacement and repair.

Table 9-2 shows estimated cost for various types of equipment used in a cogeneration plant.

Table 9-2: Equipment cost of various turbines using different types of energy source

Power equipment type	Typical installation cost (\$/kW)
Reciprocating engine*	567 to 1620
Gas turbine	446 to 2025
Gas turbine – combined cycle ^ψ	567 to 1215
Steam turbine	446 to 1215

Note: Typical installed cost values in US \$ as of January 1, 2005.

* A reciprocating engine, also often known as a piston engine, is a heat engine that uses one or more reciprocating pistons to convert pressure into a rotating motion.

^ψ A gas turbine – combined cycle is characteristic of a power producing engine or plant that employs more than one thermodynamic cycle

Source: RETSCREEN International (2005)

O&M costs are estimated at 0.004 \$/kWh for the steam turbine and 0.10 \$/kWh for the gas turbine (NREL 2003). Fuel costs are incurred where the fuel is to be purchased. However in the case of bagasse cogeneration, the cost is modest (primarily handling/storage costs), since it is available at the factory.

9.2.3. BIOMASS COGENERATION FEEDSTOCK

As mentioned earlier, cogeneration has been widely applied in agro-industries, with the sugar industry recording the most widespread use of cogeneration. Additional cogeneration feedstocks that can be utilized for cogeneration are provided in Table 9-3.

Table 9-3: Feedstock calorific values

Biomass	Calorific Value Kcal/Kg	Biomass	Calorific Value Kcal/Kg
Castor stick	4,300	Coconut wastes	3,720
Castor seeds shell	3,860	Eucalyptus saw dust	4,400
Cotton pods	4,200	Ground nut shell	4,500
Cotton Stalk	4,200	Mulberry stick	4,380
Saw dust	4,400	Sun flower stalk	4,300
Straw	3,700	Sugar cane leaves	4,200
Wood (hard)	4,400	Saw dust	4,500
Bagasse	3,363	Sweet sorghum stalk	4,100
Coir pith	4,100	Tobacco dust	1,164
Cotton shell	4,200	Tea waste	4,000
		Tobacco Stem	3,041

Source: IIT (2002)

Currently bagasse is widely used in many parts of the world because of its high calorific value, its availability and its proximity to industry and end-users. There have been limited studies on the potential of other wastes. This chapter focuses on the use of wastes/residues for cogeneration, specifically bagasse, which has been proven in many parts of the world.

9.3. POTENTIAL AND STATUS OF BIOMASS COGENERATION

9.3.1. COGENERATION POTENTIAL

All sugarcane-growing countries have significant potential for biomass cogeneration. There are over 90 sugarcane-producing countries in the world, but only 15 countries account for 87% of production (Netafim 2008). Countries with significant bagasse cogeneration potential include South Africa, Cuba, Brazil, India, Thailand, Pakistan, Colombia, Mexico and the Philippines.

Sugar is produced in a many African countries. It is a major agricultural export for Ethiopia, Madagascar, Malawi, Mauritius, Mozambique, Swaziland, Zambia and Zimbabwe. The potential for electricity generation from bagasse is high, since cogeneration equipment is almost always an integral component of sugar factory design (Deepchand 2001).

As shown in Table 9-5, available estimates indicate that a number of African countries can meet significant proportions of their current power generation needs from cogeneration in their respective national sugar industry.

An abundant supply of biomass wastes is also generated by industries using wood and other forest outputs as raw material. These wastes could be used as feedstock for cogeneration plants.

Wood waste is a renewable resource that has potential to generate electrical power. The term “wood waste” refers to low-grade timber material with no other identifiable market or environmental value. This includes material that is left in the forest after the higher-value timber resources have been harvested, and the sawdust, shavings, off-cuts and other wastes associated with timber processing. There is significant potential for cogeneration using wood wastes, which has not been exploited.

In the milling process of rice, two main residues are produced. These are rice germ and rice husks. Husks make up around one quarter of the weight. Only a small fraction of this is utilized, for instance, to fire distillery furnaces. Rice husks can be used in co-generation plants. Coffee husk is fibrous, low in moisture, uniform in size and low in ash. Coffee husk can also be used as feedstock for cogeneration plants.

Table 9-4 provides the potential for electricity generation from bagasse in various sugar production countries.

Sugar is produced in a many African countries. It is a major agricultural export for Ethiopia, Madagascar, Malawi, Mauritius, Mozambique, Swaziland, Zambia and Zimbabwe. The potential for electricity generation from bagasse is high, since cogeneration equipment is almost always an integral component of sugar factory design (Deepchand 2001).

As shown in Table 9-5, available estimates indicate that a number of African countries can meet significant proportions of their current power generation needs from cogeneration in their respective national sugar industry.

An abundant supply of biomass wastes is also generated by industries using wood and other forest outputs as raw material. These wastes could be used as feedstock for cogeneration plants.

Wood waste is a renewable resource that has potential to generate electrical power. The term “wood waste” refers to low-grade timber material with no other identifiable market or environmental value. This includes material that is left in the forest after the higher-value timber resources have been harvested, and the sawdust, shavings, off-cuts and other wastes associated with timber processing. There is significant potential for cogeneration using wood wastes, which has not been exploited.

In the milling process of rice, two main residues are produced. These are rice germ and rice husks. Husks make up around one quarter of the weight. Only a small fraction of this is utilized, for instance, to fire distillery furnaces. Rice husks can be used in co-generation plants. Coffee husk is fibrous, low in moisture, uniform in size and low in ash. Coffee husk can also be used as feedstock for cogeneration plants.

Table 9-4: Global bagasse potential for cogeneration from sugarcane

Country	Sugarcane production (tonnes/yr)	Potential for electricity production (GWh / yr)
		Assuming that 1 tonne of cane generates 100kWh of electricity
Brazil	514,079,729	51,408
India	355,520,000	35,552
China	106,316,000	10,632
Thailand	64,365,682	6,437
Pakistan	54,752,000	5,475
Mexico	50,680,000	5,068
Columbia	40,000,000	4,000
Australia	36,000,000	3,600
Cuba	11,100,000	1,110
USA	27,750,600	2,775
Phillipines	25,300,000	2,530
TOTAL	1,285,864,011	128,586

Source: FAO (2007)

Table 9-5: Cogeneration (bagasse) potential for Eastern and Southern Africa

Countries	Cogen Potential, 82 Bar* (MW)	Cogen potential as % of total installed national power generation capacity from all sources
Ethiopia	30.9	4.3%
Kenya	190	16.2%
Tanzania	97.8	11.1%
Uganda	46.0	15.2%
Malawi	56.5	23.7%
Swaziland	185.0	144.5%
Sudan	156.9	20.8%

* Refers to the operating pressure of the cogeneration system; 82 bar cogen systems are still not widespread in Africa, but are now in use in Mauritius. The potential is based on current/existing sugarcane production.

Source: Deepchand (2002), EIA (2004), Karekezi and Kimani (2002), Kiva (2008)

9.3.2. STATUS OF COGENERATION

The World Alliance for Decentralized Energy (WADE) estimates that in 2005, 11 countries had 3.9 GW of installed bagasse-based generating capacity. Brazil contributed 1.7 GW (Bell, 2005). Table 9-6 presents global electricity production from biomass in eight leading countries over the past ten years.

Table 9-6: Electricity production from biomass from 8 leading countries

Year	TWh
1995	85.3
2002	110
2003	118.2
2004	131.4
2005	134.9

The current status of cogeneration (primarily, sugar industry-based) in selected Eastern and Southern Africa countries is provided in Table 9-7.

Table 9-7: Current cogeneration installed capacity in selected African countries

Country	Current Cogeneration Installed Capacity (MW)	Installed National Capacity (MW)	As % of total of National Power Generation Installed Capacity
Ethiopia	13.4	814	1.65%
Kenya	73.0	1,197	6.10%
Malawi	18.5	300	6.17%
Sudan	55.3	1,023	5.41%
Swaziland	53	128	41.41%
Tanzania	33.3	1,080	3.08%
Uganda	20.0	380	5.26%

Sources: Gwang'ombe (2004), Yuko et al. (2004), Kamese (2004), Engorait (2004), Wolde-Ghiorgis, (2004), Kagucia (2005), Mbithi (2005), Isingoma (2005)

Mauritius provides an example of highly successful use of cogeneration which now meets over 40% of the country's national electricity generation total, with over half of this coming from bagasse from the sugar industry (Veragoo 2003). Chapter 10 provides a detailed examination of cogeneration in Mauritius.

ETHIOPIA

Bagasse-based energy cogeneration for export to the utility grid is not yet practiced in Ethiopia. There are plans though, to sell power to the national utility in the future. All of the country's sugar factories (Metahara, Wonji/Shoa, Finchaa) co-generate electricity to meet the power and heat needs of their plants. However, they also use electricity from the national utility for irrigation, and to electrify households within their estates during the off-crop season (Wolde-Ghiorgis 2004).

The co-generation facility at the Finchaa Sugar Factory (FSF), located about 335 km from Addis Ababa, is able to power the sugar plant as well as part of its irrigation systems and surrounding towns and villages during the cropping season. FSF generates 4.3 MW for the sugar plant when it is working at a crushing rate of 4,000 tonnes of cane per day and with the ethanol plant at full production (maximum capacity of 45,000 litres per day) and generates an additional 1.16 MW to meet outside loads (Wolde-Ghiorgis 2004). There are also plans to establish a new sugar estate (Tendaho Sugar Factory) in Ethiopia, which will be privately owned (Zeneba 2007).

KENYA

In Kenya, cogeneration technology with bagasse as the primary fuel is practised in 7 sugar factories in the western part of the country. Companies include Muhoroni, Chemilil, Mumias, Nzoia, South Nyanza, Western Kenya and Kibos. Currently, these companies produce an average of 1.8 million tonnes of bagasse per year, 60% of which is used as boiler fuel for steam generation, with electricity being generated from surplus steam. The remaining 40% is disposed of, at times at a cost (Yuko 2004).

Mumias Sugar Company is self-sufficient in electricity generation and has signed a Power Purchase Agreement to export 2 MW to the national grid (Yuko 2004; Rapuro 2005). Mumias has now constructed a 35 MW cogeneration plant, which will allow export of 25 MW to the grid. Another private sugar company, West Kenya Sugar, is self-sufficient in its own power demand, and is planning a second-phase expansion of its cogeneration plant which will allow it to export a significant amount of power to the grid. The remaining sugar companies are at various levels of expanding their cogeneration plants, to meet internal needs as well as to sell power to the grid.

In addition to the existing factories that have plans for expansion, Busia Sugar Company, which currently owns a sugar cane plantation and manages around 8,000 farmers (with a plan to increase to 30,000 farmers), plans to establish a sugar factory with a capacity of 4,200 tonnes of cane per day. This company plans to incorporate a cogeneration unit with a capacity of 20 MW in the initial phase, if the viability of the project is ascertained (AFREPREN/FWD, 2006).

TANZANIA

Cogeneration in Tanzania is practiced in sugar-processing factories, in a wattle processing plant, and in a saw mill. The country's main sugar companies—Kilombero Sugar Company (KSC) and the Mtibwa Sugar Estate (both located in Morogoro region), Kagera Sugar Company in Kagera region and Tanganyika Planting Company (TPC) near Mount Kilimanjaro, are utilizing bagasse in their cogeneration plants.

The Kilombero Sugar Company (KSC) recently signed a contract with the main utility, TANESCO, to deliver 2 MW of electricity into the national grid during the crushing season. Mtibwa Sugar Estate generates a total of 10 GWh of electricity during production season and imports about 4 GWh annually from TANESCO for irrigation and domestic estate purposes. Power generation at TPC is through two back-pressure turbo alternators rated at 3 MW and 2.5 MW, respectively. TPC plans to increase the cane-crushing rate of the factory from the existing 130 TCH to 200 TCH, giving the company an opportunity to implement a higher capacity cogeneration system. Cogeneration at Kagera Sugar Company is done through two steam turbines rated at 2.5 MW. There is a potential for the extra power which can be used for electrifying nearby villages (AFREPREN/FWD 2006, Gwang'ombe 2004).

Tanganyika Wattle Company (TANWAT), located in Iringa region, operates a cogeneration plant that is fired by wood logs and spent wattle barks. The cogeneration plant in TANWAT has an installed capacity of 2.5 MW, out of which, until recently, about 35% was exported to the TANESCO isolated grid at Njombe (recent information obtained from the manager of the TANWAT cogeneration plant indicates that export of power to the grid has now been halted as the surrounding areas have access to lower-cost electricity from the national grid). The sales of power to third parties are at US\$8.5 to US\$11 per kWh. TANWAT has plans to build a second power plant with a capacity of 15 MW. Saohill SawMill, located in Iringa region, uses its sawmill waste as fuel for a steam engine that generates 1 MW electrical power for internal use (AFREPREN/FWD, 2006, Gwang'ombe, 2004).

UGANDA

In Uganda, three sugar factories produce an average of 130,000 tonnes of sugar annually. Until its recent expansion, the Kakira Sugar Factory had a rated capacity of 3,000 tonnes of cane per day and an installed capacity of 14 MW of electricity; Kinyara Sugar Works (KSW) has an installed capacity of 2MW; and the Sugar Corporation of Uganda has an installed capacity of 4 MW (Engurait 2004; REA 2009).

These factories produce electricity from cogeneration to meet most of their internal factory demand. Kakira Sugar Works successfully negotiated a power supply contract with the Uganda Electricity Board (UEB) to supply 7.5 MW to the national grid (Engurait 2004; Kamese 2004). With liberalization and a favorable policy framework, existing sugar factories are planning to rapidly expand their cogeneration capacity (Engurait 2004).

MALAWI

Currently, there are two sugar factories in Malawi. These are the Dwangwa and Nchalo sugar factories. Their combined annual production of bagasse is 60,000 tonnes. Almost all of the bagasse generated goes to cogeneration systems for the factories' own use. The sugar plantation in Dwangwa is located about 200 kilometers south-east of the country's capital, Lilongwe. It has an installed power cogeneration capacity of 7 MW. The plant can sometimes produce only up to 6 MW during the low season of sugar cane crushing. The sugar factory consumes 3.5 MW, while water pumping for cane irrigation consumes 1.5 MW. Staff houses together use a total of 1.5 MW. The factory imports up to 1 MW from the main utility, ESCOM.

The other sugar plantation is located at Nchalo about 150 kilometers south of Blantyre, the commercial city of Malawi, with an installed capacity of 11.5 MW. However, because the sugar plant is bigger, the maximum power demand for the whole establishment is 20 MW, which means that the sugar company imports up to 9.5 MW from ESCOM. There are plans to implement highly efficient cogeneration systems in these factories to cover the energy requirements of the factories and sell excess power to the grid (AFREPREN/FWD 2006).

SUDAN

Sudan is one of the largest sugar-producing countries in the world. It has four operational sugar factories and an additional two under construction. Three of the existing factories (New Halfa, Gunied and Sennar sugar factories) are owned by the state and managed by the Sudan Sugar Company. The fourth is Kenana Sugar Company, which is a privately-owned factory. The design of each of the new sugar factories under construction includes a cogeneration plant. There are plans to move towards high-pressure advanced cogeneration systems to diversify the country's power supplies (Karekezi and Kithyoma 2006).

SWAZILAND

For a relatively small country, Swaziland has a large sugar industry, producing more than 600,000 tonnes of sugar in 2005. This production is shared among three sugar factories, namely Simunye Sugar Mill, Mhlume Sugar Mill and Ubombo Sugar Mill. The three factories have a combined capacity of 26,400 tonnes of cane per day, and the cogeneration systems use bagasse and coal as fuel. Coal is used during the milling season to stabilize combustion in the boilers and during the off-milling season for other activities such as ethanol production and refinery (Karekezi and Kithyoma 2006).

9.4. KEY DRIVERS AND BARRIERS FOR BIOMASS COGENERATION DEVELOPMENT

9.4.1. KEY DRIVERS

REDUCTION OF OIL IMPORTS

There is a growing realization in Africa that dependency on imported fuel has a negative impact on regional economic development. Out of 47 of the world's poorest countries, 38 are net oil importers—the majority of them from Africa (Gueye 2006). In Eastern Africa and the Horn of Africa, Sudan is the only net exporter of petroleum.

Imports of petroleum products have a significant negative impact on the economy and balance of payments of oil-importing African countries, partly due to the recent high oil prices (which have since come down—demonstrating the price volatility of oil) but more importantly due to the instability of oil prices. Table 9-8 shows the impact of oil and diesel imports on the import bill of selected African countries—with oil and diesel imports making up 10-20% of total imports in a large number of African countries (26) (ADB 2006). The high cost of oil imports is compounded by the fact that a large number of African countries are landlocked, which increases oil supply transport costs as well as increases the vulnerability of oil supplies to disruptions.

Table 9-8: Oil Imports as a percentage of total imports

Category (in %)	Number of countries
Less than 5	5
5 – 10	14
10 – 15	16
15 – 20	10
20 – 25	1
More than 25%	1

Source: ADB (2006) – Computed using African Development Bank data

Biomass-based cogeneration can be an attractive option for reducing the dependence on imported oil used for generation of electricity. This is particularly important for countries in East and Southern African which are often faced with droughts that reduce the hydro-power generation capacity, leading to the installation of emergency oil-fired power generation units. Not only are these emergency power units costly (sometimes up to 3 times the normal cost of power), but they are also environmentally unfriendly and contribute to greenhouse gas emissions. Existing estimates show that if bagasse cogeneration potential was developed in Kenya, it would be sufficient to replace the need for emergency diesel generated power (AFREPREN/FWD 2008).

Biomass cogeneration can improve the security of the electricity supply industry, as it increases the diversity of sources of electricity generation. This is an important driver for many African countries, which are faced with intermittent power crises due to drought-induced reduction of hydro-power capacity or high oil prices.

ENERGY SUPPLY SECURITY AND STABILITY

Biomass-based cogeneration can also be an attractive option for oil-exporting African countries. As shown in the Figure 9-4, it is estimated that the reserves of major oil-producing African countries such as Angola and Egypt, among others, have fewer than 20 years of oil extraction remaining – a significant and growing portion of their oil is used for power generation to meet national electricity demand. Biomass cogeneration can help to partially meet local electricity needs, thereby replacing oil-generated power which could, in turn, result in additional years of oil reserves and help free up oil for exports—often, the principal source of income for oil-producing countries.

Figure 9-4: Remaining years of oil exploration

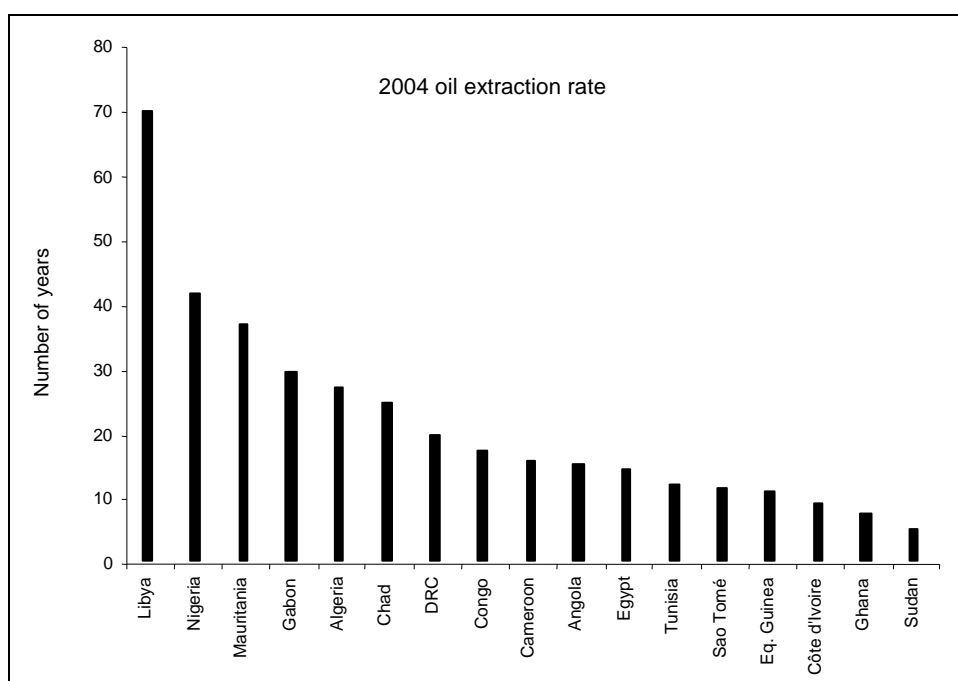

Source: ADB (2006)— Computed using IEA data

INCREASING COSTS OF ELECTRICITY

Increasing costs of electricity in the region are an important driver for cogeneration development in agro-industries. Cogeneration reduces the cost of production by reducing or eliminating use of

electricity from the national grid. With rapidly rising electricity prices in many African countries, self-sufficiency in power supply can transform a struggling agro-industry into a profitable and viable business.

ADDITIONAL REVENUE STREAM FOR AGRO-INDUSTRY FACTORIES

Many sugar factories in eastern and southern Africa are struggling with low national and international prices for sugar. In November 2005, EU announced sugar prices were to be cut by 36% over 4 years (DEFRA 2005). Sugar factories in Africa who export to the EU need to diversify revenue streams as continued reliance on sugar sales is becoming less attractive.

With a cogeneration plant that sells excess electricity to the grid, a sugar factory gains an additional and more reliable revenue stream that can counter the low prices for sugar. In Mauritius, sugar millers are making more money from power sales than sugar sales.

RURAL ELECTRIFICATION

In most African countries, cogeneration is mainly utilized in the sugar industry. Coincidentally, the sugar industry in Africa tends to be located in rural areas with very low electrification levels. Cogeneration plants can assist in expanding access to electricity in rural Africa. For example, in Kenya, some sugar factories supply the excess electricity generated from the cogeneration plant to the sugar mill workers' residential areas within the sugar factory premises. Rural electrification leads to a wider range of activities that the local residents can engage in, thereby promoting income generation in rural areas.

9.4.2. BARRIERS

SUSTAINABLE PRODUCTION OF FEEDSTOCKS

Availability of feedstock on a sustainable basis is crucial to the success of the cogeneration industry. Most cogeneration plants in Africa use agricultural residues as feedstock but a dramatic expansion of cogeneration might require additional land area, increase in yields or diversification of feedstock. Use of more land for feedstock might lead to competition with food production and thus contribute to higher food prices. In addition, cogeneration from conventional biomass could conflict with conservation of biodiversity. Crops such as sugar cane that are source of feedstock for cogeneration are water-intensive and can threaten water resources through expanded use of irrigation. Large-scale use of pesticides and fertilizers, such as that common in almost all large-scale agro-industries, can raise sustainability concerns.

TECHNICAL CHALLENGES

Although modern, high-pressure and efficient biomass cogeneration systems are technically well proven and used widely in some parts of the world, even in nearby Mauritius, there are very few examples of high-pressure systems (i.e. 60 bar and over) implemented in mainland Africa. The absence of successful examples is a barrier in convincing potential developers to invest in modern biomass cogeneration technologies. The presence of successful reference high-pressure and more efficient cogeneration plants as concrete examples could accelerate the adoption and widespread dissemination of cogeneration.

Low technical skills hinder dissemination and sustainability of high-pressure and more efficient biomass cogeneration technology as advanced technical skills and knowledge are required in the design, installation, commissioning, operation and maintenance of cogeneration plants. In the case

of biomass cogeneration, skills mobilization and upgrading are required to bring together the required expertise to develop successful projects. Capacity building, training and sharing of skills and expertise constitute an important pre-requisite for successful biomass cogeneration promotion (Thom & Banks, 1994; SADC TAU/UNDP, 1997).

FINANCIAL CHALLENGES

Financing is one of the single most important barriers to cogeneration investments. In spite of its importance, project developers of cogeneration projects tend to postpone the mobilizing of investment finance to a latter stage of project development, a move which often delays the whole implementation process. Biomass cogeneration is a high up-front cost venture, and many programmes require support in the initial start-up phases. Access to finance or availability of affordable finance is a major constraint. Traditional banks are unwilling to provide finance due to market uncertainties and perceived high risks. There is limited data and information on the biomass cogeneration industry in Africa that can be used to guide investors and financiers in making sound judgments and decisions in cogen project development.

POLICY AND INSTITUTIONAL CHALLENGES

Experience shows that the introduction and success of promoting biomass cogeneration on a major scale requires substantial private sector investment, which, in turn, requires a supportive policy and regulatory framework that better defines the risks and rewards of cogeneration investments. Government policies are important because of their ability to create an enabling environment for mobilizing resources and encouraging private sector investment (Karekezi and Kithyoma 2005).

On the one hand, poor or inappropriate government policies can create or raise barriers to the widespread implementation of these technologies; on the other hand, the creation and faithful implementation of supportive policies and programmes could help overcome barriers, create confidence in the market, and stimulate investments in modern and efficient biomass cogeneration projects. A major barrier discussed in detail later is the absence of attractive pre-determined feed-in tariff policies and standard power purchase agreements (PPAs).

9.5. POLICY AND INSTITUTIONAL FRAMEWORK FOR COGENERATION

9.5.1. POLICIES OUTSIDE AFRICA

A growing number of sugar-producing countries in both developed and developing parts of the world have crafted and implemented policy incentives to promote cogeneration.

Table 9-9 describes some of the incentives developed by the Government of India, which have contributed significantly to the growth of bagasse cogeneration in India.

In Brazil, the current energy / climate policy allows for the surplus electricity to be sold to electricity distributors. Various government incentive programmes have been established to promote cogeneration (see Table 9-10).

Table 9-9: Policies for bagasse cogeneration by the Indian Government

Incentive	Description
Income Tax Holiday	Five year tax holiday with 30% exemption from income tax
Customs Duty	A lower 20% duty levy for new and renewable sources of energy power projects of less than 50MWe capacity (under Project Import Category). This covers machinery and equipment component parts required for generation of electrical power
Central Excise Duty	Exemption for renewable energy devices, including raw materials, components and assemblies.
Central Sales Tax	Exemption for renewable energy devices, including raw materials, components and assemblies.
General Sales Tax	Exemption is available in certain States.
Accelerated Depreciation	100% depreciation in the first year can be claimed for the following cogeneration equipment: <ol style="list-style-type: none"> 1. Fluidised Bed Boilers 2. Back pressure, pass-out, controlled extraction, extraction and condensing turbines for power generation with boilers 3. High efficiency boilers 4. Waste heat recovery equipment

Source: WADE (2004)

Table 9-10: Incentives for the development of bagasse cogeneration in Brazil

Programme	Key Features
“Programme for Incentive of Alternative Electric Energy Sources” (PROINFA)	<p>PROINFA was created in April 2002 to increase the share of biomass (inclusive of cogeneration), wind and small-scale hydropower systems in the Brazilian energy generation mix from Autonomous Independent Producers (AIPs). The first phase of PROINFA aims to integrate 3.3GWe of capacity through contracts between Eletrobrás (the State electricity company) and AIPs lasting up to 15 years. The second phase will guarantee that, after the initial 20-year period, these technologies will supply 10% of annual electricity demand, accounting for at least 15% of market growth.</p> <p>The feed-in tariffs under PROINFA, made public in March 2004, are currently set at R\$93.77-169.08 (US\$32.17-58.00) per MWh for biomass generation. This corresponds to approximately 80% of the national end-user average tariffs.</p>
Energy Reallocation Mechanism (ERM)	ERM is the financial mechanism by which the risks of hydro electric power (HEP) are shared amongst the participants of the central dispatching system. Developing grid-connected generation from wind, biomass and qualified cogeneration allows for the mitigation of such risks.

Source: Compiled from WADE (2003), UNIDO (2003), Falcao (2002), Galdino & Lima (2001) and Trench et al. (2004)

9.5.2. POLICIES IN AFRICA

SUPPORTIVE LEGISLATION AND POLICY

A number of African governments have realized the importance that green energy can play in improving a country's economy and increasing the opportunities to benefit from carbon credits. Mauritius has been a leader in this area and has provided various policies and attractive pre-determined feed-in tariffs to promote biomass cogeneration. Some East African countries such as Kenya, Tanzania and South Africa have also begun to provide attractive and pre-determined feed-in tariffs to promote cogeneration.

Table 9-11 provides a brief inventory of policies and measures supporting cogeneration for selected African countries. These policies either mention cogeneration or biomass energy explicitly or they are indirectly referred to through supporting measures to promote renewables or to promote Independent Power Production (IPP) as a way of increasing national power generation to meet the growing demand for electricity.

Table 9-11: Inventory of policies supporting cogeneration in selected Eastern and Southern Africa Countries

Country	Reference	Paragraph/article supporting or mentioning cogeneration
Ethiopia	Energy Policy of the Government of Ethiopia	The policy indirectly supports cogeneration in agro-industries. "Wherever possible, energy demand in the agricultural sector will be met through locally-produced modern energy resources"
	Extract from AFREPREN/FWD's Occasional Paper 24, 2004	"The Agriculture Development Led Industrialization (ADLI) strategy makes agricultural development as the corner stone and engine for all programs on sustainable development in Ethiopia. Included in the plan are poverty alleviation and multi-sectoral socio-economic developments in both rural and urban settlements. Although not fully considered and integrated in the original formulation of the strategy, it is now being recognized that energy is a necessary input for all development activities. In this context, therefore, since biomass-based cogeneration is the result of agro-industrial development, its optimum and efficient uses should be viewed positively in many respects. In addition, it is important to first appreciate the potential merits and demerits that are likely to be associated with co-generation in Ethiopia."
	National Communication, 2001	"The policy document stipulates that alternative energy sources and technologies shall be developed to meet increasing demand and encouraged and supports adoption of renewable energy technologies. It also encourages and support rational and use of modern fuels and, introduction of energy conservation and energy saving measures in all sectors. The national energy policy also clearly states that development and use of energy resources shall give due consideration to the protection of the environment"

Kenya	Energy Bill, Section 4.7, 2006	“Cogeneration using bagasse as a primary fuel is a practice in the domestic sugar industry in Kenya. The industry comprising seven sugar companies produces an average of 1.8 million tonnes of bagasse with fiber contents of about 18 % by weight annually. Out of this quantity, 56 % was used in co-generation using an installed capacity of 25 MW and the balance disposed at a cost. Mumias is the only sugar company among the seven that is self-sufficient in electricity production and has the capacity to export its surplus to the national grid. Despite having adequate generating capacity to meet their respective standards and surplus for export, the other six companies are net importers of electricity from the grid. These companies are being restructured with a view to improving their financial performance to enable them, among other things, be self reliant in electricity generation with surplus capacity for export to the grid at competitive prices. In addition and given that Kenya is a net importer of sugar there are plans to expand the existing factories to make the country self-sufficient and produce surplus for export, these new developments will provide opportunities for increased cogeneration and reduce reliance on oil fired electricity generation”.
	Section 6.3.2	“Promote cogeneration....in the sugar industry and other commercial establishments where opportunities exist”; “Undertake appropriate studies on co-generation”
	Draft of “Kenya’s Climate Change Technology Needs and Needs Assessment Report” (3 rd Draft, June 2004)	The Ministry of Environment and Natural Resources identify bagasse as a renewable fuel mentioned under Electrical Power Generation Technologies. Under Technology Needs, cogeneration is mentioned as a key option, i.e.: “There is a need to support factories in the adoption of cogeneration”.
	Feed in Tariff Policy	Feed in tariffs introduced for small-hydro, wind and biomass co-generated power
Swaziland	National Communication for the UNFCCC for Swaziland, 2002, Page 12, Section 1.5 (Executive Summary/General Description of steps)	The document mentions electricity generation through cogeneration by the use of high-pressure steam turbines burning bagasse and wood-pulp residue as input fuel.
	Swaziland National Energy Policy (2004)	Chapter 3.3: “The Government is called upon to improve the situation to ensure there are clear guidelines for open access to the national grid” and “The Government is further called upon to investigate and promote efficient and environmentally sound technologies for the utilization of indigenous resources of electricity production”. Bills that will facilitate these previous statements are currently being prepared for Cabinet consideration before being discussed in the two houses of Parliament. In Chapter 3.3.7, issues concerning Independent Power Producers are addressed: “The Government will create an enabling environment to allow the establishment of IPPs as well as support such initiatives”. Finally in Chapter 5.1.4: “Government wants to diversify supply and increase indigenous power generation”.

	National Communication to the UNFCCC for Tanzania, 2003, Table: 3.1: Some GHG Mitigation Options	<p>“Energy Efficiency Improvements: Improve efficiency in existing plants through maintenance, improved steam production and management, improvements to motor drive systems, cogeneration and power factor correction.”</p> <p>“To develop indigenous sources of energy (natural gas, coal, solar, wind, geothermal, hydropower and biomass fuels) to substitute for imported petroleum products.”</p> <p>“To ensure that the existing and expanded supply of energy is environmentally sustainable.”</p>
Tanzania	National Energy Policy of 2003	<p>The energy policy document indirectly supports biomass cogeneration:</p> <p>“Generation of electric power shall be fully open to private and public investors as independent power producers. Investment shall be based on economic and financial criteria considering open access to regional network, balanced domestic supply and environmentally impacts”</p> <p>“Promote efficient biomass conversion and end-use technologies in order to save resources....and minimising threats on climate change”</p>
	EWURA – Electricity and Water Utility Regulatory Authority	Announces feed in tariff for renewable energy sourced power which includes biomass cogeneration
Uganda	Energy Policy for Uganda (2002), Section 1.2.4: New and Renewable Sources of Energy Sub-sector: Biomass	<p>“Diversify power generation sources to ensure security of supply”</p> <p>Priority Policy Action no. 2 (strategic intervention): “Develop selected renewable energy projects e.g. Kakira sugar cogeneration....”</p> <p>Provides pre-determined tariff for electricity generation from small hydro and biomass cogeneration</p>
	National Communication, 2002	<p>“To meet some of the objectives, Government shall employ the following strategies:</p> <p>Promote the use of alternative sources of energy and technologies, which are environmentally friendly.</p> <p>Promote efficient utilisation of energy resources</p> <p>Promotion of private sector participation in the development of both conventional and renewable energy resources”</p>

* Energy Bill received after Council approval Energy Bill received after Council approval

It is clear that supportive policies are crucial to the success of biomass cogeneration. Policies that promote attractive and pre-determined feed-in tariffs and Power Purchase Agreements (PPAs) are particularly important.

A feed-in tariff (FIT) is a policy instrument used to encourage the growth of an industry in renewable energy generation by ensuring that those who produce electricity from solar, wind, biomass and other renewable sources have a guaranteed price for the electricity they produce, and therefore a guaranteed return from their investment. A FIT obliges the utilities responsible for the national grid to purchase electricity from renewable energy sources at a pre-determined (and usually attractive) price. Feed-in tariffs are an important policy incentive for promoting cogeneration as they remove uncertainties regarding the selling price of electricity to the national grid, thus encouraging investors to finance cogeneration plants.

A good PPA must carefully define the commercial operation date. It often includes off-ramp provisions that enable one or both parties to terminate the agreement without penalty. Termination rights require careful negotiation and both parties will want to limit the other party’s right to

terminate. Furthermore, a PPA should carefully define a delivery point at which energy will be sold. The PPA may also require a seller to deliver energy to a specific point on the transmission system, in which case the seller will be responsible for obtaining transmission to the delivery point. Transmission ancillary services, which can be costly, must be specifically allocated in the PPA.

The contract price is also a very important part of a power purchase agreement; this price may be flat or may escalate over time. A PPA should clearly state whether or not Renewable Energy Credits (RECs) are bundled with the sale of electricity. Generally, a seller prefers a PPA that requires selling the project's output only if the project is actually built; a buyer tends to view such a PPA as a "put option" and will insist that a seller makes a binding commitment to build the project. Therefore, the PPA often includes a schedule of certain project milestones and, if a seller fails to achieve a milestone, the buyer may have a right to terminate the PPA, collect damages, or require the seller to post additional credit support.

A PPA may further require a seller to guarantee that a project will meet certain performance standards. For instance, an output guarantee requires a seller to pay a buyer if the output during a specified period fails to meet a minimum level. A PPA often describes circumstances in which either party has a right to curtail output. A PPA's force majeure clause (a common clause in contracts which essentially frees both parties from liability or obligation when an extraordinary event or circumstance beyond the control of the parties occurs, such as a war, strike, riot, crime, flooding, earthquake or volcano prevents one or both parties from fulfilling their obligations under the contract) is very important and distinguishes between events that are "excuses" (which relieve the affected party from the duty to perform), and those that are "risks" (which are allocated to one party or the other) (Northern American Clean Energy 2008).

As mentioned earlier, a number of African countries have adopted or plan to adopt attractive and pre-determined feed-in tariff policies and standard PPAs, and this is likely to result in increased biomass cogeneration development.

Mauritius has, over the years, developed an attractive pricing policy for co-generated power, which has been the key driver for increased production of bagasse co-generated power. The introduction of an attractive FIT for firm power generation was instrumental in promoting biomass cogeneration in Mauritius (Table 9-12). The development of the FIT in Mauritius arose as a result of close collaboration between policy makers, the sugar industry and other stakeholders. The Government played an "honest broker" role in power purchase agreements and setting feed-in tariffs. This shortened the time it took to establish tariffs for cogeneration and avoided what could have been a drawn-out, acrimonious and lengthy negotiation of tariffs (Deepchand 2003). With pre-determined tariffs in place, local and international investors and financiers were willing to develop cogeneration plants.

Promising policy measures are beginning to be implemented in the region, as far as feed-in tariffs are concerned.

Eskom South Africa launched a Cogeneration Programme in 2006, with a target of 900 MW of cogeneration projects, to be achieved within a 5-year window ending March 2011. The programme was in line with the National Electricity Regulator of South Africa (NERSA) initiative to establish a cogeneration framework (guidelines) that will promote new cogeneration projects. Eskom established a cogeneration workgroup to support the initiative and worked jointly with the NERSA and others in industry in developing the project.

One of the key policy/incentive innovations of the programme is that Eskom set a ceiling tariff offer for the cogenerated power, which stipulated that the price should not exceed the ceiling price set by Eskom's avoided cost model, thereby effectively pre-determining the tariff. "Cheapest bids" from technically and commercially qualified bidders would win contracts for up to 15-year durations. A

standard contract/PPA was developed for these cogeneration projects. With these two important ingredients in place (FIT offer and standard PPA), the call for expression of interest (EOI) was a success, and received an overwhelming response, with 5,000 MW worth of EOIs received by the end of September 2007—representing the equivalent of 10% of South Africa’s currently installed capacity.

Table 9-12: Energy pricing in Mauritius

Energy Pricing				
Power mode	Power Plant	Price – Rs (USc)/kWh	Year	Characteristics
Intermittent	Various	0.16 (0.6)	1982	Price frozen since 1982
Continuous	Medine	0.55 (1.9)	1982	No change in price since 1982 –no changes brought to the plant
Continuous	6 IPPs	1.05 (3.7)	1997	44% of kWh price indexed to changes in oil price and the other 56% is fixed
		1.40 (4.9)	2000	
Firm	FUEL	coal - 1.63 (5.7) bag. - 1.56 (5.5)	1985	Invested in new equipment Indexed to coal price
Firm	DRBC	coal - 1.53 (5.4) bag. - 1.46 (5.1)	1998	Invested in second hand equipment Indexed to coal price
Firm	CTBV	both - 1.72 (6.0)	2000	Indexed to coal price, cost of living in Mauritius, foreign exchange rate fluctuations

*The prices for the feed-in tariff indicated in the table allow for the project developers to make an attractive profit. However, the actual profit they make is confidential, and the information is not made public.

Source: Deepchand, 2003

Figure 9-5: Summary of EOIs received: generator net output

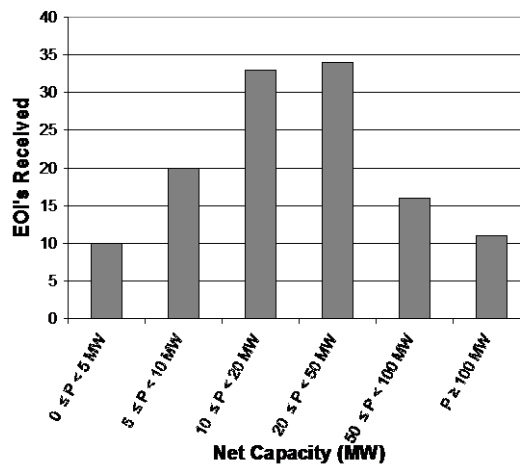

Source: Higgs, 2007

Kenya recently introduced a feed-in tariff policy for wind, biomass (inclusive of co-generation) and small-hydro electricity. The policy is expected to boost exploitation of abundant local renewable energy sources in the country by attracting private sector capital investments in renewables. The policy incentives document defines the pre-determined tariffs (Table 9-13), for both firm and non-firm power, with a more attractive tariff offered for firm power. In addition, the policy defines a window for accessing these initial feed-in tariffs, which would be applicable to the first 100 MW of firm small hydro power and 50 MW of non-firm (continuous) small hydro power; the first 150 MW of

wind power; and the first 150 MW of firm biomass power and 50 MW of non-firm biomass power (Kenya Ministry of Energy 2008).

Table 9-13: Feed-in tariffs in Kenya

Source	Power plant effective generation capacity (MW)	Firm power Tariff (USc/kWh)	Non firm power tariff (USc/kWh)
Small hydro	<1	12.0	10.0
	1-5	10.0	8.0
	5-10	8.0	6.0
Wind	<50	9.0	-
Biomass	<40	7.0	4.5

Source: Ministry of Energy, Kenya, 2008

The FIT was only established in May 2008, but informal consultations with Ministry of Energy officials in Kenya confirm that there has been growing interest from project developers interested in cogeneration since the feed-in tariffs were announced. Uganda and Tanzania have also enacted pre-determined prices for biomass co-generated power, which are likely to stimulate the development of biomass cogeneration.

The key remaining policy challenge is the development of widely acceptable policy guidelines on the sustainable development of biomass cogeneration feedstock and guidelines for ensuring that the benefits of biomass cogeneration trickle down to all those involved in the chain, especially small-scale farmers who are responsible for providing the feedstock.

9.6. FINANCING FOR COGENERATION

The cost of financing a cogeneration plant is normally in the range of US\$1.5 million per MW (RETScreen Undated). This initial set-up cost is significant and many project developers are not able to mobilize the required start-up capital. Both the project developers and financial institutions face various challenges when it comes to financing of cogeneration projects. The main challenge to securing financing is the absence of a standard PPA and pre-determined feed-in tariffs. Once a PPA has been signed and a pre-determined feed-in tariff agreed upon, the project developer is in a stronger position to raise investment finance.

Another major obstacle to mobilising financing for cogeneration projects is the absence of low-cost, long-term financing. This problem is complicated by competition among projects for limited funds and is compounded by unfavourable macro-economic conditions of the countries in sub-Saharan Africa (AFREP/GEF 2005). This becomes even more pronounced for larger-scale cogeneration systems which require a higher amount of financing and, therefore, a larger amount of debt financing. Many commercial banks, especially in Africa, that give typical commercial loans have interest rates between 15 to 20% p.a. and tenors of not more than 5 years (AFREP/GEF 2006; UNEP/GEF 2007). These interest rates are high and the tenures not sufficient for cogeneration investments with project life of 15 to 20 years.

The potential investors in biomass cogeneration projects are either the agro-industries producing the wastes to be used as fuel, or third-party developers (including utilities) with or without joint venture partnership with the agro-industry facility owner. These companies generally lack untied

assets which could be used as collateral for the provision of bank loans. Some may also lack the financial muscle to provide or mobilize guarantee instruments in lieu of asset-based collateral.

Moreover, a number of sugar industries in Africa have higher debt/equity ratios than those normally accepted by banks; therefore, borrowing on their balance sheets would be quite difficult. This is particularly true of state-owned sugar companies whose financial performance is often below par and who are not able to raise the 30% equity normally required by banks (ADB 2008). Sugar companies with significant private sector ownership or which are owned outright by the private sector have a much better financial performance track record, which provides a good basis for balance sheet financing (AFREPREN/FWD 2006; UNEP/GEF 2007).

Small to medium-sized project developers lack the in-house expertise to look for funds, prepare bankable pre-feasibility and feasibility studies, and negotiate with lenders to obtain the most favourable financing terms. The WB-GEF Energy for Rural Transformation (ERT) programme in Uganda has indicated that one of the major problems they face in evaluating the projects applying for ERT financial support is the low quality of proposals received from project proponents and developers. In addition, existing financing schemes usually require a long application and approval procedure that tends to discourage potential developers from pursuing cogeneration investment (AFREPREN/FWD 2006; UNEP/GEF 2007).

Although financial institutions are normally adept at developing financing plans, their knowledge of cogeneration investments is often limited and, therefore, they find it difficult to design the appropriate financing scheme that would suit projects involving biomass energy, as well as construct a credit structure that would be acceptable to all parties involved. The staff who evaluate projects requesting for financing are, in general, not familiar with these technologies. When financing institutions do not have the in-house expertise to evaluate cogeneration projects, the alternative is to hire an external consultant for this purpose. The cost of the consultant is then passed on to the project developer, which inevitably increases the overall financing costs for the project (AFREPREN/FWD 2006; UNEP/GEF 2007).

The general lack of knowledge and familiarity among financial institutions of cogeneration technologies and feedstocks makes them wary of approving loans for cogeneration investments, as they perceive them to be high-risk ventures (Ngigi 2007; Mhango 2005). Although references of projects successfully operating in similar environments are available, such as in Mauritius, very few financiers have visited these projects and have seen them operate successfully.

Biomass cogeneration project developers working on small-scale cogeneration investments often apply for financing for a single investment which may be too small to attract the interest of major financial institutions. Bundling of cogeneration investment opportunities facilitates negotiation of attractive and lower interest rates from the financial institutions by the project developers as it helps realize benefits of economies of scale. Bundling of small-scale cogeneration investments would attract the interest of major financial institutions and development banks and increase the flow of funds to Africa's cogeneration industry (AFREPREN/FWD 2006; UNEP/GEF 2007).

Biomass cogeneration projects are good candidates for Clean Development Mechanism (CDM) financing. Recent analysis indicates that cogeneration projects have a very high approval rate within the CDM, greater than that of many other renewable technologies. However, very few projects in Africa have been able to access CDM funding. Only 3% of registered CDM projects are in Africa, mainly in North Africa and South Africa. In addition, of the registered CDM projects in Africa, only 2 out of 25 have thus far actually been issued Certified Emission Reductions (CERs) (UNEP Risoe Centre 2009).

9.7. TECHNICAL CAPACITY AND RESOURCE ASSESSMENT ISSUES RELATING TO COGENERATION

Although co-generation using biomass has been traditionally practised by sugar factories in Africa, the technologies that are installed are inefficient and do not optimize the use of biomass as a fuel. For many of these factories, the existing cogeneration systems cannot produce enough electricity for their own requirements, and they import electricity from the grid. With the use of modern and efficient cogeneration systems, however, factories can generate enough heat for their process requirements and electricity to meet the factory requirements, as well as for export (AFREPREN/FWD 2006; UNEP/GEF 2007).

Technical know-how, both among the project developers implementing cogeneration projects and the local institutions providing services, is important for the success of the implementation and operation of modern and efficient cogeneration projects. However, there remains a continuing shortage of personnel who are qualified to provide the required expertise and experience. Almost all factories import expertise from Asia and developed countries to undertake feasibility studies, develop their cogeneration projects and implement and operate high-pressure systems (AFREPREN/FWD 2006; UNEP/GEF 2007).

The majority of the components of high-pressure cogeneration systems, apart from civil works, cannot be manufactured in many African countries due to lack of manufacturing capability and facilities. It is estimated that only about 5-10% of the total parts of a cogeneration system could be manufactured locally (AFREPREN/FWD 2006; UNEP/GEF 2007). As a consequence, the capital costs for cogeneration plants are high and the current benefits to the local manufacturing industry are limited. In addition, after purchase of the cogeneration equipment and components, factories in Africa often need to hire expertise from the manufacturer to install and maintain the parts due to limitation in local skills.

The use of biomass waste for cogeneration presents several sustainability challenges. First, inappropriate high-input mono-cropping such as sugarcane plantations can result in the loss of biodiversity, soil fertility and land degradation, and can be accompanied by the use of fertilizers and pesticides, which can lead to pollution of underground and surface water sources. Although this is not directly linked to cogeneration, and is more directly linked to the growth of sugar as a food crop, it is still an issue to be addressed as the expansion of cogeneration is likely to require increased biomass feedstock.

Second, one of the key issues of concern with regard to biomass energy development is the competition for land for food and fuel, especially where expansion of existing estates is required. Some of the options for limiting the competition for land between food and fuel include: (i) increasing food production on current agricultural lands; and (ii) establishment of large bio-energy plantations on low-potential areas and degraded lands that are not currently used for food (Azar and Larson 2000). Prioritization of existing agro-wastes could also avoid the competition for land in the short to medium term in eastern and southern Africa.

9.8. RECOMMENDATIONS

Building on the previous discussion, as well as on available empirical evidence and case studies, implementation of the following recommendations is likely to lead to wider dissemination of cogeneration in Africa:

- **Institution of attractive and pre-determined feed-in tariffs (FITs) and standard Power Purchase Agreements (PPAs) for cogenerated power:** A standard PPA can limit market uncertainty, which stands in the way of substantial investment in biomass cogeneration electricity generation in the region. A PPA, linked to a pre-determined standard-offer or feed-in tariff, from the national utility to purchase all energy produced by biomass cogeneration plants can be instrumental in the successful scaling up cogeneration investments the African power sector (UNEP/GEF 2006).

In India and Brazil, development of feed-in-tariffs has directly increased electricity generation. In India, it has promoted the operation of 506 sugar mills, with a further 100 mills in the pipeline, that produce sell electricity to the grid (WADE, 2004).

- **Innovative Financing:** Innovative financing schemes should be developed by financial institutions in collaboration with project developers. Interaction between financiers and project developers could help bridge the knowledge gap on both sides—financiers would gain a better understanding of cogeneration technologies while project developers would have a better appreciation of pre-requisites for raising financing for cogeneration investments. Bundling of smaller/medium sized projects would help them access funds that have minimum investment caps, and lower the upfront cost of financing.

African countries can tap into the various international and regional initiatives that can provide funding for biomass cogeneration projects. These initiatives include: the Global Environment Facility (GEF) and the Kyoto Protocol's Clean Development Mechanism (CDM). One drawback of the CDM, however, is its high transaction costs and specialized skills requirements that have tended to limit the participation of African countries to date. There are useful lessons to be learnt by African countries from the experience India, China, Brazil and Mexico, on how to expedite CDM cogeneration projects.

- **Innovative Revenue-Sharing Mechanisms:** The benefits of biomass cogeneration should trickle down to the small-scale farmer involved in growing the feedstock. One way of ensuring support for the development of cogeneration is by instituting appropriate revenue-sharing mechanisms similar to the one implemented in Mauritius, where proceeds from the sale of cogenerated electricity are shared equitably among the key stakeholders—including the small-scale farmers who provide sugar cane and other forms of agro-waste to the factories.
- **Sustainable Biomass Feedstock Development:** Regarding the feedstocks for cogeneration, emphasis should be on the use of existing agricultural wastes. Biomass cogeneration projects in Africa should primarily focus on more efficient exploitation of existing agricultural wastes, which presents significant potential without unduly disrupting existing agricultural practices and food production or requiring new land to come into production. Unlike many other agricultural sectors, biomass cogeneration-related waste products (e.g. bagasse) are generated during agro-processing and are rarely returned to the field. Consequently, use of such agricultural wastes for energy generation is unlikely to have a detrimental impact on soil management and food production and could potentially constitute an important additional source of revenue for the poor.

At a later stage, and with sustainability guidelines in place, the development of cogeneration dependent on energy plantations on new land can be assessed. Although useful long-term scenarios of potential conflict between food and biomass energy plantations have been

undertaken, available data is still not fully conclusive. With agricultural practices in Africa being very inefficient, there is substantial biomass energy production potential to be tapped simply through increased productivity on existing lands. Additional research is required to provide a more nuanced and disaggregated understanding of the biomass energy production potential as well as the potential role of cogeneration.

- **High-Pressure Technology and Technology Transfer:** The emphasis should be on encouraging existing agro-industries to adopt high-efficiency cogeneration plants that can efficiently utilize existing wastes to generate electricity for own consumption and sale to the national grid. This can be achieved through the introduction and dissemination of high-pressure advanced cogeneration systems.

The introduction of higher-efficiency cogeneration plants should be coupled with long-term renewable energy training programmes designed to develop a critical mass of locally-trained personnel with the technical, economic and social-cultural skills needed to sustain efficient biomass cogeneration. This was a key factor behind the success of biomass cogeneration in Mauritius. For example, Mauritius was one of the first African countries to introduce a university course for training local engineers in sugar technologies and cogeneration (Deepchand 2003). Over the years, Mauritius has developed a critical mass of experts in cogeneration, and is now actively involved in development of biomass cogeneration in other mainland African countries, such as Tanzania and Uganda. Training should also tackle the preparation of bankable feasibility studies for cogeneration. Study tours and visits to new and existing modern cogeneration plants should be an integral part of the training process in order to provide hands-on experience to project developers.

With an adequate supply of cogeneration experts, many of the barriers, identified in this report, would be overcome. In addition, the cogeneration experts would be able to push for implementation of supporting policy, financing and capacity building measures required for accelerated expansion of cogeneration in Africa. In many respects, the availability of a critical mass of cogeneration experts in Africa is the key to the wider deployment of cogeneration on the continent.

9.9. REFERENCES

- ADB FINESSE, (2006) *Sustainable Production and Consumption of Biomass for Energy in Africa: Subregional Synthesis Report – Eastern & Central Africa*. ADB FINESSE/UNEP/IEA Joint Activity.
- AFREPREN. (2001) *Power Sector Reform in Africa: Proceedings of a Regional Policy Seminar. Occasional Paper No. 5*. Nairobi: AFREPREN.
- AFREPREN. (2002) *African Energy Data Handbook. Occasional Paper No. 13*. Nairobi: AFREPREN.
- AFREPREN. (2003) *African Energy Data Handbook, Occasional Paper No. 23*. Nairobi: AFREPREN.
- AFREPREN/FWD. (2006) *Cogen for Africa FSP (Full Size Project) Brief Final Report*. Nairobi: AFREPREN/FWD.
- Batidzirai, B. (2007) *Outlook on Biofuels in the Southern African Development Community*. Vienna: UNIDO.
- Business Daily. (2008) *Power Providers Eye Thermal Sources to Bridge Energy Gap*. Website (accessed 2 March 2008): <http://allafrica.com/stories/200803311942.html>
- Business Daily. (2007) *Mumias faces up to threats of open markets*. Website (accessed 12 May 2007): <http://www.marsgroupkenya.org/multimedia/?StoryID=175158&page=3>
- Cogen 3. (2003) *Cogen 3*. Pathumthani, Thailand: Cogen 3. Website (accessed 27 July 2009): <http://www.cogen3.net>
- Deepchand K. (2001) *Bagasse-based cogeneration in Mauritius: a model for Eastern and Southern Africa. Occasional Paper No. 2*. AFREPREN: Nairobi.

- Deepchand K. (2002) Promoting equity in large-scale renewable energy developments: the case of Mauritius. *Energy Policy* 30: 1129-1142.
- DEFRA (2005) *Sugar - European Union Regime*. Department for Environment, Food and Rural Affairs: London. Website (accessed 29 July 2009): <http://www.defra.gov.uk/FARM/crops/sugar/eu/>
- Du Preez, G. (2005) South Africa sows crops to energy seeds. *Engineering News*, 5 December, 2005.
- Earthlife Africa/SECCP. (2003) NGO Forum "Turning Policy into Reality: from the ground up". Website (accessed 20 July 2009): www.gefweb.org/Partners/partners-Nongovernmental_Organ/documents/NGO_forum_report_Oct.26.06.pdf
- Ekouevi K. (2001) An Overview of Biomass Energy Issues in sub-Saharan Africa. *Proceedings of the African High-Level Regional Meeting on Energy and Sustainable Development, for the Ninth Session on the Commission on Sustainable Development, UNEP Collaborating Centre on Energy and Development, Denmark*.
- EIA (2004) *Table 6.4, World Electricity Installed Capacity by Type, January 1, 2004*. Washington DC: EIA. Website (accessed 27 July 2009): www.eia.doe.gov/pub/international/iea2004/table64.xls
- Energy in Africa. (2007), http://www.energyinafrica.net/news/oil_gas/622455.htm
- Engorait, S.P. (2004) *HBF Cogeneration Study: Uganda*. Nairobi: AFREPREN.
- Engorait, S.P. (2003) Meeting the Challenges of Increased Private Sector Investments and Increased Access. *Updated 3rd Draft Research Report, Energy Sector Reform Theme Group*. Nairobi: AFREPREN.
- FAO. (2000) Rural Energy Supply. *Environment and Natural Resource Working Paper*. Rome: FAO.
- FAO. (2003) *Wood Energy*. Rome: FAO. Website (accessed 20 July 2009): <http://www.fao.org/forestry/FOP/FOPH/ENERGY/databa-e.stm>
- FAO. (2007) *Sustainable Wood Energy Systems*. Rome: FAO. Website (accessed 20 July 2009): <http://www.fao.org/forestry/foris/pdf/infonotes/infofaoenglish-sustainablewoodenergysystems.pdf>
- FAO/ADB. (1995) *Future Energy Requirements for Africa's Agriculture*. Rome: FAO.
- FAO (2004) www.fao.org/WAICENT/FAOINFO/ECONOMICS/ESS/compendium_2003/default.asp.
- Ghiorgis, W. (2002) *Renewables and Energy for Rural Development Theme Group: Country Data and Statistics—Ethiopia*. African Energy Policy Research Network (AFREPREN/FWD), Nairobi.
- Goldemberg J. (2003) The Case for Renewable Energy. *Thematic Background Paper for the Renewables 2004 Conference*
- Gueye, M.K. (2006) *Sustainable Bio-Energy: Challenges and Opportunities*. Panel Presentation at the Bonn Conference. Website (accessed 27 July 2009): http://www.globalproblems-globalsolutions-files.org/unf_website/PDF/unf_bonn_conference.pdf
- Gwang'ombe, F. (2004) *Renewable Energy Technologies in Tanzania: Biomass-Based Cogeneration*. Nairobi: AFREPREN/FWD.
- Hall D.O. and Mao, Y.S. (1994) *Biomass and Coal in Africa*. London: Zed Books.
- Hall D.O. and Rosillo-Calle (1998) Evaluating Environmental Effects and Carbon Sources and Sinks Resulting from Biomass Production and Use in Developing Countries. In *Biomass: Data Analysis and Trends*. Paris: OECD/IEA, pp.293-314.
- IEA. (1998) *World Energy Outlook 1998*. Paris: IEA.
- IEA. (2000) *World Energy Outlook 2000*. Paris: IEA.
- IEA. (2002a) *Energy Balances of Non-OECD Countries, 1999-2000*. Paris: IEA.
- IEA. (2002b) *World Energy Outlook 2002*. Paris: IEA.
- IEA. (2003) *Energy Balances and Statistics for Non-OECD Countries, 2000-2001*. Paris: IEA.
- IEA. (2004a) *Energy Balances of Non-OECD Countries, 2001-2002*. Paris: IEA.
- IEA. (2004b) *World Energy Outlook 2004*. Paris: IEA.
- IEA. (2004c) *Biofuels for Transport: An International Perspective*. Paris: IEA.
- IEA. (2007) *World Energy Statistics*. Paris: IEA. Website (accessed July 20 2009): <http://www.iea.org/Textbase/stats/index.asp>
- IEI. (2001) *Energy for Sustainable Development, Volume 5(1)*. Bangalore, India.
- IFC. (2008) *African Infrastructure Country Diagnostic (AICD) Study*. Washington, DC: IFC.
- Kaleyesus, B. (2007) Ethiopia looks for biofuel as alternative energy resource. *Alexander's Gas and Oil Connections—News & Trends: Africa* 12(16): Website (accessed 20 July 2009): <http://www.gasandoil.com/goc/news/nta73735.htm>
- Karekezi S. and Ranja T. (1997). *Renewable Energy Technologies in Africa*. London: Zed Books.

- Karekezi S. *et al.*, (eds.) (2002) Africa: improving modern energy services for the poor. *Energy Policy Journal* 30: 1015-1028.
- Karekezi, S. and Kithyoma, W. (eds.) (2005) *Sustainable Energy in Africa: Cogeneration and Geothermal in the East and Horn of Africa – Status and Prospects*. Nairobi: AFREPREN.
- Kyalo, J.M. (1992) Firm's Efforts Praised. *Daily Nation*, Nairobi.
- MOEPD (Ministry of Energy and Power Development) (2007) The National Biodiesel Feedstock Production Programme, Zimbabwe. Website (accessed 20 July 2009): <http://www.energy.gov.zw/renewableenergy/Biodiesel.htm>
- Holmes, W.H. (2008) *Brief Anatomy of a Geothermal Power Purchase Agreement*. Portland: Stoell Rivers LLP. Website (accessed 20 July 2009): <http://www.stoel.com/showarticle.aspx?show=3452>
- Nyoka, B. I. (2003) State of Forest and Tree Genetic Resources in Dry Zone Southern Africa Development Community Countries. *Forest Genetic Resources Working Paper FGR/41E*. Rome: FAO.
- Reddy K.N., Williams R.H. and Johansson T.B. (1997) *Energy After Rio: Prospects and Challenges*. New York: UNDP.
- Rediff News (2008) Govt to bear 80% cost of generating solar power. New Delhi: Rediff News. Website (accessed 20 July 2009): <http://in.rediff.com/money/2008/jan/03power.htm>
- RETScreen International (undated). *Clean Energy Project Analysis Course, Combined Heat and Power Project Analysis*. RETScreen International. Website (accessed 27 July 2009): http://www.retscreen.net/download.php/da/288/1/RETScreen4_overview_CHP.ppt
- Republic of Uganda (2006) *Background to the Budget 2006/07 Fiscal Year*. Website (accessed 20 July 2009): http://www.finance.go.ug/docs/BTTB_06%20Final.pdf
- Republic of Uganda (2007) Renewable Energy. Website (accessed 20 July 2009): <http://www.energyandminerals.go.ug/renenergy/Renewable%20Energy%20Source.html>
- Reuters (2006) SA company says it will make biodiesel from algae. Motoring News. Website (accessed 20 July 2009): <http://www.motoring.co.za/index.php?fArticleId=3566349>
- SADC TAU (1997). *FINESSE Activities in the SADC Region: Zimbabwe Country Study*. Luanda: SADC/UNDP.
- Sudan Development Programme (2007) Website: <http://www.sudandevlopmentprogram.org/sp/news/news493.htm>
- Takavarasha, T., Uppal, J. and Hongo, H. (2006) Feasibility Study for the Production and Use of Biofuel in the SADC Region. Gaborone: SADC.
- TaTEDO (2006) Potential of Liquid Biofuels for Transport in Tanzania, *TaTEDO Magazine* 4.
- Thom, C. and Banks, D.I. (1994) Biogas as a rural domestic energy source: a pilot study. *Journal of Energy R&D in Southern Africa* 5(4): 121-125.
- U. S. Environmental Protection Agency (2007) *Biomass Combined Heat and Power Catalogue of Technologies Combined Heat and Power Partnership*. Washington, DC: US-EPA.
- UFH (University of Fort Hare) (2007) *Implementation, Evaluation and Performance Monitoring of a Biomass Gasifier*. <http://www.ufh.ac.za/fhit/>
- UNDESA. (2007) *Small-Scale Production and Use of Liquid Biofuels in Sub-Saharan Africa: Perspectives for Sustainable Development*. New York: UNDESA.
- UNEP Risoe Centre (2009) *CDM Projects by Host Region*. Roskilde, Denmark: UNEP-Risoe Centre. Website (accessed 2 July 2009): <http://www.cdmpipeline.org/cdm-projects-region.htm#6>.
- United Nations. (2006) *The Emerging Biofuels Market: Regulatory, Trade and Development Implications*. Geneva: UNCTAD..
- United Nations Statistics Division. (2005) *Progress Towards the Millennium Development Goals, 1990-2005: Goal 1. Eradicate Extreme Poverty and Hunger*. Website (accessed 20 July 2009): http://mdgs.un.org/unsd/mdg/Resources/Attach/Products/Progress2005/goal_1.pdf
- Veragoo D. (2003) Cogeneration: The Promotion of Renewable Energy and Efficiency in Mauritius. *Paper presented in the Regional Consultative Meeting on REEEP in East Africa, 9-10 June 2003*. Nairobi: AFREPREN/FWD.
- WADE. (2004) *Biomass Cogeneration – Global Review and Potential*. Edinburgh: WADE.
- Winrock International. (2002) *Trade Guide on Renewable Energy in Brazil*. Washington, DC: Winrock International.
- Wolde-Ghiorgis, W. (2002) Renewable energy for rural development in Ethiopia: the case for new energy policies and institutional reform. *Energy Policy* 30: 1095-1105.
- World Bank. (2000) *World Development Report, 2000*. Washington DC: World Bank.
- World Bank. (2003) *African Development Indicators, 2003*. Washington DC: World Bank.

- World Bank. (2003) *World Development Report, 2003*. Washington DC: World Bank.
- World Bank. (2005) *World Development Report, 2005*. Washington DC: World Bank.
- Wudine, Z. (2007) *Ethiopia's New Energy Strategy Opens Way for Bio-Fuel*. Website (accessed 20 July 2009): <http://www.geocities.com/akababi/bionov07041.htm>
- Yamamoto Y., Fujino J., and Yamaji K. (2001) Evaluation of Bio-energy Potential with a Multi-Regional Global-Land-Use-And-Energy Model. *Biomass & Bio-energy* 21: 185-203.
- Yuko, D. N., Ogwayo, A.W., Litondo, J.M. and Misango, Q.B. (2003) *Revitalising the Sugar Industry, Strengthening the Power Sector: Putting the Sweetness Back into the Sugar Industry – Electricity Generation from Sugarcane Residual Fuels*. Nairobi: M & E Consulting Engineers.

10. BAGASSE COGENERATION IN MAURITIUS: POLICY LESSONS FOR AFRICAN COUNTRIES

By Prakash Deenapanray

UNDP Mauritius

Contact: prakash.deenapanray@undp.org

10.1. ABSTRACT

This chapter reviews the evolution of bagasse cogeneration in Mauritius and discusses a number of policy instruments that have been used to support its development, including planning and regulatory paths, financial and tax incentives, power purchase agreements (PPAs), research and development as well as equity participation. The use of bagasse in the generation of electricity has had a pronounced contribution in reducing the emissions of CO₂ in Mauritius. The paper also considers the possibility of replicating the experience of Mauritius in other African countries by specifically looking at the case of Mozambique. From this analysis, it is suggested that the Clean Development Mechanism (CDM) represents a powerful tool to promote bagasse cogeneration in the developing world.

10.2. INTRODUCTION

Mauritius is one of the few countries in the world that can boast of a relatively high share of renewable energy sources in its electricity mix. In a typical year, around 21-23% of the country's electricity is generated from renewable energy, with hydro-electricity and bagasse contributing roughly 2-4% and 19-21%, respectively. This paper focuses on the policies and policy instruments that have been critical in the development of bagasse as an electricity generation source in Mauritius. These policies and instruments have had significant positive impacts on the reduction of greenhouse gases (GHGs), as well as other pollutants. It is proposed that similar policies and instruments could be applied in other African countries. Mozambique is used as a case study.

10.3. ELECTRICITY GENERATION IN MAURITIUS

The generation of electricity has grown by 5-6% annually over the past decade in order to match demand (see Figure 10-1), reaching 2,465 GWh in 2007. Thermal energy currently generates 96.6% of this electricity and hydro/wind the remaining 3.4%.

Bagasse, a renewable source of biomass obtained after sugar cane is crushed to extract its juice, accounted for 19% of total electricity generation (and 23.8% of thermal generation) in 2007. Fossil fuels, such as coal (40.3%) and heavy fuel oil (37.3%), accounted for 77.6% of electricity generation. The combination of hydro and bagasse meant that the share of renewable energy in the electricity mix of Mauritius was 22.4% in 2007. In Mauritius, electricity is consumed in roughly equal proportions by commercial, industrial and domestic activities.

Figure 10-1: Electricity generated in Mauritius, 1980-2007

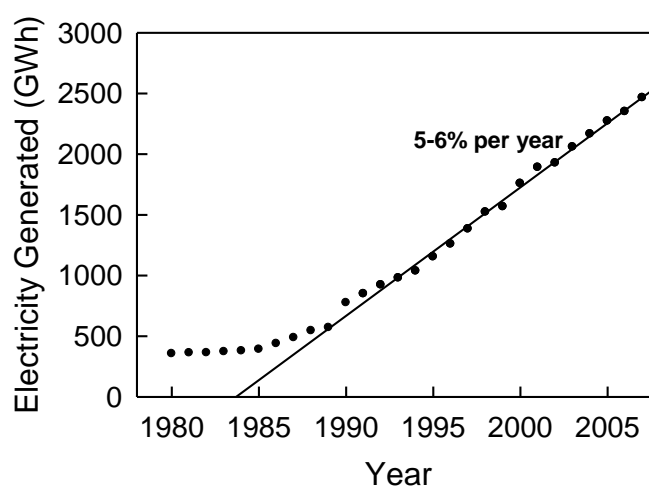

Source: Energy Statistics 1980 to 2007, Central Statistics Office

10.3.1. BAGASSE COGENERATION

Sugar cane is a major, commercially-grown agricultural crop found in the vast majority of countries in Africa. A C-4 species, sugar cane has one of the highest photosynthetic biomass conversion efficiencies of all crops, able to fix around 55 tonnes of dry matter per hectare of land cultivated on

an annually renewable basis. Table 10-1 shows the observed overall conversion efficiencies from solar energy to chemical potential energy contained in the resulting biomass of several plants. Natural annualised efficiencies of these plants range from 0.2 to 3.0%, with tropical sugar cane displaying conversion efficiency as high as 2.59% (Klass, 2004).

Table 10-1: Overall conversion efficiency from solar energy to biomass of selected crops.

	Switchgrass	Corn	Willow and Poplar	Tropical Sugarcane	Tropical Napier Grass	Tropical Tree Plot
Conversion Efficiency (%)	0.22 – 0.56	0.79	0.30 – 0.41	2.24 – 2.59	2.80	0.95

In Mauritius, between 4 and 5 million tonnes of cane are harvested annually (CSO 2007). After the cane is crushed to extract its juice, the fibrous fraction of the remaining cane stalk is known as bagasse. The bagasse is composed of 50% fibre, 48% moisture and 2% sugars (Ramjeawon 2008), and it is burnt to generate heat and electricity – i.e. for cogeneration. The heat and electricity is used first to meet the energy requirements of the sugar factory, and any additional electricity is fed into the national grid. In this context, the entity involved in cogeneration also operates as an Independent Power Producer (IPP), and is able to sell excess electricity to the grid through a Power Purchase Agreement (PPA) with the public utility—the Central Electricity Board—managing the Mauritian grid.

Bagasse cogeneration was in many respects pioneered in Mauritius and, as early as 1926-27, 26% of electricity generated in Mauritius was in sugar factories (WADE 2004). At this time, electricity was produced during only the sugar cane harvest season – i.e. only during part of the year. In this mode of operation, electricity generation is referred to as “continuous power” (as opposed to “firm power”). Although continuous power contributes positively to broaden the electricity mix of Mauritius, its seasonal character implies that there should be an equivalent power generation backup capacity held by the public utility. This is obviously not a desirable condition for the public utility, and it would be better for the cogenerator to provide firm power – i.e. reliable power throughout the year – to the electricity grid.

An example serves to demonstrate the operation of a modern bagasse cogeneration power plant in Mauritius. The latest bagasse cogeneration plant co-firing with coal—Compagnie Thermique de Savannah (CTSAV)—was commissioned in 2007. During the crop season, which typically runs between June and November each year, CTSAV burns approximately 350,000 tonnes of bagasse obtained from the processing of around 1.2 million tonnes of cane at the adjacent Savannah Sugar Factory (SSF). It exports 65 MW into the grid, while at the same time supplying 9.5 MW and 140 tonne/hr of low-pressure steam to SSF. During the inter-crop period when bagasse is not available, the plant burns around 170,000 tonnes of coal, and a net export of 74 MW into the national grid is ensured. CTSAV generates around 500 GWh of electricity annually. While the power plant has an electrical efficiency of around 40-45%, it has a high thermal efficiency of ~85%.

Figure 10-2 shows the change in electricity generated per tonne of bagasse between 1990 and 2007. In general, there has been an increase in the electricity output per tonne of bagasse burnt, revealing an increase in the efficiency of electricity output from bagasse cogeneration. In 2007, the electricity generated was around 445 kWh/tonne bagasse, which corresponds to ~110 kWh/tonne cane crushed (or 110 kWh/TC).

One of the main technological improvements leading to higher efficiency has been the use of high-pressure boilers. For instance, the two most recently built bagasse cogeneration power plants operate at a boiler pressure of 82 bars (producing superheated steam at 525°C), as opposed to older

facilities operating at boiler pressures between 31 and 44 bars. Efficiency gains, leading to a surplus of electricity generation for export into the grid, have also been accomplished through the use of the turbo-alternator and the optimisation of other process parameters, including process steam consumption, increasing fibre content of cane through genetic manipulation, lower moisture content of bagasse, and reducing the electricity consumption in the sugar mill and in the power plant (Lau *et al.* 2005).

Figure 10-2: Electricity generated from bagasse, 1990-2007

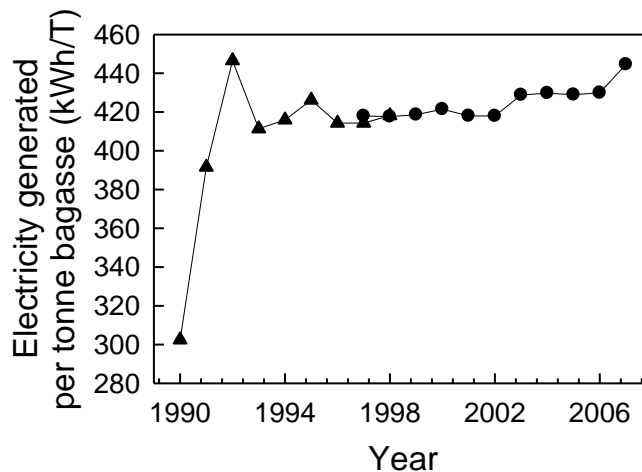

Source: Energy Statistics 1980 to 2007, Central Statistics Office

Further, the development of bagasse cogeneration has been promoted by providing incentives for the cogenerator to export firm power onto the grid – i.e. electricity throughout the year and not just during the crop season. In an effort to shift from continuous to firm power generation, and in the absence of other renewable biomass in Mauritius, bagasse cogeneration projects co-firing with coal have been developed to ensure year-round operation (see the example of CTSAV above).

Figure 10-3 shows the ratio of firm to continuous electricity produced in Mauritius between 1997 and 2007. The trend reveals a clear shift towards the generation of firm power.

Figure 10-3: Ratio of firm to continuous power, 1997-2007

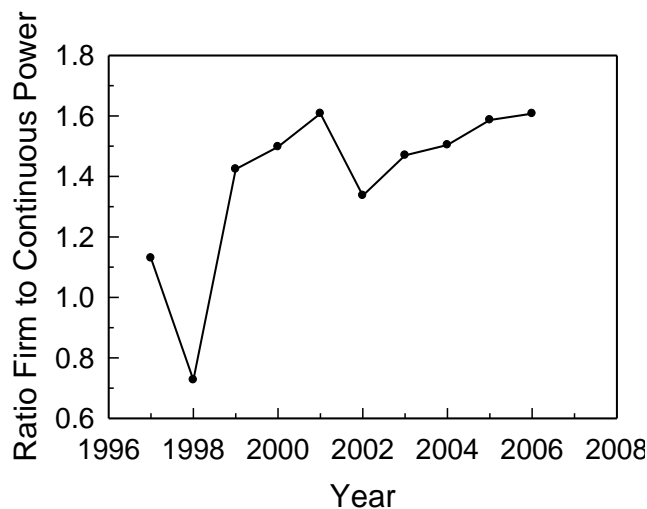

10.3.2. DEVELOPMENT OF COGENERATION IN MAURITIUS

Several policies have been put in place since the early 1970s to enhance the efficiency and financial viability of the sugar sector in Mauritius. The history of bagasse cogeneration in Mauritius has been previously reported (Deepchand 2005, 2001). This section provides an overview of the main policies and related instruments pertaining to the development of bagasse cogeneration, rather than the sugar industry in general. Similar measures have also been applied in larger countries producing sugar, and hence bagasse, including Brazil, India and the Philippines (WADE 2004).

The policies and instruments discussed below have to be considered while bearing in mind the evolution of the world sugar market and the significant economic growth that Mauritius has witnessed over the past three decades. These circumstances have been the main drivers underlying the increase in efficiency of bagasse cogeneration in Mauritius. Recently, there have been significant global changes that have eroded the preferential tariff that Africa-Caribbean-Pacific (ACP) countries benefited from for their sugar under the Sugar Protocol of the European Union. These changes have imposed the re-structuring of the sugar industry into a cane industry in Mauritius, which embraces the concept of 'clustering' that further promotes the use of sugar cane by-products, including bagasse.³⁴ The drivers of reforming the sugar industry, as well as the broad architecture of the cane industry, are discussed first.

REFORM OF THE SUGAR CANE INDUSTRY

Until recently, the revenue under the Sugar Protocol has provided a stable and predictable level of earnings for Mauritius. However, under Article 20 of the World Trade Organisation (WTO) Agreement on Agriculture, countries adopted the Doha Declaration which, with regard to agriculture, agreed to establish a fair and market-oriented trading system through a programme of fundamental reform. The WTO Framework Agreement of 1 August 2004 ended all forms of export subsidies in all sectors (including sugar) and imposed reductions in import tariffs, both of which have resulted in a substantial reform of the EU Sugar Regime. Such reforms are intended to phase out all export subsidies and introduce substantive reductions in domestic support, meaning that ACP countries will lose their established preferential tariffs for the export of sugar to the EU. This measure will affect the export of approximately 5.1 million tonnes of sugar by ACP countries and India.

The current costs of sugar production in Mauritius are such that Mauritius will not be able to be a cost-competitive supplier in the new market environment, with its preferential tariff removed. Unless the costs of production in the sugar industry are substantially brought down and other avenues explored through rapid diversification within the sugar cane cluster, the Mauritian economy will face significant problems. In such a context, Mauritius has no option but to undertake major reforms to improve its competitiveness. In order to achieve this, emphasis has been placed on developing a cane industry around the clustering of sugar production, including refining of sugar, the production of special sugars (e.g. organic) and the production of cane co-products, including bagasse cogeneration on a firm power basis, the production of ethanol and Rhum Agricole (Anonymous 2005).

³⁴ Traditionally, raw sugar was the most important commodity derived from sugar cane. Under the clustering concept, value-added activities related to the refining of raw sugar, production of bio-ethanol through the distillation of either molasses or cane juice are being promoted. Increasing the energetic value of cane as well as the efficiency of co-generation also form an integral part of this approach.

In this context, the contribution of bagasse cogeneration is expected to increase over the coming years. By 2015, independent power plants located in sugar factory sites are expected to export some 1,700 GWh of electricity. The optimal burning of bagasse in power plants with 82 bar boilers and condensing/pass-out turbo alternators would yield some 700 GWh. In normal circumstances, some 1,100 GWh would come from coal (Deenapanray 2006).

PLANNING AND REGULATORY PATHS

In 1988, the Government of Mauritius promulgated the Sugar Industry Efficiency Act (SIEA) with the objective of providing for an efficient and viable sugar industry while seeking to promote agricultural diversification and diversification within the sugar sector – i.e. maximising the usage of by-products of sugar, including bagasse. The SIEA culminated in a partnership between the Government and the private sector to initiate a bagasse energy development programme (BEDP) with the primary objective of optimising the use of by-products in the sugar industry, including bagasse cogeneration for electricity production as a priority. This partnership brought about an improved business environment for the sugar sector. In 1990, the industry presented a programme of investment of the order of US\$130 million for sugar factory rehabilitation and modernisation, irrigation and diversification, of which around US\$27 million was designated for bagasse saving and handling operations, and expansion of the industry’s capacity to generate electricity and abate pollution, especially the emission of particulate matter.

FINANCIAL AND TAX INCENTIVES

The SIEA also introduced a system of performance-linked export duty rebates wherein incentives were provided for the enhanced use of bagasse for electricity production. In parallel, amendments to the Income Tax Act provided incentives to save energy in cane processing and use bagasse to produce electricity.

POWER PURCHASE AGREEMENTS

One of the critical elements in the development of bagasse co-generation in Mauritius has been the pricing of electricity. Typically, the price (per kWh) at which the Central Electricity Board purchases electricity from an Independent Power Producer, in addition to other contractual agreements, is set out in a Power Purchase Agreement (PPA). Thus far, PPAs have provided long-term (20 year) security to the price of electricity available to the IPP. The price of bagasse co-generated electricity can be calculated on the basis of “avoided cost” for an equivalent firm power plant that would otherwise have been commissioned by the public utility. Also, in order to protect the IPP against fluctuations in foreign exchange (in case the IPP has taken a loan for debt financing in hard currency and coal is also purchased in hard currency), the price of electricity may be indexed to foreign exchange fluctuations, or changes in the cost of coal.

RESEARCH & DEVELOPMENT

The Mauritius Sugar Industry Research Institute (MSIRI) is a centre of excellence that carries out research on various aspects of sugar cane production. The activities of MSIRI are financed by a cess (tax) levied on sugar produced by all Mauritian cane growers. Research has focused on increasing productivity in field operations, such as mechanisation, de-rocking of lands and improved irrigation techniques to optimise the use of water, as well as on the introduction of high-yielding cane varieties.

MSIRI is also working to engineer high-fibre cane that performs better as an energy crop. In 2006, a new cane variety having a high fibre content of 23% (as opposed to 19-20% for conventional cane)

was released (Autrey 2007). The desire to increase the fibre content of cane at the expense of reducing its brix (i.e. content of juice) is an economically viable proposition because any extra bagasse produced will displace imported, and more expensive, coal.

Also, modern sugar factories are being built to operate in a “flexi mode” where—depending of the relative prices of ethanol and sugar—cane juice can either be distilled to produce ethanol or processed to produce sugar.

Another feature of research is to use cane trash (renewable biomass) as an additional fuel in bagasse-coal co-firing. In the future, the role of MSIRI will be to focus on the sugar cane cluster concept (as opposed to its traditional role centred around sugar productivity). An amount of Rs 500 million (i.e. ~US\$15-16 million) has been earmarked for the 2005-2015 period for such research and development.

EQUITY PARTICIPATION

As part of Government policy to broaden ownership in the sugar industry, small planters and employees hold 20% of the share in milling companies, as well as holding a stake (10%-20%) in cogeneration plants, through the Sugar Investment Trust (SIT). In order to foster a sense of ownership and participation in the reform process, the following measures have been proposed: an increase of the share of planters in power companies over and above the share of SIT; an increase of the bagasse transfer price for small planters; providing at least 25% equity participation of ethanol companies to small planters and sugar cluster employee; and a possible increase of the share of SIT in the equity of milling companies.

10.4. CARBON DIOXIDE EMISSION REDUCTIONS

As discussed earlier, the trend in bagasse cogeneration in Mauritius is for co-firing with coal. Since bagasse is not stored, all of it is burned during the crop season, and the difference in electricity generation commitment to the public utility is met by burning coal. Outside of the harvest season, all electricity from cogeneration plants is generated from coal. Over the course of a year, bagasse and coal would typically represent about 35% and 65%, respectively, of electricity production (Deenapanray 2006). In order to meet demand for electricity, the trend in Mauritius has been a switch in favour of coal, and away from heavy fuel oil. For the purposes of calculating the CO₂ emission reduction arising from burning bagasse to generate electricity, the grid emission factor of Mauritius has been calculated using the ‘CDM tool to calculate the emission factor for an electricity system’. For 2007, the grid emission factor for Mauritius was 1.1773 tCO₂/MWh. Using existing technology in Mauritius, avoided CO₂ emissions in 2007 were around 408,300 tonnes. If all bagasse were burned at the average efficiencies of 374.6 kWh per tonne of bagasse (kWh/TB), avoided emissions in 2007 would have been around 630,705 tonnes of CO₂.

10.4.1. PROSPECTS OF REPLICATION IN AFRICAN COUNTRIES

Since several African countries grow sugar cane, there is the potential to replicate the successful experience of Mauritius in electricity generation from bagasse. A study published in 2005 estimated that the potential for generating around 10,000 GWh/year (or 10 TWh) from around 90 million tonnes of cane existed in Africa when considering the conversion efficiency achieved in Mauritius (Deepchand 2005). To place this into perspective, the demand for electricity in Africa was around 533 TWh in 2005 (EIA 2008).

Many African countries have the added advantage of potentially being able to use a renewable biomass, instead of coal, for co-firing with bagasse in order to generate firm power. Also, the development dividends in African countries can be substantially higher than in Mauritius: since bagasse cogeneration can be applied as a decentralised technology, it is well adapted for rural electrification. Bagasse cogeneration could therefore play a significant role in achieving the Millennium Development Goals, especially in the least developed African countries. It should be noted that the combustion of bagasse (or other biomass residues) could also be used to generate only thermal energy for industrial processes, thereby displacing the use of fossil fuel. Being solid fuels, biomass residues are more amenable to substitute coal than fuel oil or natural gas.

As an example, the potential to generate electricity from bagasse, and hence reduce GHG emissions, is calculated for Mozambique using the average conversion efficiency achieved in Mauritius for two power plants (CTBV and CTSAV), which operate at a boiler pressure of 82 bars.

On average, these two power plants generate 374.6 kWh per tonne of bagasse (kWh/TB). In 2007, Mozambique produced 596,271 tonnes of bagasse. With a conversion efficiency of 374.6 kWh/TB, 223.4 GWh of electricity could be produced each year. If all of this bagasse were used to generate electricity instead of using natural gas (as a conservative baseline), this would result in the annual reduction of around 53,500 tonnes of CO₂. If electricity were generated from diesel in the baseline scenario, the annual reduction of CO₂ would then be around 59,600 tonnes.

In the case of co-firing with a renewable biomass, the potential for greenhouse gas emission reductions could be much higher, thereby further increasing the revenues from CDM as discussed below. However, it should be noted that if the electricity generated were fed to the grid, then the emissions reduction would be only around 10,000 tCO₂/yr since Mozambique has a very low grid emission factor.

However, there are numerous barriers that still stand in the way of widespread development of bagasse (or biomass) co-generation in Africa. The Clean Development Mechanism (CDM) is one instrument that can be used to overcome these barriers as discussed below.

10.4.2. THE CLEAN DEVELOPMENT MECHANISM (CDM)

The CDM provides a financial incentive for developing countries to host projects that reduce GHG emissions. The carbon credits that are generated can be sold to an Annex 1 country that has a binding greenhouse emission reduction target under the Kyoto Protocol. A parallel objective of the CDM is to facilitate the transfer of “cleaner” technologies to the developing countries, thereby assisting their sustainable development.

A large number of biomass cogeneration projects have benefited from the CDM, notably in Brazil and India. Typically, projects would use the approved consolidated baseline and monitoring methodology ACM0006, ‘Consolidated methodology for electricity generation from biomass residues – Version 8’. Further, there are several small-scale methodologies (e.g. categories I.A, I.C, and I.D) under which renewable biomass projects could generate carbon credits.

In Africa, the CDM could provide the incentive required to upgrade or install cogeneration equipment in sugar mills in a cost-effective manner. Another advantage present in African countries seeking to develop CDM projects related to biomass cogeneration is the fact that most similar CDM registered projects have justified additionality using barrier analysis. A combination of, but not exclusively, the following barriers, which may be applicable to African countries, have been invoked: investment barrier, technological barrier, barrier due to prevailing practice, institutional barriers (e.g. access to the grid), price risk of biomass residue, and biomass collection and storage barriers. A few projects have demonstrated additionality by showing that biomass co-generation was not the least-cost method (i.e. financially additional), in conjunction with barrier analysis.

Taking the case of Mozambique, and assuming a price of Euro 10 for 1 tonne of CO₂ reduced, the maximum potential for CDM revenues compared with the case when power is generated from natural gas would be Euro 535,000 per annum.

It is important to note that, along the same lines as the proposed use of cane trash as a combustible input in electricity generation in Mauritius, African countries, in addition to renewable woody biomass, could also maximise the use of agricultural trash to produce clean electricity (GCEP 2005).

10.5. CONCLUDING REMARKS

This paper has reviewed the evolution of bagasse co-generation in Mauritius, and has discussed a number of policy instruments that have been used to support its development. The use of bagasse in the generation of electricity has had a pronounced contribution in reducing the emissions of CO₂ in Mauritius. The paper has also looked at the possibility of replicating the experience of Mauritius in other African countries by specifically looking at the case of Mozambique. The Clean Development Mechanism represents a powerful tool to promote bagasse cogeneration in the developing world.

10.6. REFERENCES

- Anonymous. (2005) *Preserving the Sugarcane Industry in the 21st Century: A Roadmap Presented*. Business Magazine. Website (accessed 15 December 2005): <http://www.businessmag.mu/displayNewsContent.asp?NID=6967&CID=21>
- Autrey, J.C. (2007) *Analyse de la récolte sucrière 2006 et de la performance variétale. Homologation d'une nouvelle variété de canne à sucre à teneur en fibre améliorée - événement marquant dans la production bioénergétique à Maurice*. Redit: Mauritius Sugar Industry Research Institute
- CSO. (2007) *Digest of Agricultural Statistics—2007*. Port Louis: Central Statistics Office. Website (accessed 19 December 2008): <http://www.gov.mu/portal/goc/cso/report/natacc/agri07/sugar.pdf>
- Deenapanray, P.N.K. (2006) *Synthesis Report on Renewable Energy*. Port Louis: Mauritius Research Council. Website (accessed 14 February 2009): <http://www.mrc.org.mu/Projects/REReport.pdf>
- Deepchand, K. (2005) *Sugar Cane Bagasse Energy Cogeneration—Lessons from Mauritius*. Paper Presented to the Parliamentarian Forum on Energy Legislation and Sustainable Development, 5-7 October 2005, Cape Town, South Africa. Website (accessed 23 December 2008): www.un.org/esa/sustdev/sdissues/energy/op/parliamentarian_forum/deepchand_bagasse.pdf
- Deepchand, K. (2001) *Bagasse-based cogeneration in Mauritius—a model for Eastern and Southern Africa. African Energy Policy Research Network, Report No. 272*.
- EIA (2008) Chapter 5—Electricity. *The International Energy Outlook 2008*. Washington DC: Energy Information Administration, Website (accessed 15 April 2009): <http://www.eia.doe.gov/oiaf/ieo/electricity.html>
- GCEP (2005) *An Assessment of Biomass Feedstock and Conversion Research Opportunities*. Global Climate and Energy Project, Energy Assessment Analysis. Palo Alto: Stanford University.
- Klass, D. (2004) Biomass for renewable energy and fuels. In *Encyclopedia of Energy*. Oxford: Elsevier.
- Lau, A.F., K.T.K.F. Kong Win Chang and D. Gunness (2005) An integral approach to evaluate the performance of bagasse cogeneration plant. *International Sugar Journal* 107: 435-440.
- Ramjeawon, T. (2008) Life cycle assessment of electricity generation from bagasse in Mauritius. *Journal of Cleaner Production* 16: 1727-1734.
- WADE (2004) *Bagasse Cogeneration – Global Review and Potential*. Edinburgh: World Alliance for Decentralized Energy.

11. ENVIRONMENTAL AND ECONOMIC BENEFITS OF BIOMASS FUEL USE IN CEMENT PRODUCTION

By Yared Haile-Meskel

Industrial Consultant

Contact: yarhm@aol.com

11.1. ABSTRACT

With the growing realisation of the impact of fossil fuels on climate change, there is a renewed interest in the utilisation of biomass as a renewable and carbon-neutral energy source. This chapter reviews the use of biomass in clinker production in the cement industry, which is one of the largest sources of GHGs. The chapter reports experiences of different countries that are using biomass and non-renewable waste fuels in cement production plants. The technology of preparation, feeding, and burning of biomass in cement kilns is widely available and could be purchased to implement a co-firing of biomass along with fossil fuels. Taking Ethiopia as an example, the paper makes recommendations for formulating a strategy for integrated biomass technology to achieve not only economic benefits but also to deliver long-term energy security and sustainable development. Published data confirms that this investment is economically justifiable and environmentally beneficial.

11.2. INTRODUCTION

The purpose of this chapter is to evaluate the opportunities, barriers and costs associated with utilising biomass for thermal combustion in cement factories. It seeks to address the following questions:

- Is it possible to use biomass / biomass residues in cement plants?
- How is cement produced and where can biomass be used?
- What engineering modification or redesign of cement plants is required to burn solid biomass in cement kilns?
- What are the experiences of the global cement industry and available technologies?
- What preparation methods are needed to make biomass acceptable in an industrial application, such as size reduction and drying?
- What are the benefits?
 - Environment
 - Economical
 - Social
- What are the barriers for use of biomass in cement kilns?
 - Cost
 - Environmental, regulatory and legal issues
 - Technical, perception and skills
- What are the environmental and health and safety risks?
- Finally, recommendations are put forward, highlighting the potential benefits of using biomass in Ethiopia's cement factories.

Biomass refers to biological materials derived from living or recently dead biological materials, encompassing materials from both plants and animals. It includes plant tissues such as wood, charcoal and yarns; farm wastes such as coffee husks, teffe and chat; animal wastes, such as animal fat, dung, meats and bones; and household or industrial biological degradable wastes. These materials are primarily composed of carbon-based organic matter, which releases energy when it reacts or combusts with oxygen. When cultivated or sourced in a sustainable manner (such that the total stock of the resource does not diminish in size), biomass can be regarded as a form of renewable energy (Nicholls et al. 2008).

Although fossil fuels are also made from the remains of dead animals and plants, fossil fuels are not considered renewable on any scale of time that matters to humans (Shafiee and Topal 2009).

11.3. BIOMASS AS AN ENERGY SOURCE

Biomass is the oldest source of energy, used since mankind first harnessed fire and used wood as a source of heat, light, and power. For centuries before the invention of the steam and internal combustion engines, most of the world's energy came from biomass. The advent of industrialisation created the need for a large quantity, and more concentrated source, of energy. This led to large-scale exploration and utilisation of fossil fuels (Winandy *et al.* 2008). Nonetheless, biomass still accounts for 10% of global energy use, which is approximately five times more than the energy generated from hydroelectric power (IEA 2006). In the United States alone, about 11 gigawatts (GW) of electrical power is generated from bio-energy sources. This make biomass the second-largest US renewable energy source next to hydropower (94 GW), and more significant than wind energy (5 GW) and geothermal (2.7 GW) (Nicholls *et al.* 2008).

In the Less Developed Countries (LDCs), biomass accounts for almost one-third of all energy consumption. In fact, in sub-Saharan countries, biomass accounts for more than 80% of all energy needs, and is primarily used for cooking, lighting and heating (Palz and Kyramarios 2000). Figure 11-1 shows world energy demand by source.

Figure 11-1: 2007 world energy demand by source

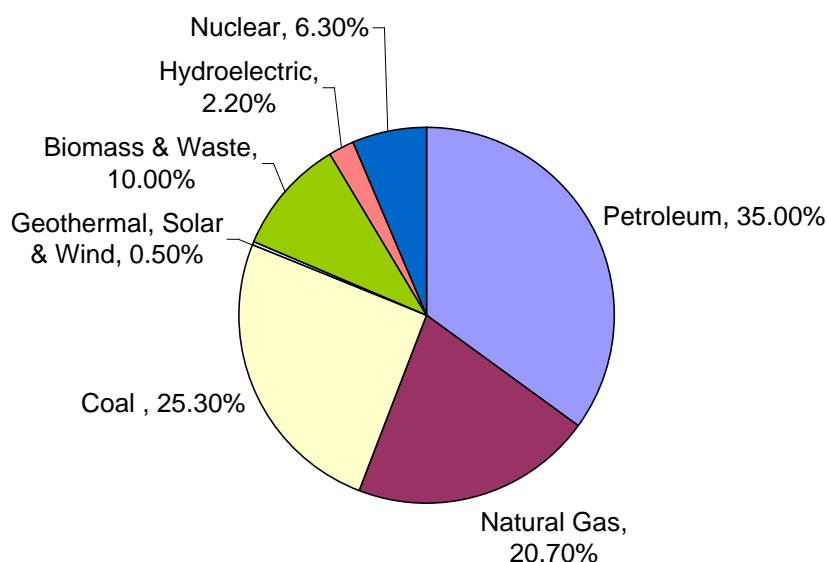

Source: IEA (2006)

With the growing realisation of the impact of fossil fuels on global warming, coupled with volatile energy prices and an emerging energy security agenda, there is a renewed interest in using biomass as a carbon-neutral and cost-effective alternative. For example, Nicholls *et al.* (2008) state that wood energy could potentially supply up to 10% of U.S energy demand. Currently it is below 4% and is expected to grow to 5% by 2020. As shown in Table 11-1, Wright (2006) put US biomass consumption at the lower level of 2.8% in 2005 and Brazil at 27.2%.

Biomass can be used as an energy source in a variety of ways: as a direct combustion feedstock in home stoves, thermal power plants, furnaces and boilers (possibly in combination with coal or other fossil fuels); or as a feedstock for pyrolysis, gasification, charcoal production, briquetting, transesterification or fermentation (the latter two for producing biodiesel and bio-ethanol).

Table 11-1: Percentage of biomass consumption

Country	Total (Exajoules)	Biomass (EJ)	Biomass %
Brazil	7.3	1.98	27.2
China	45.5	7.5	16.4
Canada	13.1	1.77	13.5
Sweden	2.2	0.34	15.9
Denmark	0.83	0.098	11.8
EU-25	70.5	2.75	3.9
U.S	103.4	2.92	2.8
UK	9.48	0.06	0.6

Source: Wright (2006)

11.4. CEMENT CHEMISTRY AND IMPACT ON THE ENVIRONMENT

Cement production is a large user of fossil fuels and producer of greenhouse gases (GHGs) (Worrell *et al.* 2001). In cement production, there are three sources of greenhouse gases.

1. The first source comes from the inherent nature of cement production. Cements are made from limestone, which predominantly contains more than 90 percent calcium carbonate (CaCO₃). As shown in chemical Equation 1, when heat is applied to CaCO₃ it dissociates into calcium oxide (CaO), which is the main ingredient for cement, and carbon dioxide (CO₂) which is a GHG.



For every 100 grams of calcium carbonate heated in a kiln above 750°C, about 44 grams of carbon dioxide and 56 grams of calcium oxide are produced. In effect, for every 56 grams of calcium oxide that is used by the construction industry, about 44 grams of carbon dioxide are released into the atmosphere. According to the European Cement Association (2009), approximately 525kg CO₂ per tonne of “clinker” is produced.³⁵ In 2007 alone about 2.77 billion tonnes of cement were produced globally, which means up to 1.45 billion tonnes of CO₂ were released from de-carbonisation of CaCO₃ alone into the atmosphere.

Table 11-2: 2007 world cement production by region

Cement Production	Percentage (%)
Asia	70.1
China	48.7%
Japan	2.4%
India	6.1%
Other Asia	12.9
USA	3.4
Other America	6.2
European Union 27	9.7
Africa	4.4
Oceania	0.4
CIS	2.4

Source: European Cement Association (2009)

2. The second source of greenhouse gases comes from the combustion of carbon-containing fossil fuels such as methane, furnace fuel, coal or alternative fuels such as biomass, re-ground tyres, and household and industrial wastes.

The mechanism by which carbon-containing fuel burns to give off carbon dioxide is given in Equation 2 using the smallest hydrocarbon compound, methane (CH₄).

³⁵ Clinker is a solid intermediary cement product that is formed at high temperature through total or partial fusion of cement raw materials.



The European Cement Association (2009) estimates that overall carbon dioxide production from combustion of fuel in the kiln is approximately 335 kg of CO₂ per tonne of cement.

3. **The third source** of carbon dioxide derives from the use of electricity produced by power stations that are burning fossil fuels. This accounts for approximately 50 kg of CO₂ per tonne of cement produced (European Cement Association 2009). Countries, such as Ethiopia, that generate a significant fraction of their electricity from hydroelectric power stations do not produce large quantities of carbon dioxide from the use of electrical motors. However, cement plants in these countries do, of course, produce carbon dioxide from the first two sources.

When all the carbon dioxide produced from the three sources is added together, the cement industry releases about 0.8 tonne of carbon dioxide into the atmosphere per tonne of cement produced. This makes cement production one of the largest sources of greenhouse gases, producing 5% of global emissions (Worrell *et al.* 2001). This is more than the emissions from the global steel industry. According to the Intergovernmental Panel on Climate Change (IPCC), the steel industry accounts for between 3 to 4% of total world greenhouse gas emissions (World Steel Association, 2007).

Carbon dioxide (CO₂) from decarbonisation of limestone can be reduced by diluting cement clinker with raw, thermally untreated rocks such as pumice, gypsum, pozzolan, or ground furnace slag. For example, pumice rock can be added up to 15% with some compromise on physical properties, strength or setting time of cement for less critical constructions (Hossain 2003). Hence, carbon dioxide from decarbonisation of limestone can be reduced—but cannot be fully eliminated—as long as cement is made from CaCO₃. There is ongoing research into the development of “eco-cement” made from magnesium oxide (MgO) which can absorb carbon dioxide and water to set and harden (Harrison 2009). But the chemistry of cement *per se* (as opposed to the energy sources used to make the cement) is beyond the scope of this paper and will not be considered further.

However, CO₂ from the burning of fossil fuels can be reduced and, even more importantly, can be made carbon-neutral with the utilisation of biomass as an energy source for pyroprocessing. To understand how this can be achieved, it is important to understand how cement is produced and the types and amounts of energy needed to make cement.

11.4.1. CEMENT PRODUCTION PROCESS

Cement manufacturing starts with the quarrying of more than one raw material to provide a source of necessary metallic oxides, such as calcium oxide from limestone, iron and aluminium oxides from clay and silicon oxide from sand. Big rocks blasted from quarries are crushed into gravel to facilitate transportation, blending and milling into powder.

There are two processes of raw material grinding and blending. Those are known as the “wet” process and the “dry” process. In the wet process, the materials are ground and homogenised as slurry. This method was traditionally preferred to achieve homogeneity of feedstock, but following improvements in dry mixing and blending of powder materials most modern cement factors now use the dry process because it requires less energy per tonne of clinker.

Using the dry or wet process, different types of cement are made for various applications. The most common cement used in civil construction today is Ordinary Portland Cement (OPC), but there are specialist cements such as rapid heat cement, high alumina cement, oil-well cement, quick set cement, etc. For example, the raw material for Portland Cement needs to be predominantly calcareous, rich in calcium oxide (CaO) and with smaller amounts of siliceous (SiO₂), aluminous

(Al₂O₃) and iron-rich (Fe₂O₃) content. Most often, between 70-99% of this calcareous component comes from limestone deposits. Clay, sand or other minerals are also milled with limestone in the correct proportions to achieve the following proportion in the cement clinker (Chatterjee 1983):

- CaO 63-67 %
- Al₂O₃ 4- 7%
- Fe₂O₃ 2-4 %
- SiO₂ 21-24%
- Trace amounts 2-3%

Once the correct proportions of these chemical compounds are achieved, the material is fed into pre-heating cyclones to be heated to decompose some of the CaCO₃ and prepare it for further reactions that will take place. In the kiln, as shown in

Figure 11-2, the temperature of the material reaches around 1,450°C and the air temperature is as high as 2,000°C. During this process of chemical reactions, a black/grey solid mass is formed through partial or total fusion of the raw materials. This is known as clinker (Peter 2001).

Figure 11-2: Temperature profile of pre-heating cyclones and kiln

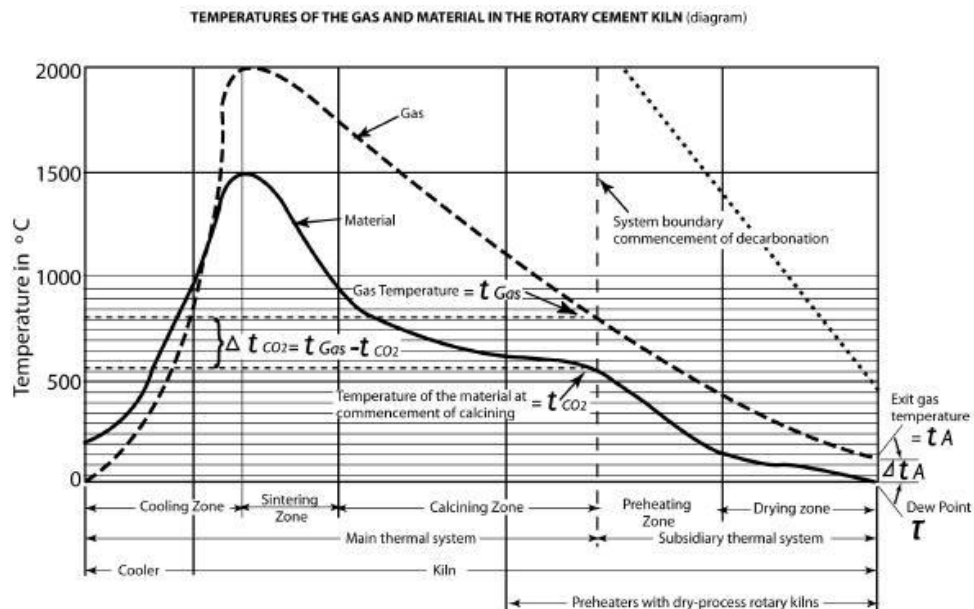

Source: Hansen (1990)

11.5. CHEMICAL REACTION OF CLINKER PRODUCTION

The pre-heated material in the cyclones is dropped into the kiln for complete reaction. Most modern cement kilns are rotary shafts with a diameter ranging from 3.5m to 5.5m and a length of between 50 to 200m. Coal, gas, fossil fuels or alternative fuels are continuously injected into the kiln to burn and produce heat of about 1,450°C in the clinker production zone.

A typical Portland cement clinker consists of at least two-thirds mass of calcium silicates (CaO)₃SiO₂ and (CaO)₂SiO₂ and the remainder consists of aluminium oxide (Al₂O₃), iron oxide (Fe₂O₃) and other oxides (Peter 2001). Once the clinker is formed it drops into a cooler where air is blown in at one end to remove the heat from the partly-softened and molten material and turn it into small pebbles. The

clinker is then ground in a cement mill—with or without “extender minerals” such as pumice, gypsum, pozzolan or ground furnace slag—to produce cement.

To carry out these operations a large amount of electrical and fossil fuel energy is used, which is discussed in the next section.

11.5.1. ENERGY CONSUMPTION OF THE CEMENT INDUSTRY

Cement production is one of the largest users of fossil fuels. According to energy consumption benchmarking carried out in Canada, the energy cost of cement production is between 25-35% of the total direct cost of cement production. A similar analysis carried out in Poland estimated energy costs to be between 30-40% of the total costs of cement production (Mokrzycki *et al.* 2003). Messebo Cement factory in Ethiopia reports that it spends up to 60% of its total cost of production on imported furnace fuel, which is exceptionally high compared with the industry standard (Addis Fortune, 2007). This figure is probably distorted by cheap labour and other costs. Nonetheless, this high proportion of energy cost has been a major driver for the industry to search for cost-effective and alternative fuels.

Fuel consumption at a cement plant depends on the type of process the plant uses. As shown in Table 11-3, total energy consumption used during the wet cement production process is much higher than in the dry kiln process.

Table 11-3: Typical fuel consumption of three kiln types

Kiln Type	Average Fuel Consumption GJ/tonne clinker
Wet Kilns	6.0
Dry Kilns – Single stage pre-heater	4.5
Dry Kilns – Multi-stage pre-heater	3.6

Source: Energy Innovation Initiative in Canada (2001)

Ruth *et al.* (2000) estimate that the most efficient and modern kilns could use as little as 3,200 MJ of energy per tonne of clinker produced. Assessing the Polish cement industry, Mokrzycki (2003) derived average energy consumption of Polish factories at around 4,100 MJ per tonne of clinker. On average, Mokrzycki (2003) states that the energy required for the production of one tonne of cement is about 120 kg of coal. Another study carried out in Pakistan suggests that about 85 kg of furnace oil is used to produce a tonne of cement (Kazmi 1996). Ethiopia’s cement factories use imported furnace fuel, probably with similar energy efficiency to that of Pakistan.

The scope of this report is to assess the use of fuel directly injected into the rotary kiln to generate flame and heat of around 1,450°C. This heat activates the decomposition of calcium carbonate and facilitates solid state reactions between aluminium, iron, silicon and calcium oxides to produce a new chemical structure substance called clinker. To achieve these reactions, three types of fuels are commonly used.

11.5.2. TYPES OF FUELS USED IN CEMENT KILNS

In the context of the cement industry, there are three sources of fuels used in kilns. These are fossil fuels, biomass, and non-renewable wastes.

Fossil Fuels: Fossil fuels represent the main sources of energy used in cement production. Principal fossil fuels used are coal, petroleum coke and petroleum-based fuels such as natural gas and heavy furnace fuel.

Biomass: These materials are, in principle, “renewable” because they can be re-grown at a rate equal to, or greater than, the rate of harvesting; they are “carbon-neutral” because plants absorb carbon dioxide as they grow. Biomass waste such as forest products, fuelwood, foliage, shavings, agricultural crops, cotton stokes, rice straw, sugarcane, flower farm waste and wheat straw are widely used as renewable and carbon-neutral fuels. Industrial-scale animal wastes, such as bones, fats, meats and other animal wastes, also fall under the biomass category.

Non-renewable wastes: These materials are wastes or materials at the end of their service lives. They can be burnt in the cement kiln to recover energy and conserve fossil fuels that would have otherwise been used. Some, such as plastics and rubber wastes, can also cause environmental hazards when dumped in landfills. Rubber tyres, plastics, hydraulic oil, grease and hydrocarbon-based household or industrial wastes can be used as an energy source in cement factory kilns.

The European Cement Association (1998) states that “[w]aste is used in cement manufacturing as an alternative fuel and raw material, thereby providing a significant contribution to waste management. Unlike incinerators, the cement manufacturing process “absorbs” all of the elements present in the burnt waste. In this way, it cuts both its production costs and global GHG emissions. Today, on average, alternative fuels provide about 17% (up to 72% in some regions) of thermal energy consumption in European cement plants” (European Cement Association, 1998).

Though there are no clear specifications for determining what would be a good waste fuel, Lafarge Cement has developed the following specifications to protect the environment and conserve the efficiency of their cement kilns (Mokrzycki *et al.* 2003):

- Calorific value – over 14.0 MJ/kg (weekly average)
- Chlorine content – less than 0.2%
- Sulphur content – less than 2.5%
- Polychlorinated Biphenyls (PCB) content – less than 50ppm
- Heavy-metal content – less than 2,500 ppm, out of which:
 - Mercury (Hg) – less than 10ppm, and
 - Total cadmium (Cd) and thallium (Tl) less than 100ppm

Most hydrocarbon-based materials are safe to burn in the kiln to provide energy as long as they meet the above guidelines. Results in Table 11-4 give a rough range of calorific values for different cement fuels materials.

Table 11-4: Calorific values of different fuels

	Low Heat Value (LHV)	High Heat Value (HHV)
	MJ/kg	MJ/kg
Coal	27.8	29
Coal Fines	20.4	21.5
Petroleum Coke	29.7	32.8
Liquid Hazardous Waste-Derived Fuel	22.6	25.8
Waste Tyre	31.5	33.0
Wood	19.7	20.7
Hog Fuel Sawdust	19.7	21.2
Municipal Waste	13.2	15.1

Source: Hansen (1990)

As a result of these calorific value differences, the fuels cannot be replaced by each other at a one-to-one ratio. An adjustment has to be made to compensate for the loss of calorific value. For example, an approximate 1:1.4 coal-to-wood ratio is needed to replace coal with wood to achieve similar heat energy in the kiln.

Though the scope of this paper is principally interested in the use of biomass, it discusses non-renewable waste materials as a source of fuels in the cement industry for two reasons.

First, finding a sustainable supply of biomass with uniform calorific value could be challenging from a supply as well as a logistical perspective. This may discourage cement factories from investing in modifications of their systems to burn biomass fuels only.

Second, the cost of biomass could be higher and there may not be clear cost benefits. Alternative waste fuels are often free, except the cost of collection, transportation and processing of these materials. In some cases, waste may even be “negative cost”, where waste producers pay cement factories to take away their wastes.

11.5.3. REAL-LIFE EXAMPLES OF BIOMASS USE IN CEMENT KILNS

Burning biomass in cement kilns is occurring more often due to volatile energy prices and environmental benefits. The following are a few examples reported in various publications.

- **Kenya:** A cement firm operating in Kenya and Uganda claims to have cut its “annual carbon dioxide emission by reducing its use of fossil fuels in cement making by 20 %. The company, which is partly owned by Lafarge Cement, plans to reduce its use of coal by using wood from its own plantations as well as coffee, rice and cashew nut husks. It is targeting a reduction of 132,000 tonnes of CO₂ per annum by 2010.” (Reuters 2008; Lafarge 2007).
- **Uganda:** Uganda’s Hima cement factory burns coffee husks as a CDM project. This project is expected to save the factory about \$3.1 million in foreign exchange per annum (Cement World 2008).
- **Malaysia:** Investigations performed to evaluate the feasibility of using biomass fuels as a substitute for fossil fuels in Malaysia’s cement industry have reached the following conclusions (Evald and Majidi 2004):
 - The economic feasibility of using biomass in the cement industry is very good, with a 263% financial internal rate of return (FIRR)
 - The cement sector is an obvious choice for the use of solid biomass because of the ease of replacement of coal.
 - For the cement industry, the combination of a very large volume of fuel substitution involving a relatively small investment cost allows for significant savings from the use of alternative fuels.
- **Germany:** Heidelberg Cement claims to have increased the use of alternative fuels up to 78% in one of its plants and 66% in another. It uses tyres, plastics, paper residues, animal meal, grease and sewage sludge to replace fossil fuels. It states that the company had to invest €8 million in one plant and another €4 million on storage equipment, homogenization and dosing installations for flexible use of alternative fuels (Hridelberg Cement 2009).
- **Indonesia:** Heidelberg Cement’s Indonesian subsidiary was approved as the first CDM project in Indonesia in 2005. The company claims to have increased the use of alternative

fuels, in particular rice husks and residues from palm oil production, replacing coal (Hridelberg Cement 2009b).

- **Poland:** Six cement plants in Poland currently use alternative fuels. Lafarge Poland Ltd. has been using combustible fractions of municipal wastes, liquid crude-oil derived wastes, car tyres, waste products derived from paint and varnish production, expired medicines from the pharmaceutical industry, bone meal provided from meat processing plants, coke from the chemical industry and emulsified oil from a refinery (Mokrzychi *et al.* 2003).
- **India:** Cement companies in India are using non-fossil fuels including agricultural wastes, sewage, domestic refuse and used tyres, as well as a wide range of waste solvents and other organic liquids (Bernstein *et al.* 2007). The Indian Cement firm ACC is using cow dung, old shampoo, soap, plant sludge and municipal waste as alternatives to fossil fuels (Cement World 2008).
- **USA:** In the United States, approximately 5% of fuel used in the cement industry comes from renewable and non-renewable waste fuels such as wood, tyres and other non-hazardous and hazardous materials. Various sources suggest the availability of millions of tonnes of wood that could be used in cement factories to reduce GHG emissions and minimise forest fires (Mackes and Lightburn 2003).
- **UK:** Cemex cement factory in Rugby uses alternative fuels such as tyres and “climafuel”, which is derived from household and commercial wastes. The “climafuel” can contain at least 50 % biomass, displacing nearly 180,000 tonnes of fossil fuel CO₂ (Cemex 2009; Cement News 2009). The Lafarge plant at Hope uses bone meal which is expected to reduce 30,000 tonnes of CO₂ emissions per year (Cement World, 2008).
- **Austria:** Austria’s cement factories were amongst the earliest to start burning tyres (since the 1980s), and have been burning solid waste such as plastics, paper, textile and composite materials since 1993. All nine cement plants in Austria use solid waste to various degrees (European Cement Association 2009). One of the factories, Wietersdorfer & Peggauer cement plant, claims to have used alternative fuels substituting up to 70% of fossil fuels (Zieri 2007).
- **Tunisia:** A feasibility study carried out to study the use of municipal solid waste (MSW) as a replacement for natural gas in the cement industry was found to be unattractive economically due to the high cost involved in collection and sorting of the MSW and government subsidies on natural gas imports (Lechtenberg 2008).
- **Canada:** St. Mary Cement in Ontario, Canada, wants to replace 13 % of its fuel consumption with wastes such as paper sludge left over from recycling and plastic films. A factory in British Columbia uses renewable synthesis gas products from its gasifier, enabling it to replace 6% of its fossil fuel consumption (Dufton 2001).
- **Portugal:** Cement producer Cimpor Cimentos de Portugal is using hazardous hydrocarbon waste in its plant in Souselas, Central Portugal (Cement World 2008).

The list of cement factories using biomass and waste fuels is longer, but the above diverse examples are sufficient to strengthen the argument that:

- Biomass and alternative fuels can be used in the cement industry.

- Biomass, as well as non-renewable waste fuels, can be an economical alternative to fossil fuels.
- There is well-established materials preparation, feeding and burning technology that can be purchased by cement factories to adopt a co-firing technology.
- It is clear that using biomass in the cement industry is possible and achievable. In the following section some of the benefits are discussed.

11.6. BENEFITS OF USING BIOMASS AND ALTERNATIVE FUELS

11.6.1. ENVIRONMENTAL BENEFITS

Biomass is a renewable energy resource that can be replaced by growing trees, crops or other vegetation to maintain the level of sequestered carbon in the environment. In addition to capturing carbon dioxide, planting vegetation protects land fertility, prevents solid erosion, reduces sedimentation at dams and water reservoirs, provides ecosystems for wildlife and insects and, of course, produces wood for high-value timber use as well as biomass.

Plants absorb carbon dioxide during photosynthesis. As shown in the following chemical equation, this cycle continues as long as trees are planted to absorb carbon dioxide, to “cancel out” the carbon dioxide released from combustion of the cultivated biomass. That is why sustainable biomass is considered to be carbon-neutral, with no net increase of carbon dioxide into the atmosphere.

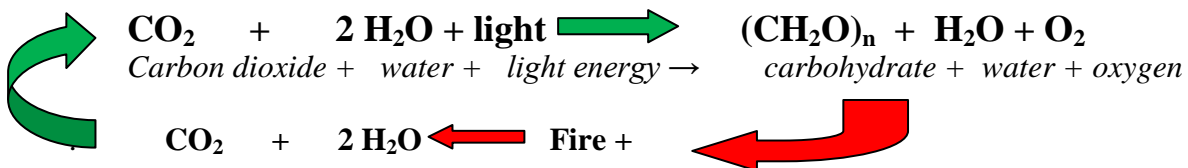

The use of waste as alternative fuels in the cement industry has numerous environmental benefits, such as:

- Alternative fuels reduce the use of fossil fuels.
- Contributes towards lowering emissions of greenhouse gases from materials that would otherwise have to be incinerated (with corresponding emissions) or left in the landfill to decompose (and generate methane).
- Maximises the recovery of energy from waste. All the energy is used directly in the kiln for clinker production.
- Maximises the recovery of the non-combustible part of the waste and eliminates the need for disposal of slag or ash, as the inorganic part is incorporated into the cement.
- Improves waste management and public health. High temperatures in the kilns, long residence times and the ability to absorb inorganic residue/ash allow the complete destruction of combustible hazardous waste while recovering the energy they contain in an environmentally sound manner (Hansen 1990; Van Loo 2006). For these reasons, the cement industry is recognised by some European governments as an essential part of their waste management policy (European Cement Association 1998).
- The only viable means of safe, permanent disposal of this combustible waste is by thermal treatment. Cement kilns are not only ideally suited for the safe disposal of this material, but they also can recover the energy to reduce use of fossil fuel.

11.6.2. ECONOMIC BENEFITS OF USING BIOMASS AND ALTERNATIVE WASTE FUELS

- Between 30-40% of the total cost of cement production is accounted for by energy needs. This means a significant reduction in cost can be achieved by using renewable and waste fuels. For example, the study carried out in Malaysia estimates that a 263 % FIRR can be achieved (Evald and Majidi 2004). Hence, burning biomass and waste as a source of energy could save significant costs.
- Burning biomass and waste can save foreign currency by replacing imported fuels.
- Provides energy security for land-locked countries such as Ethiopia and hedges against volatile global energy markets.

11.7. TECHNOLOGY

Biomass burning in cement kilns is a well-established technology, which can be purchased or custom-made in developing countries. Existing feeding systems of alternative fuels into kilns are robust and it is possible to feed in biomass ranging from small pellets to full-sized tyres. For ease of handling and achieving uniform calorific input into the kiln, it is important to reduce biomass materials to manageable sizes. For example, solid woody biomass needs to be chipped into small sizes, pre-dried, and unwanted materials such as stone and metal bits removed (Nicholls *et al.* 2008).

Figure 11-3: Rubber tyre feeding system through bottom of pre-calcination region

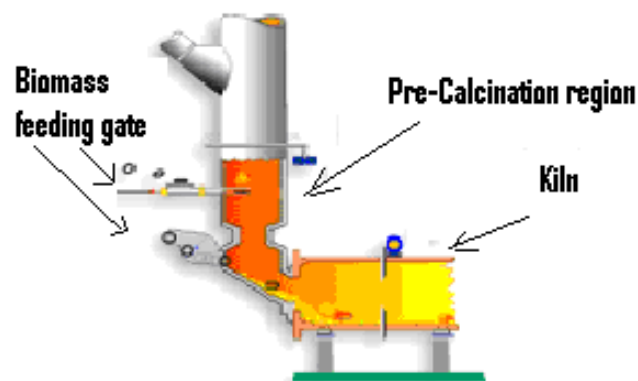

Source: Derksen (2009)

Alternative and biomass materials can be fed in three principal ways:

- 1) As shown in Figure 11-4, large-size biomass and alternative waste fuels such as tyres can be fed into the kiln in specially-made gates at the bottom of the pre-calcining region.
- 2) It is possible to grind wood along with cement raw materials to feed as pulverised fuel. However, this process may cause two potential problems (Mackes and Lightburn 2003):
 - Due to the low ignition temperature of wood, fire may start during the milling process unless special precautions are put in place.
 - It may also affect the efficiency of the mill if the moisture content of the wood is high. Though it may make it easier to feed into the kiln, grinding the biomass adds to costs.

- 3) Companies that use coal as a main source of energy can blend biomass or alternative materials with coal to feed it into the kiln using a coal-feeding system.

Of the three methods described, feeding through specially-made gates at the pre-calcination region is the safest choice. There are already rotary valves or screw feeders on the market that can be easily installed. The screw feeder has certain advantages over the rotary valve as coarse materials can easily be pushed into the pre-calcining region and the feed rate of the biomass can be regulated by the speed of the screw.

Conveyer belts are used to transport biomass materials from storage to feeding hoppers. From the hoppers, a screw conveyor feeds the biomass into the pre-calcination region.

11.7.1. POTENTIAL BARRIERS

Burning alternative fuels is beneficial to cement companies as well as the environment. But there are barriers to successful utilisation of biomass in the cement industry:

- **Supply:** obtaining a constant and sufficient amount of biomass.
- **Consistency:** the variability in calorific value of biomass may affect the efficiency and output of kiln production.
- **Harvesting:** although extensive biomass resources are available in many countries, often such biomass is spatially dispersed and difficult to aggregate together.
- **Cost:** the capital costs for the preparation and densification of biomass at harvesting sites, as well as modifications of the cement factory, may not justify biomass use.
- **Accessibility:** infrastructure barriers, roads, and transportation.
- **Skill barriers:** Mulugeta (2008) states that despite wood-based fuels being used by more than 90 % of the population in Ethiopia, there are no biomass research centres in the country that study sustainable biomass development, help to upgrade skills, or that can replenish stocks.
- **Scepticism:** Management and decision-makers may regard burning household waste in modern factories with some degree of scepticism. Hence, champions are needed to overcome this resistance to change.
- **Unwanted materials:** Biomass often contains unwanted materials, such as metal wastes that may damage machines and that need to be removed using metal detectors. The European Cement Association (2009) also classify nuclear waste, infectious medical waste, entire batteries, and untreated mixed municipality waste as unsuitable for the cement industry and public health.

11.7.2. ADVERSE EFFECTS ON THE ENVIRONMENT

- **Deforestation:** Industrial-scale usage of biomass may add to already-present stresses on biomass resources, thereby inadvertently encouraging deforestation (Mangoyana, 2009).
- **Hazardous substance release:** In many developing countries, there may not be stringent regulations, or enforcement of regulations, regarding air quality. This may invite companies to take a less responsible approach to burning chlorine-containing wastes such as PVC pipes and PVC packaging that may lead to formation of toxic dioxins (polychlorinated dibenzo-p-dioxins and polychlorinated dibenzofurans) or industrial wastes containing toxic metals such as mercury, cadmium or chromium (Court, 2005; WHO, 2007).
- **Health:** In the absence of proper treatment, transportation of household and industrial waste could spread germs and disease.

11.8. ECONOMIC AND ENVIRONMENTAL JUSTIFICATION FOR USING BIOMASS IN ETHIOPIA

A total of 24 companies have permits to invest in cement production in Ethiopia, out of which 13 have begun installation and construction work (All African News 2008). By 2011, the total amount of cement production in Ethiopia is estimated to be 17 million tonnes per annum (Taye 2008). This is going to increase the competition and price pressure on cement factories, squeezing their profit margins. This volume will enable the country to jump from its current position of 78th in the world ranking of cement producers to one of the top 30, placing it above the UK, Canada and Australia.

This will exert considerable pressure on energy supply in the country. The country will probably have 24 cement factories within a short time, increasing cement production from the current level of approximately 1.6 million tonnes to 17 million tonnes. That means the country will have to import approximately 1.4 million tonnes of furnace fuel. At the current market price of US\$400 per tonne, the country may need to spend billions of dollars on furnace fuel alone. This is simply unaffordable in the context of a total national export value of US\$1.5 billion dollars per year.

11.8.1. STRATEGIES AND BENEFITS IN ETHIOPIA

- **Farm Wastes:** Coffee waste, cotton, oil processing, chat, sugarcane, flower farms and processing plants can be used as seasonal sources of biomass.
- **Commercial Plantations:** Cement factories can start commercial plantations of trees on their own lands. The factories' land could be used to plant trees at the commercial level to harvest for cement production. According to Ethiopian investment law, land for tree plantation is free and no lease fee is paid on it.
- **High-value products:** In addition to biomass fuel, high-value timber can be sold to maximise the return on investment.
- **Public Health:** The capital city, Addis Ababa, has no proper waste management system. Household as well as industrial waste is dumped on open land, causing environmental problems and health risks. Heavy pollution of Koka Lake is a result of waste influx from tanneries, flower farms, industrial facilities and household waste (Aljazeera, 2009). Having the capability to burn alternative waste could encourage municipalities to invest in waste-processing plants and industries to collect and supply hydrocarbon-based wastes to the cement industry. This would contribute to public health, reduce methane emissions and save energy costs.
- **Hazard management:** Liquid hazardous wastes that are often generated from industrial hydraulics and automotive lubricant can be blended with furnace oil to be burnt in the kiln, preventing the pollution of drinking water and poisoning of aquatic life (Hansen 1990).
- **Financial incentives:** As international concern over global warming and GHG arise, government and international organisations may provide financial support for the utilisation of biomass, reducing the burden on the industry. Biomass-switching in the cement industry also has a rich pedigree in the Clean Development Mechanism (CDM).

11.9. CONCLUSIONS

The use of biomass and waste fuels is a growing area based on sound economic and environmental benefits. Biomass fuel-switching is possible, achievable and beneficial to the environment and companies that are willing to embrace it. Once implemented, companies can also benefit from the generation of carbon credits through the Clean Development Mechanism (CDM). Countries such as

Ethiopia could save foreign currency, create jobs and start a sustainable biomass industry. This would help to reduce deforestation and soil erosion, while simultaneously offering social benefits to rural communities.

11.10. REFERENCES

- All Africa News, August 28, 2008, Ethiopia: Cement Plant Imports 22,000 Ton Clinker from Pakistan. Website (accessed 20 February 2009): <http://allafrica.com/stories/200808260091.html>
- Aljeezera, Feb 21, 2009, People and Power, a three part report under title of Green Lake. Website (accessed 25 February 2009): <http://www.youtube.com/watch?v=eUqgUR4q198>
- Bernstein, L.; Roy, J. Delhotal K.C, Harnisch J, Matsuhashi R, Price L, Tanaka K, Worrell E, Yamba F, Fengqi Z, (2007), Industry. In *Climate Change 2007: Mitigation*. Cambridge University Press, Website (accessed March, 2009 <http://www.ipcc.ch/pdf/assessment-report/ar4/wg3/ar4-wg3-chapter7.pdf>)
- Cement World (2008) Kenyan cement firm aims to increase its use of alternative fuels. *Cement World*.
- Cement World (2008) Cimpor makes uses of hazard waste. *Cement World*.
- Cemex Cement (2009) Climafuel in the United Kingdom. Website (accessed 13 March 2009): http://www.cemex.com/su/cs/su_ca_en_cc_cl.asp
- Chatterjee, A.K. (1983) Chemico-Mineralogical Characteristics of Raw Materials, in *Advanced Cement Technology*. Ghosh, S.N. (ed.). Oxford: Pergamon Press.
- Court, J. (2005) Alternative fuels at Berrima cement works – Blue Circle Southern Cement. Denistone, Australia: J D Court and Associates Pty Ltd. Website (accessed 17 March 2009): http://www.planning.nsw.gov.au/assessingdev/pdf/bcsc_berrima_report_final.pdf
- Derksen, K., 2009. Cadence recycling brochure. Website (accessed 17 March 2009): <http://www.cadencerecycling.com/pages/PapersBrochures.html>
- Dufton, P. (2001) *End-Of-Life Tyres - Exploiting Their Value*. Rapra Industry Analysis Report Series.
- Energy Innovation Initiative in Canada (2001) Energy consumption benchmark guide: cement clinker production. Ottawa: Natural Resources Canada. Website (accessed 13 March 2009): http://oee.nrcan.gc.ca/publications/industrial/BenchmCement_e.pdf
- Evald, A. and Majidi, M. (2004) Biomass Fuels for Industrial Use. Denmark & Kuala Lumpur: Malaysian-Danish Environmental Cooperations Program Website (accessed 20 February 2009): <http://eib.ptm.org.my/upload/files/Report%2010%20Biomass%20fuels%20for%20industrial%20use.doc>
- European Cement Association (1997a). Alternative fuels in cement manufacture: technical and environmental review. Brussels: Cembureau. Website (accessed 20 February 20, 2009): http://www.cembureau.be/Documents/Publications/Alternative_Fuels_in_Cement_Manufacture_CEMBUREAU_Brochure_EN.pdf
- European Cement Association (1998) Climate change: cement and the EU. Website (accessed 21 February 2009): <http://www.cembureau.be/>
- Global Alternative Fuels News. (3 April 2008) Kenyan cement firm aims to increase its use of alternative fuels. Global Alternative Fuels, (accessed 17 March 2009): <http://www.propubs.com/GF>
- Global Alternative Fuels News. (14 April, 2008) Cimpor makes uses of hazard waste. Global Alternative Fuels. (accessed 17 March 2009): <http://www.propubs.com/GF/>
- Hansen, E R. (1990) New Ways to burn hazardous waste. Website (accessed 18 February 2009): <http://www.cadencerecycling.com/pdf/papers2.html>
- Harrison, J. (2009) Eco-Cement. Glenorchy: TecEco Pty Ltd. Website (accessed 22 February 2009): <http://www.tececo.com/simple.eco-cement.php>
- Hridelberg Cement. (2009) Germany - ahead in using alternative fuels. Website (accessed 22 February 2009): www.heidelbergcement.com/global/en/company/sustainability/case_studies/alternative_fuels.htm
- Hridelberg Cement. (2009b) First CDM project in Indonesia. Website (accessed 22 February 2009): http://www.heidelbergcement.com/global/en/company/sustainability/case_studies/CDM_project_Inonesia.htm
- Hogan, E. (1994) Overview of Canadian Thermochemical Biomass Conversion Activities, in *Advances in Thermochemical Biomass Conversion, Volume 1*. Bridgewater, A.V. (eds.), Blackie Academic.

- Hossain, K.M.A. (2004) Properties of volcanic pumice based cement and lightweight concrete. *Cement and Concret Research*: 34: 283-291.
- IEA (International Energy Agency). (2006) *Key World Energy Statistics 2006*. Paris: IEA.
- Kazmi, S.H. (1996) The troubled cement industry. *Pakistan Economist*. Website (accessed 21 February 2009): <http://www.pakistaneconomist.com/database2/cover/c96-97.asp>
- Lafarge (2007) Lafarge in Kenya and Uganda: a sustainable commitment. Paris: Lafarge.
- Lechtenberg, D. (April 2008) Tunisia – waste management and the cement industry. *Global Cement Magazine*, pp. 10-11
- Mackes, K., and Lightburn, C. (2003) Evaluating the use of green wood chips processed from small-diameter trees as an alternate fuel for making cement. *Forest Products Journal* 53(4)
- Mokrzycki, E., Uliasz-Bochenczyk, A., Sarna, M. (2003) Use of alternative fuels in the Polish cement industry. *Applied Energy* 74: 101-111.
- Mangoyana, B, R. (2009) Bio-energy for sustainable development: An African context. *Physics and Chemistry of the Earth*, vol.34, pp 59-64.
- Mulugeta, Y. (2008) Human capacity and institutional development towards a sustainable energy future in Ethiopia. *Renewable and Sustainable Energy Review* 12: 1435-1450.
- Nicholls, D., Monerud, R., and Dykstra, D. (2008) A synthesis of Biomass Utilization for Bio-energy Production in the Western United States, General Technical Report PNW-GTR-753. Washington, DC: United States Department of Agriculture Forest Service.
- Palz, W., Kyramarios, A. (2000) *Bio-energy Perspectives in Developing Countries*. First World Conference on Biomass for Energy and Industry, 5-9 June 2000, Sevilla, Spain,.
- Peter, C.H. (ed.) (2001) Portland Cement: Classification and Manufacture. *Lea's Chemistry of Cement and Concrete*, 4th ed. Oxford: Elsevier Butterworth-Heinemann
- Reuters. (2008) Kenya cement firm details planned CO₂ emissions cut. Website (accessed: March 10, 2009): <http://www.reuters.com/article/rbssIndustryMaterialsUtilitiesNews/idUSL1161019120080311>
- Ruth, M., Worrell, E., and Price, L. (2000) *Evaluating Clean Development Mechanism Projects in the Cement Industry Using a Process-Step Benchmarking Approach*. Washington, DC: US-EPA.
- Shafiee, S. and Topal, E. (2009) When will fossil fuel reserves be diminished? *Energy Policy* 37: 181–189.
- Skidmore, J. (2008) Old tyres on the move - Handling solutions for wastes that turn into fuel. Website (accessed 26 February 2009): www.waste-management-world.com/.../Old-tyres-on-the-move---Handling-solutions-for-wastes-that-turn-into-fuel
- Taye, D. (2008) Production of new cement factories may exceed demand. *The Ethiopian Reporter*. Website (accessed 25 February 2009): <http://en.ethiopianreporter.com/content/view/18/26/>
- Van Loo, W. (2008) Dioxin/furan formation and release in the cement industry. *Environmental Toxicology and Pharmacology* 25: 128–130.
- Winandy, J.E., Williams R.S, Rudie A.W, Ross R.J, (2008) *Opportunities for Using Wood and Biofibers for Energy, Chemical Feedstocks, and Structural Applications*. Washington DC: US Forest Service.
- Wikipedia. (2009a) Greenhouse gases. Website (accessed 22 February 2009): http://en.wikipedia.org/wiki/Greenhouse_gas
- Wikipedia. (2009b) List of countries by cement production. Website (accessed 25 February 2009): http://en.wikipedia.org/wiki/List_of_countries_by_cement_production
- Worrell, E., Price, L., Martin, N., Hendriks, C., and Meida, L. O. (2001) Carbon dioxide emissions from the global cement industry. *Annual Review of Energy and the Environment* 26:303-329.
- World Steel Association (2007) A global sector approach to CO₂ emissions reduction for the steel industry – a position paper issued by the World Steel Association, December 2007. Website (accessed 14 March 2009): www.worldsteel.org/pictures/storyfiles/Global%20sector%20approach%20position%20paper.pdf
- Wright, L., 2006, Worldwide commercial development of bio-energy with a focus on energy crop-based projects, *Biomass and Bio-energy*, vol 30, pp. 706-714
- WHO (World Health Organization) (2007) Dioxins and their effects on human health, *WHO Fact Sheet No. 225*. Geneva: WHO. Website (accessed 27 March 2009): www.who.int/mediacentre/factsheets/fs225/en/
- Zieri, W. (2007) *Modernisation of the Wieterdorfer & Peggaver Cment Plant*. 7th European Conference and exhibitions, Vienna, 19-20 March 2007.

12. BIOMASS GASIFICATION AND PYROLYSIS: OPPORTUNITIES AND BARRIERS FOR EFFICIENCY AND SUSTAINABILITY

By Simon Dalili

Consultant

Contact: simon.dalili@gmail.com

12.1. ABSTRACT

This chapter provides an overview of pyrolysis and gasification and evaluates the opportunities and barriers associated with improving their efficiency and socio-environmental sustainability. Pyrolysis and gasification are thermo-chemical conversion technologies that decompose biomass and its residues into valuable intermediate products. Slow pyrolysis for charcoal production is a well-known commercial technology, while fast pyrolysis also occurs in the absence of oxygen but at higher temperatures and over a significantly shorter time. Gasification is the process of partial oxidation of a solid or liquid carbonaceous material by heating at temperatures above 800°C, in the presence of an oxidizing agent, during which the feedstock breaks down to produce raw gas. Raw gas can then be combusted immediately to produce heat and electricity or further transformed into liquid fuels. The bio-refinery concept—i.e. parallel production of several commodities such as electrical power, biofuels and chemicals from the same feedstock—is essential to the promotion of pyrolysis and gasification. The chapter closes with discussion of suitable policy and financial instruments that can promote biomass pyrolysis and gasification.

12.2. INTRODUCTION

Modern energy infrastructures supplying robust energy services such as electrical power and transportation fuels are pillars of any successful economy. Petroleum production depletion and concern about anthropogenic climate change are drivers of a shift from the current global petroleum economy to a more sustainable economy based on renewable energy sources and advanced conversion technologies.

Biomass is the oldest renewable CO₂-neutral energy source used by mankind. The bio-refinery concept, based on principles similar to a conventional petroleum refinery, has been developed to utilize bio-energy as efficiently as possible. The basis of a bio-refinery is “polygeneration”: i.e. parallel production of several commodities—such as electrical power, biofuels and chemicals—from the same feedstock. Pyrolysis and gasification are key technologies within this concept, since they convert solid wet biomass of low calorific value into intermediate solid, liquid and gaseous fuels that can be further developed to refined high-calorific fuels. Second-generation biofuels, such as Dimethyl Ether (DME), Fischer-Tropsch diesel and gasoline, are of significant interest in this context.

Africa, due to its largely tropical climate and its vast cultivable land area, offers immense bio-energy potential. Attracting investment to Africa for developing a sustainable energy infrastructure, including bio-refineries, could be a key factor in poverty alleviation efforts. However, there are many constraints—economic, institutional, social, environmental and technical—that must be considered if this vision is to be realised.

The purpose of this paper is to provide an overview of pyrolysis and gasification and evaluate the opportunities and barriers associated with improving the efficiency and socio-environmental sustainability of these technologies.

12.3. BIOMASS IS THE DOMINANT RESOURCE IN DEVELOPING COUNTRIES

In developing countries, an estimated 1.6 billion people have no access to electrical power or other modern energy services (see Figure 12-1). This problem is most serious in the rural areas, especially in Sub-Saharan Africa (SSA) (Ljung 2007). For example in Ethiopia, only 6 % of households are connected to the electrical grid (GTZ, 2008).

Developing countries are extremely vulnerable to increasing petroleum prices. SSA countries together account for less than 2% of global oil consumption, but their economies have been affected more than any other region by the latest oil price surge (Jacobsson 2007). Between 2004 and 2007, the annual net oil importing bill of 14 SSA countries³⁶ together increased by US\$11 billion, which is equivalent to 120 % of the total development assistance they receive annually (WEO 2007).

Meanwhile, all Millennium Development Goals (MDGs) (poverty and hunger eradication, health, primary education, gender equality, economic development and cooperation, and environmental sustainability) can be related to access to modern energy services. Thus, energy policies in Africa should be focused on electrifying and providing sustainable fuel supply, for example in the form of biofuels (Ljung 2007).

³⁶ Benin, Botswana, Eritrea, Ethiopia, Ghana, Kenya, Mozambique, Namibia, Senegal, S. Africa, Tanzania, Togo, Zambia, Zimbabwe

Figure 12-1: Population without electricity, millions of people

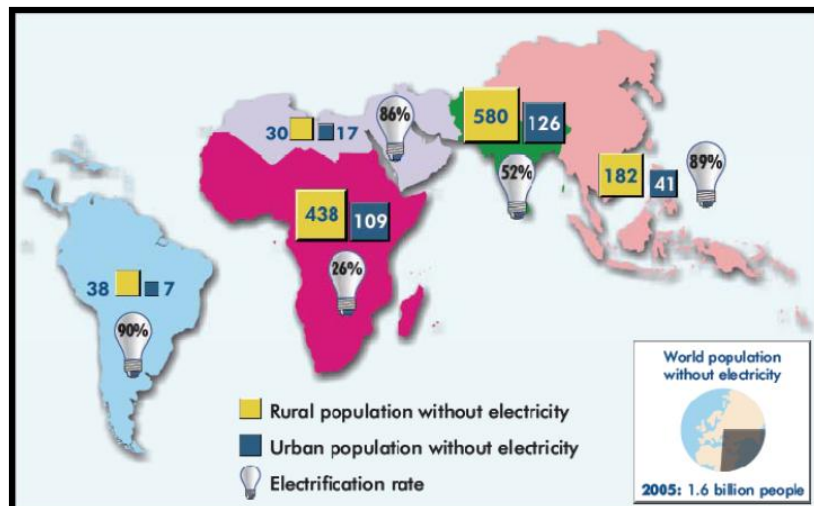

Source: WEO (2007)

Globally, biomass provides 14% of the total energy supply and is predicted to be a major source in the energy mix of the future (WEO, 007). In developing countries, about 2.4 billion people are dependent on so-called “traditional biomass”: solid wood, twigs and dung, used primarily for cooking (Ljung 2007). Consequently, poor indoor air quality, caused by incomplete combustion of biomass leading to emission of CO, Volatile Organic Compounds (VOC) and soot, causes an estimated 1.3 million deaths every year, more than malaria (WEO 2007). CO is an odourless poisonous gas, directly lethal. VOC and soot cause respiratory diseases.

Of the total primary energy supply in Africa, traditional biomass accounts for 59%, providing fuel to 320 million Africans. According to the International Energy Agency (IEA), this number is predicted to increase by a further 54 million Africans by 2015 (Ejigu 2008). The main reasons for this trend are: (i) Africa has the world’s highest population growth rate (2.5% annually); and (ii) relatively slow economic growth and associated failure to create modern energy services.

The critical role of biomass in achieving the MDGs in Africa is beyond any doubt. Of Africa's 840 million hectares of cultivable land, only 27% is cultivated today, compared with 87% in Asia (Ejigu 2008). Thus, given appropriate socially and environmentally responsible policy measures, Africa’s bio-energy potential is immense. In terms of energy, this potential is estimated to be 56 EJ per year (Larson 1993). In 2006, Africa’s total energy consumption (all energy sources included) was 19 EJ (or 453 Mtoe), equivalent to 5.6% of world’s total energy consumption (IEA 2008).

12.4. THE BIO-REFINERY CONCEPT IS ESSENTIAL FOR CREATING A BIO-BASED INDUSTRY

In a bio-refinery, biomass conversion processes and equipment are integrated to produce fuels, electrical power and chemicals as efficiently as possible. The concept is analogous to today’s petroleum refinery, which produces multiple fuels and products from petroleum (see Figure 12-2). Bio-refineries have been identified as the most promising route to creating a new domestic bio-based industry (NREL 2008). The IEA Bio-energy Task 42 defines the concept as follows: “Bio-refinery is the sustainable processing of biomass into a spectrum of marketable products and energy.”

Figure 12-2: The bio-refinery is analogous to today's petroleum refinery

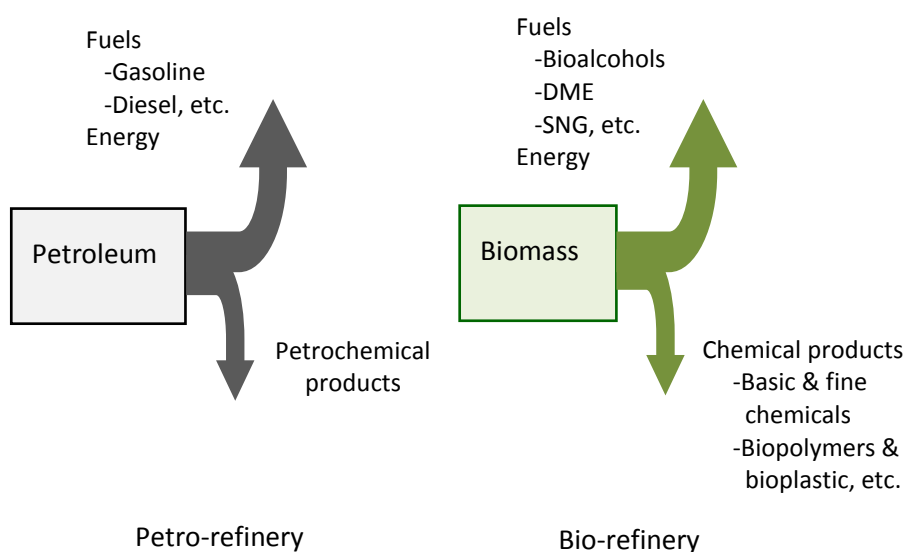

Source: van Ree and Annevelink (2007)

Biomass resources are geographically dispersed and heterogeneous in nature. Other common features of these resources include: complex chemistry; high moisture content; and low energy density (also referred to as calorific value or heating value). For example 1 m³ of un-dried wood chip has a heating value less than 1/10 of that of crude oil.

Table 12-1 shows the average heating values of dry wood, pyrolysis-oil, synthesis gas and most common fossil fuels. Wood, energy crops, agricultural and forestry residues, peat, black liquor from the pulp industry and organic industrial and household wastes are included in the biomass family. By producing multiple products, a bio-refinery can maximize the value derived from the biomass feedstock. The following example is given by the US National Renewable Energy Laboratories (NREL):

“A bio-refinery might, for example, produce one or several low-volume, but high-value, chemical products and a low-value, but high-volume, liquid transportation fuel, while generating electricity and process heat for its own use and perhaps enough for sale of electricity. The high-value products enhance profitability, the high-volume fuel helps meet national energy needs, and the power production reduces costs and avoids greenhouse-gas emissions.”

Table 12-1: Average heating values of dry wood compared to fossil fuels

Fuel	Higher Heating Value (HHV)
Air-dry wood	11 MJ/kg
Bone-dry wood	18 MJ/kg
Coal	22 MJ/kg
Natural gas	49 MJ/kg or 39 MJ/Nm ³
Synthesis gas	12 MJ/Nm ³
Crude oil	38 MJ/l
Pyrolysis-oil	19 MJ/l

Source: ETB (2008)

The performance of a bio-refinery relates to the following factors (Van Ree and Annevelink 2007):

- **Cost and economics:** The production cost is the sum of the following costs: capital, labour, feedstock, internal consumption of power, water, etc. Bio-refineries, much like petroleum refineries, employ complex processes that require a high capital cost. Increasing size leads to decreasing specific capital cost (e.g. cost per kWh electricity). However, with increasing size, feedstock supply and logistics become a greater challenge.
- **Yield:** Because of the biomass characteristics, high overall efficiencies are essential in profitability. As noted earlier, biomass has a low heating value and requires extensive pre-conditioning such as drying and grinding, consuming a considerable amount of energy.
- **Environmental impact and carbon balance:** A bio-refinery consumes a large amount of biomass, imposing changes on the local flora and fauna while reducing CO₂-emission. The corresponding cost of the environmental impact and carbon saving contributes to its overall economic performance.
- **Social aspects:** Modern bio-energy infrastructure is expected to improve people's living standards, release women and children from the heavy duty of collecting fuel, create new employment opportunities, and more. The value of these factors must be added to the bio-refinery's marketable commodities.

12.5. PYROLYSIS AND GASIFICATION ARE KEY TECHNOLOGIES IN THE BIO-REFINERY CONCEPT

Figure 12-3 summarises the available routes for converting biomass to useful commodities. Power plants which burn biomass only or a mixture of biomass and coal connected to a steam cycle (Rankine) for co-generation are commercial and common in Scandinavian countries where they are subsidized with green certificates. While this route is attractive for reducing CO₂ emissions, its electrical efficiency is quite low. Consequently, in regions with no or low heat demand its economic performance is doubtful.

Fermentation of cellulosic biomass to ethanol is probably the only sustainable large-scale ethanol production method since it does not compete with food production (in contrast to grain-based ethanol). However, this technology has just recently been demonstrated and the issues of overall efficiency and economics have not been resolved.

Biogas production through anaerobic digestion is a relatively low-cost, simple technology that can be scaled down to household sizes. However, this process is quite slow and not the best option for cellulosic biomass, since cellulose, comprising almost 50% by weight (dry wood) of this type of biomass, is resistant to enzymatic break-down.

Mechanical conversion (pressing) of oily seeds, such as rape and jatropha seeds, produces bio-diesel and provides an important fuel market. However, there are economic and environmental uncertainties related to large-scale production of bio-diesel that must be resolved. These uncertainties include: high production cost – 1.5-3 times the price of fossil diesel, reported by Enguidanos *et al.* (2002); lower energy content in bio-diesel leading to higher consumption; cold-start problems in diesel engines; high water and nitrogen requirements for oily seeds production, etc.

Figure 12-3: Principal bio-energy conversion routes and high-value products

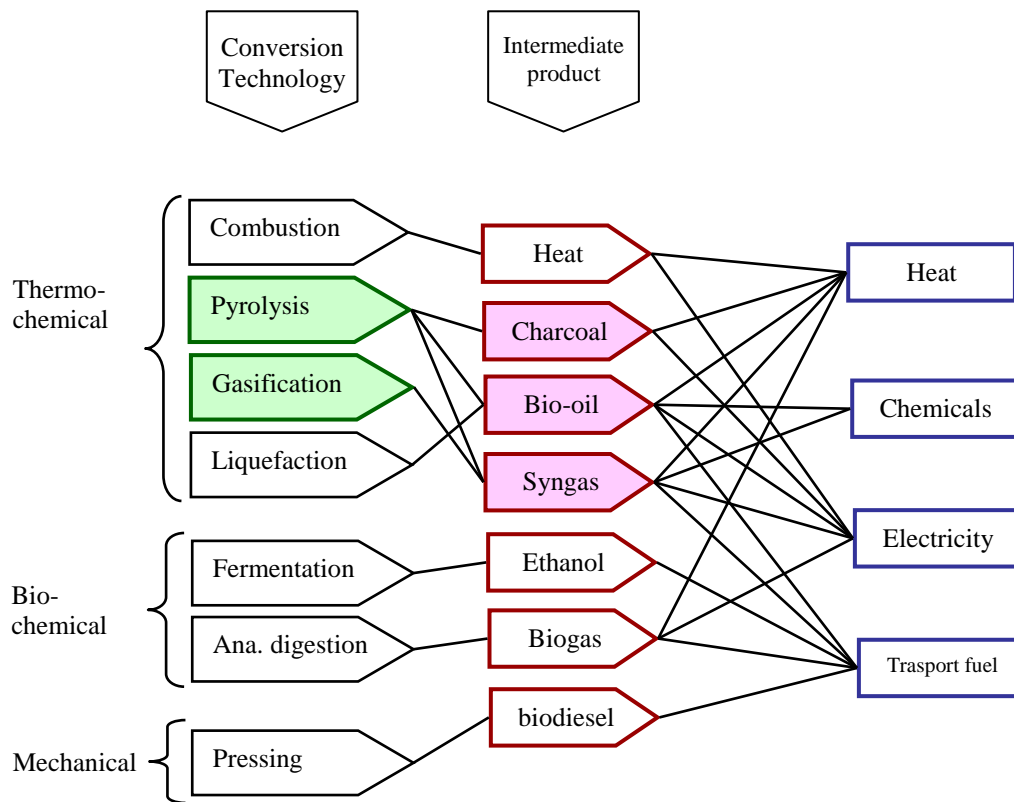

Source: UNDP-UNEP (2009, with modifications)

Conversion of biomass to increasingly important liquid fuels can be carried out in three ways: direct biomass liquefaction; fast pyrolysis; and gasification to syngas³⁷ followed by catalytic conversion to liquid fuels. The last process is also called indirect liquefaction.

In direct biomass liquefaction, the feedstock is put in contact with a catalyst at elevated temperatures in the presence of added hydrogen. The product is a synthetic oil, or bio-oil.

Pyrolysis and gasification are thermo-chemical conversion technologies that decompose biomass and its residues into valuable intermediate products. In a bio-refinery, these products can be further processed to high-quality commodities such as solid, liquid and gaseous fuels and refined chemicals. Liquid transportation fuels are of growing interest since they are easy to transport and store and because the infrastructure, such as pipelines and pumping stations, already exists. In Figure 12-4, the emerging liquid fuels are summarised and brief notes on their market maturity are given for comparison.

³⁷ The output product from a gasifier is the raw gas or producer gas, containing H₂, CO, CO₂, N₂, CH₄ and impurities such as tar, NH₃, metal chlorides and sulphides, particles, etc. After gas cleaning and conditioning, the main components remaining are H₂, CO and N₂. This gas is the synthesis gas also called 'syngas'.

Figure 12-4: Liquid fuels from biomass

Fuel	Source	Benefits	Maturity
Grain/Sugar ethanol	Corn, sorghum, wheat, sugarcane	- High-octane fuel for gasoline blends - Widely available renewable sources	Commercially proven
Bio-diesel	Vegetable oils, fats, greases	- Reduces emissions - Increases diesel fuel lubricity	Commercially proven
Green diesel and gasoline	Organic oils and fats, blended with crude oil	- Superior feedstock for refineries - Low-sulphur fuels	Commercial trials in Europe and Brazil
Cellulosic ethanol	Grasses, wood chips, agricultural residues	- High-octane fuel for gasoline blends - Probably only viable scenario for sustainable ethanol production	Demo-plant in Sweden, commercial demonstration in US by 2012
Butanol	Corn, sorghum, wheat, sugarcane	- Low volatility, high energy-density, water-tolerant alternative fuel	Commercially planned by BP & DuPont
Pyrolysis bio-oil	Any lignocellulosic biomass	- Refinery feedstocks, fuel oils, a future source of aromatics and phenols	Several commercial facilities for energy & chemicals
Syngas liquids	Various biomass & organic waste	- Can integrate biomass sources with fossil fuel sources - High-quality synthetic liquid fuels	Demonstrated on a large scale with fossil fuels, commercial biomass projects under construction
Diesel/Jet fuel from Algae	Microalgae grown in agricultural systems	- High yield per hectare, an aquaculture source of biofuels - Can be employed for CO ₂ capture	Demonstrated at pilot scale in 1990s
Hydrocarbons from Biomass	Biomass carbohydrates	- Synthetic gasoline, diesel and petroleum products	Laboratory-scale academic research

Most mature

Least mature

Source: NREL (2008)

12.5.1. FEEDSTOCK

Fuel flexibility is one of the prominent advantages of pyrolysis and gasification processes. In addition to biomass, which is the focus of this paper, carbon-rich non-renewable industrial and municipal solid and liquid wastes, petrochemical by-products, used tyres, car residues, and many other sources can be pyrolyzed and gasified.

A list of main biomass resources is given below. Feedstock specifications and preparation are described under the headings of each specific technology in the subsequent sections:

- Wood
- Forestry residues: branches, bark, tops, leaves
- Wood, paper and pulp mill residues and waste
- Paper sludge
- Black liquor
- Agricultural residues and waste: straw, cotton trash, rice hulls, corn cobs, olive seeds, nut shells, etc.
- Industrial solid organic waste
- Municipal solid organic waste
- Energy crops: woody crops such as the members of *Populus* and *Salix* genera; and herbaceous crops such as switchgrass.
- Weeds
- Bagasse
- Poultry litter
- Abattoir litter
- Dairy litter
- Manure
- Peat

The general idea of energy crop cultivation is to use marginal land or land not suitable for effective food production, thereby eliminating food substitution and food price increases. For this reason, grains are not considered as fuel in this paper.

Organic compounds constitute 88-99.9% of biomass on a dry basis. The average composition for dry wood is shown in Table 12-2. The inorganic portion is usually small and includes alkali (Na, K), earth alkali (Mg, Ca) and traces of other compounds (S, Cl, N, P, Si, Al), heavy metals (Cd, Zn, As, Pb, Cu, Hg). Alkali requires special attention and measures in thermal conversion processes since it affects the ash composition and may cause bed agglomeration, hot corrosion and particle emissions. Chlorine and sulphur may induce corrosion problems and catalyst poisoning (Zanzi 2001).

Table 12-2: Average composition (percent by weight) of dry wood

	Cellulose	Hemi-cellulose	Lignin	Extractives
Soft wood	40-45%	20%	25-35%	1-10%
Hard wood	40-45%	15-35%	17-25%	1-10%

Biomass is more reactive than coal, which is currently used in several commercial gasification processes. Thus, biomass can be pyrolyzed and gasified at lower temperatures than coal (Zanzi 2001).

Biomass requires specially-designed solids handling, drying, feeding systems and flexible reactors. The fibrous nature of herbaceous feedstocks means they are more difficult to handle than woody biomass. Another frequently encountered problem is the low-ash fusion temperatures of certain biomass types, particularly under reducing conditions, which require special care in the design and operation of biomass pyrolyzers and gasifiers (Babu 2005).

IEA Bio-energy describes the feedstock costs associated with biomass energy as follows below (IEA, 2003):

“Feedstock costs vary depending on the type of biomass and the transport distance. Bulky biomass tends to be more expensive than compact biomass. The most economical condition is when the energy is used at the site where the

biomass residue is generated (e.g. at a paper mill, saw mill, or sugar mill). Feedstock costs usually increase disproportionately above a certain level of biomass needed. Therefore, the upper limit of a biopower plant is between 30 and 100 MW, depending on the geographical context and the sources of feedstock.”

Feedstock costs for waste pyrolysis and gasification are different, since the feedstock is either zero-cost or it becomes a source of revenue (“tipping cost”) to the plant owner. There are also environmental benefits, such as eliminating these polluting substances from landfills.

12.5.2. PYROLYSIS

Conventional pyrolysis is a simple, low-cost technology capable of processing a wide variety of feedstocks. By heating biomass in the absence of oxygen, pyrolysis produces a gas mixture, charcoal and liquid fuel known as pyrolysis oil, or bio-oil. Pyrolysis is also the first step that occurs in both gasification and combustion processes, one that is followed by partial or total oxidation of the fuel (Bridgewater 2004).

There are essentially two different pyrolysis modes: slow pyrolysis (also called carbonisation) and fast pyrolysis or flash pyrolysis, with significantly different process conditions and outputs. Lower process temperature and very long solid residence time favour the production of charcoal. High temperature and moderate vapour residence time increase the biomass conversion to gas; moderate temperature and short vapour residence time are optimal for producing liquids (Bridgewater 2004). The product distribution obtained from different modes of pyrolysis and gasification is summarized in Table 12-3.

Table 12-3: Typical product yields (percent by weight, dry wood basis) obtained by different modes of pyrolysis

	Conditions	Liquid	Char	Gas
Slow Pyrolysis	Low-moderate temperatures (~ 400°C) Very long solid residence time	30 % (mostly water)	35 %	35 %
Intermediate	Moderate temperatures (~ 500°C) Moderate hot vapour residence time (~ 10-20 seconds)	50 %	20 %	30%
Fast Pyrolysis	Moderate temperatures (~ 500°C) Short hot vapour residence time (~ 1 seconds)	75 % (mostly organic)	12 %	13 %
Gasification	High temperatures (> 800 °C) Long hot vapour residence time	5 % tar	10 %	85 %

Source: Bridgewater (2004, with modifications)

Slow pyrolysis for charcoal production is a well-known commercial technology, while fast pyrolysis for pyrolysis-oil and other complex fuels is still under development. As described earlier, pyrolysis-oil production is currently attracting considerable attention.

SLOW PYROLYSIS

If biomass is heated to approximately 400°C in the absence of oxygen, slow pyrolysis will start to occur. Almost any sort of carbon-rich organic material and waste can be considered for slow pyrolysis. Only the volatile compounds in the biomass will decompose and turn into a gaseous mixture (producer gas), which comprises 35% by weight of the outputs. The remaining organic compounds emerge as charcoal, also 35% by weight. Biomass contains roughly 60% volatile

compounds, compared with less than 40% for coal. This makes biomass more reactive than coal and easier to pyrolyze (Zanzi 2008).

In Figure 12-5, the basic principle of slow pyrolysis is shown. A stream of biomass is fed to the pyrolysis kiln and producer gas and charcoal are produced. The producer gas is composed of combustible gases, including mainly H₂, CO and CH₄ but also N₂ and CO₂ and lower molecular weight hydrocarbons. This gas is cleaned by a series of operations before being recycled back to the plant or exported. A portion of the gas is combusted and used as a heat source for the pyrolysis kiln itself and to dry the incoming feed material. The excess syngas represents the net energy output and can be utilised as fuel for an engine, a gas turbine or an industrial boiler, or as feedstock in a bio-refinery. The charcoal produced can also be utilised as fuel in an industrial boiler or for soil enrichment and CO₂ sequestration in soils.

Figure 12-5: Slow pyrolysis principle for syngas production

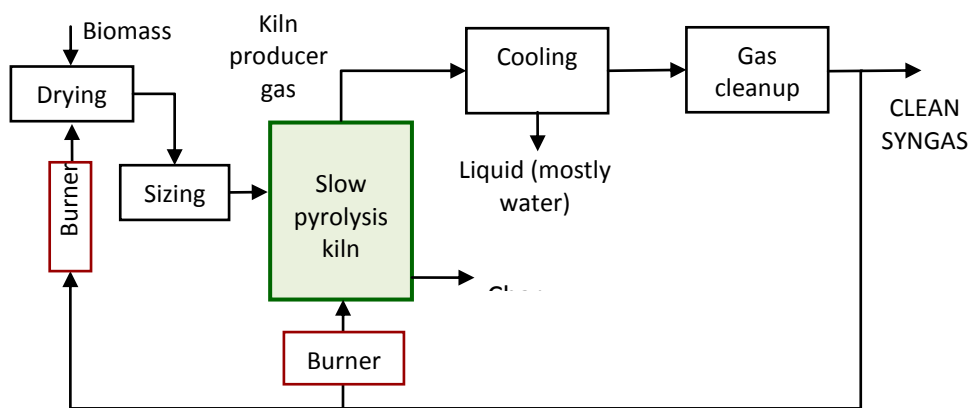
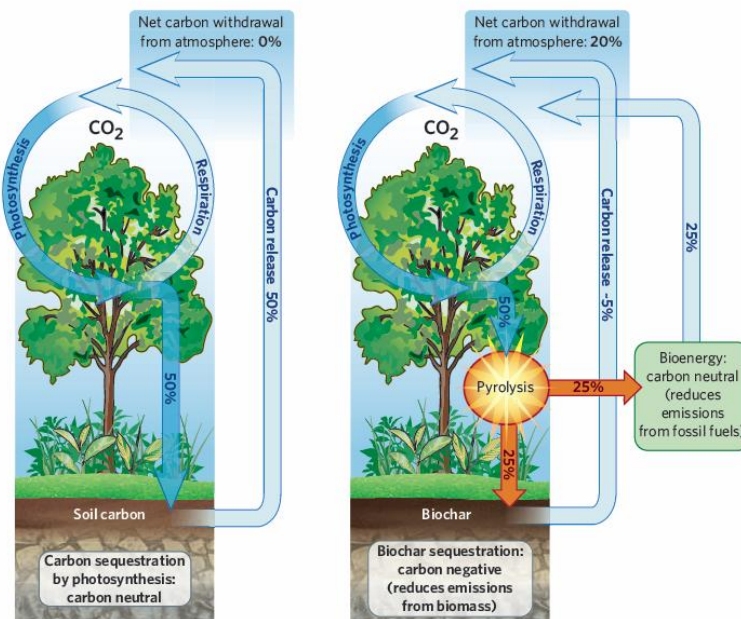

Figure 12-6: Bio-char CO₂ sequestration



Source: Lehmann (2007)

Charcoal from biomass, also called bio-char, has twofold higher carbon content than ordinary biomass. Bio-char also locks up rapidly decomposing carbon in organic plants in a much more stable form, in fact orders of magnitude more stable. Given a certain amount of carbon that cycles annually through plants, half of it (the other half is bound in the produced syngas, see Table 12-3) can be taken out of its natural cycle and sequestered in a much slower bio-char cycle via slow pyrolysis (Figure 12-6). So, bio-char production and blending in the soil directly removes CO₂ from the atmosphere. Bio-char has been reported to improve the structure and fertility of soils, enhance the efficiency of fertilizers and decrease the fertilizer run-off (Lehmann 2007).

OPPORTUNITIES AND BARRIERS FOR SLOW PYROLYSIS OF BIOMASS

Slow pyrolysis provides charcoal for cooking for millions of people in developing countries. Further, it can be used as an input in metallurgical and other industrial processes, for example in the silicon industry. Charcoal burns with much less smoke, produces less indoor air pollution, and is more easily stored and transported than wet biomass such as fuel wood. However, the production of charcoal has a low efficiency, of approximately 25 % (Kantha *et al.* 2005). Moreover, there is little incentive to make the process more effective since the feedstock for charcoal production is either freely obtained (from communal forests or by illegal means) or subsidized (usually at zero-cost) by many state governments (UNDP-UNEP, 2009). Slow pyrolysis and bio-char in soil presents a significant opportunity for capture and long-term storage of CO₂.

FAST PYROLYSIS

Similar to the slow mode, fast pyrolysis occurs in the absence of oxygen, but at higher temperatures (500°C) and significantly shorter vapour residence times. In fast pyrolysis, biomass decomposes to generate mostly vapours and aerosols and only a relatively small amount of charcoal (12% by weight). After cooling and condensation, an odourless dark brown liquid—pyrolysis oil (75% by weight)—is formed which has a heating value about half that of conventional fuel oil (Bridgewater 2004).

Practically any form of biomass can be considered for fast pyrolysis, although the feed should only contain 10-15% moisture and the optimum particle size is less than 3mm, especially in fluidised bed reactors, which will be described later. While this process is related to slow pyrolysis, fast pyrolysis is more advanced, with carefully controlled parameters to give high yields of liquid. The essential features of a fast pyrolysis process for producing liquids are summarised below (Bridgewater 2004):

- Very high heating and heat transfer rates at the reaction interface, which usually requires a finely-ground biomass feed.
- Carefully controlled pyrolysis reaction temperature of around 500°C and vapour phase temperature of 400-450°C.
- Short vapour residence times of typically less than two seconds.
- Rapid cooling of the pyrolysis vapours to give the pyrolysis-oil product

At the heart of the fast pyrolysis process is the reactor. common reactor types are the fluid bed, twin screw and rotary kiln pyrolyzers. There is no obvious best technology. Fluid beds offer robust and scalable reactors, but the problem of heat transfer at large scales is not yet resolved. Further, there is an added problem of char attrition (Bridgewater 2004).

Intensive mechanical devices, such as ablative and rotating cone reactors, offer advantages of compactness and absence of fluidising gas, but may suffer from scaling problems and problems associated with moving parts at high temperatures (Bridgewater 2004).

The main product, pyrolysis-oil, is obtained in yields of up to 75 % by weight on a dry feed basis (see Table 12-3) together with by-products, char (12%) and gas (13%), which can be used within the process to provide the process heat.

In Figure 12-7, a simplified example of a fast pyrolysis system is given. Biomass after grinding and drying is fed into the bottom of the pyrolyser reactor, in this case a fluidised bed. The syngas produced is utilized within the system.

A portion of the syngas is fired to heat the reactor externally. The remaining syngas is fed at the bottom of the reactor and fluidises the bed of biomass particles. The output from the reactor is a mixture of liquid aerosols, gases and charcoal particles. The charcoal is separated in the cyclone, and the rest of the mixture continues to the quench, where the syngas is separated from the liquid. The possible uses of pyrolysis products are shown in Figure 12-8.

Although the reactor represents about 10-15% of the total capital cost of an integrated system, most research and development has focused on it, although increasing attention is now being paid to control and improvement of pyrolysis-oil quality. The remainder of the process consists of biomass reception, storage and handling, biomass drying and grinding, product collection, storage and when relevant upgrading (e.g. to pyrolysis-diesel) (Bridgewater 2004).

Figure 12-7: Fast pyrolysis principle for bio-oil production

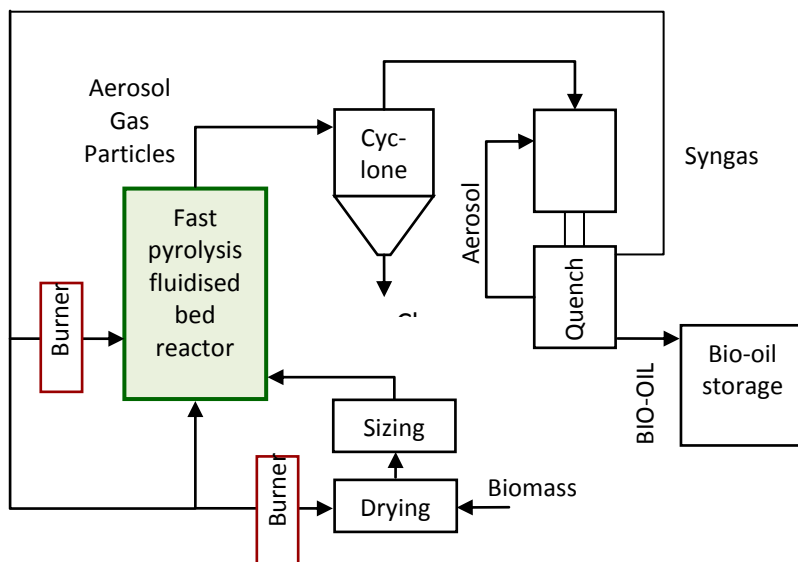

The production cost of pyrolysis-oil is estimated to be US\$ 0.40-0.7 per US gallon, assuming a feedstock cost of US\$ 50 per tonne (Brown 2008).

Figure 12-8: Uses of the fast pyrolysis products

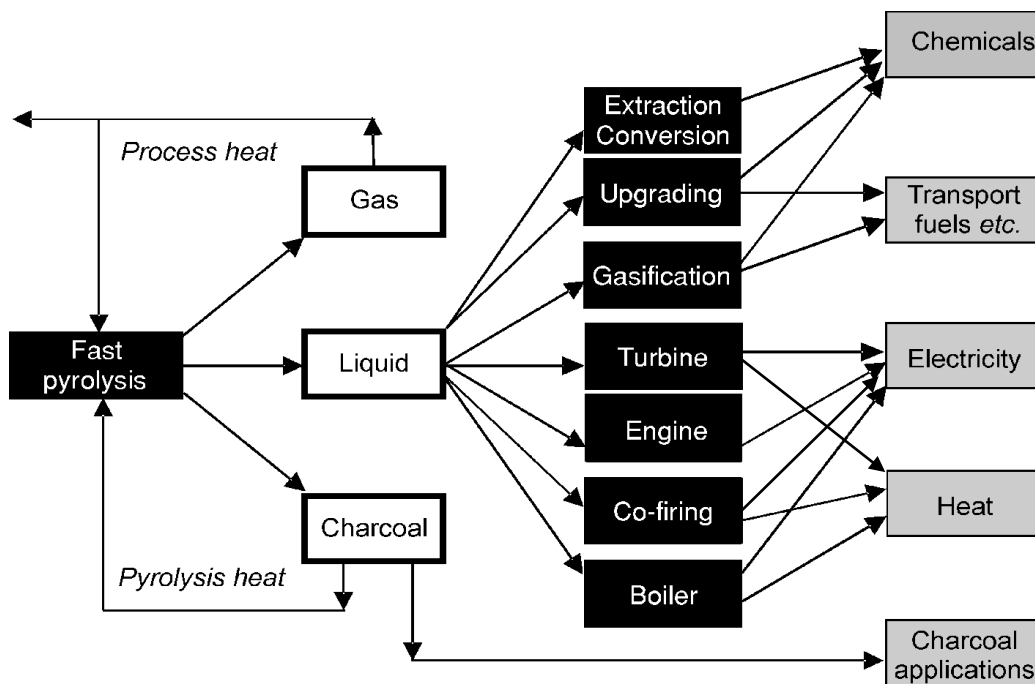

Source: Bridgewater (2004)

OPPORTUNITIES AND BARRIERS FOR FAST PYROLYSIS OF BIOMASS

Some advantages and shortcomings of fast pyrolysis are summarised below (Bridgewater 2004):

- CO₂ emission reduction: biomass is a CO₂-neutral feedstock if cultivated sustainably, and pyrolysis brings about the opportunity of CO₂-neutral electrical power and transportation fuels production.
- The liquid pyrolysis-oil product has the considerable advantage of being storable and transportable.
- Locally-produced transportation fuels and electrical power from pyrolysis-oil provide higher security of supply compared with energy services based on imported fossil fuels. However, energy derived from pyrolysis-oil is relatively expensive compared to fossil based energy (see Table 12-6).
- Pyrolysis-oil has the potential to supply a number of chemicals, like levoglucosan and hydroxyacetaldehyde that can further be converted to valuable products such as fertilizers.
- Fast pyrolysis, due to its unique products, can be an appropriate complement to other thermal conversion processes.
- It has been successfully demonstrated at small-scale, and larger demonstration plants are under way.
- Bio-oil is incompatible with conventional fuels, thus low blending is not applicable (in contrast to ethanol, where blending with gasoline is usually envisaged).
- Fast pyrolysis faces difficulties to reach commercial success as a stand-alone system. The market penetration of fast pyrolysis depends on success in integration into existing or newly developed systems where fast pyrolysis improves the overall efficiency and economic performance.

- Niche markets are likely to be the most attractive in the short term, such as utilisation of pyrolysis-oil in a marine environment as transportation fuel, where bio-oil is much less damaging than fossil oil in case of accidents.

There are a number of technical and non-technical challenges facing fast pyrolysis, including (Bridgewater 2004):

- **Cost:** the overall challenges include small-scale efficient and cost-effective power generation and heat production systems, while also taking advantage of the more economically attractive chemicals markets. Upgrading pyrolysis-oil to the quality needed in transportation fuels is still inefficient and poses several technical challenges: this route is not currently economically competitive. As noted earlier, niche chemicals, especially those produced from the whole pyrolysis-oil, such as fertilizers, or its major fractions, such as wood resins, have more interesting commercial opportunities.
- **Availability:** commercial plants that can supply pyrolysis-oil for testing and development of applications are lacking. Government policies to encourage manufacturers to implement processes and users to implement applications are needed.
- **Standardisation:** there is a lack of standards for use and distribution of pyrolysis-oil and inconsistent quality inhibits wider usage; considerable work is required to characterise and standardise these liquids and develop a wider range of energy applications.
- **Information:** much more effort should be put into information dissemination about the technology, which does not enjoy a good image from users today.
- **The environmental, health and social aspects** of this technology must be completely studied and resolved. Like gasification and combustion, emissions could include: acid gases, dioxins, furans, NO_x, SO_x, Cd, Hg, Pb, particulates, mineral ash, inorganic solid compounds, waste water, etc.

12.5.3. GASIFICATION

Gasification is the process of partial oxidation of a solid or liquid carbonaceous material by heating at temperatures above 800°C, in the presence of an oxidizing agent (air, oxygen and/or steam). The feedstock breaks down to volatile compounds, producing raw gas consisting of CO, H₂, CO₂, CH₄, water vapour and light hydrocarbons. The gas also contains tar and inorganic impurities such as HCl, NH₃ and H₂S. Figure 12-9 shows a simplified gasification process scheme after the Güssing plant in Austria. The char content and the inert bed material are separated in a cyclone and recycled to the gasifier. Most of the inorganic constituents in the feedstock are either discharged as bottom ash or entrained with the raw product gas as fly-ash.

The raw gas can be combusted immediately to produce heat and electricity, or can be cooled, filtered, and scrubbed with water or a process-derived liquid to remove condensables and any carry-over particles. Medium-temperature (350 to 400°C) or high-temperature (above 800°C) gas cleaning is also an option, which provides a fuel gas that can be used in a variety of energy conversion devices, such as internal combustion engines and gas turbines (Babu 2005).

Typically, an extra step must be taken to catalytically reform the undesired hydrocarbons (for example, undertake tar cracking) to yield a clean syngas mixture rich in CO and H₂, which in turn can be catalytically converted to produce high-value fuels and chemicals. Gas cleaning, especially tar removal, is one of the most critical steps in a gasification system and will be described later.

Figure 12-9: Simplified gasification system after the existing plant in Güssing, Austria

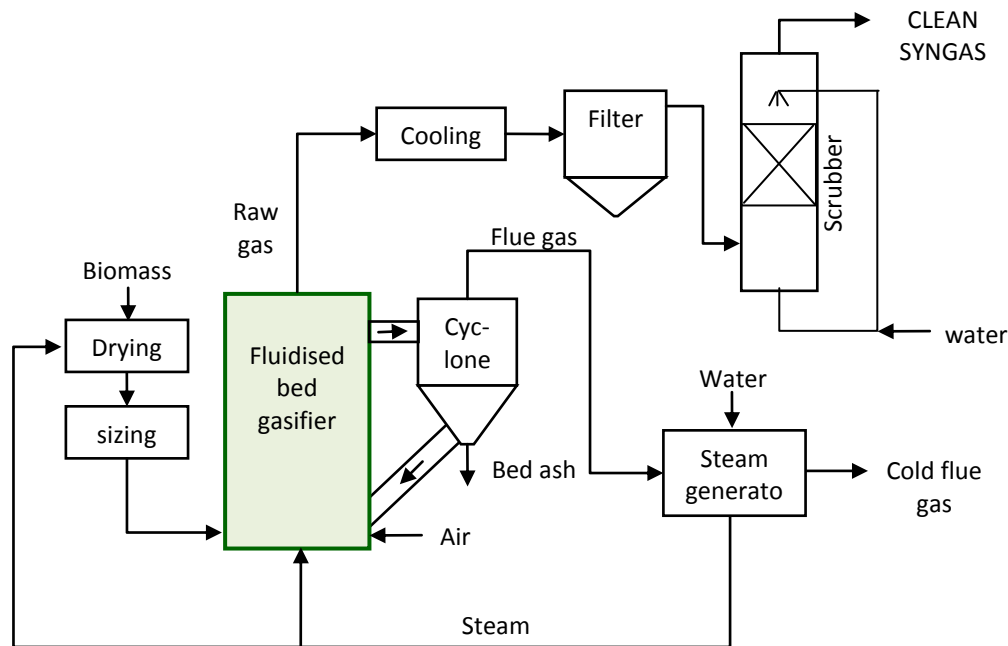

Source: Hofbauer (2008)

The composition of the gas depends on a number of parameters, such as gasification temperature and pressure, feedstock composition, reactor type and gasification agent (see Table 12-4). Generally, higher temperatures favour syngas production (i.e. higher H₂ and CO concentrations), while lower temperatures yields a higher tar and methane-rich gas. Increased pressure will usually increase the methane yield due to the equilibrium of the reactions. Further, gasification with oxygen and/or steam instead of air yields higher H₂ and CO concentrations (Tunå 2008).

Table 12-4: Typical ranges of syngas composition (percent by volume) for selected gasification conditions

	Low temperature steam blown atmospheric indirect fluidized bed	Low temperature pressurized oxygen blown fluidized bed	High temperature pressurized oxygen blown entrained flow
H ₂	35-40	23-28	29-35
CO	25-30	16-19	35-44
CO ₂	20-25	33-38	17-22
CH ₄	9-11	10-13	< 1
N ₂	< 1	< 5	< 5

Source: Hofbauer (2008)

The most prominent advantage of gasification is that of converting a solid fuel (in the case of black liquor, a liquid fuel) to syngas, which can be utilized in a number of ways as shown in Figure 12-10. This flexibility makes gasification a key technology in a bio-refinery system.

Figure 12-10: Syngas production through gasification of biomass and possible further refinement routes

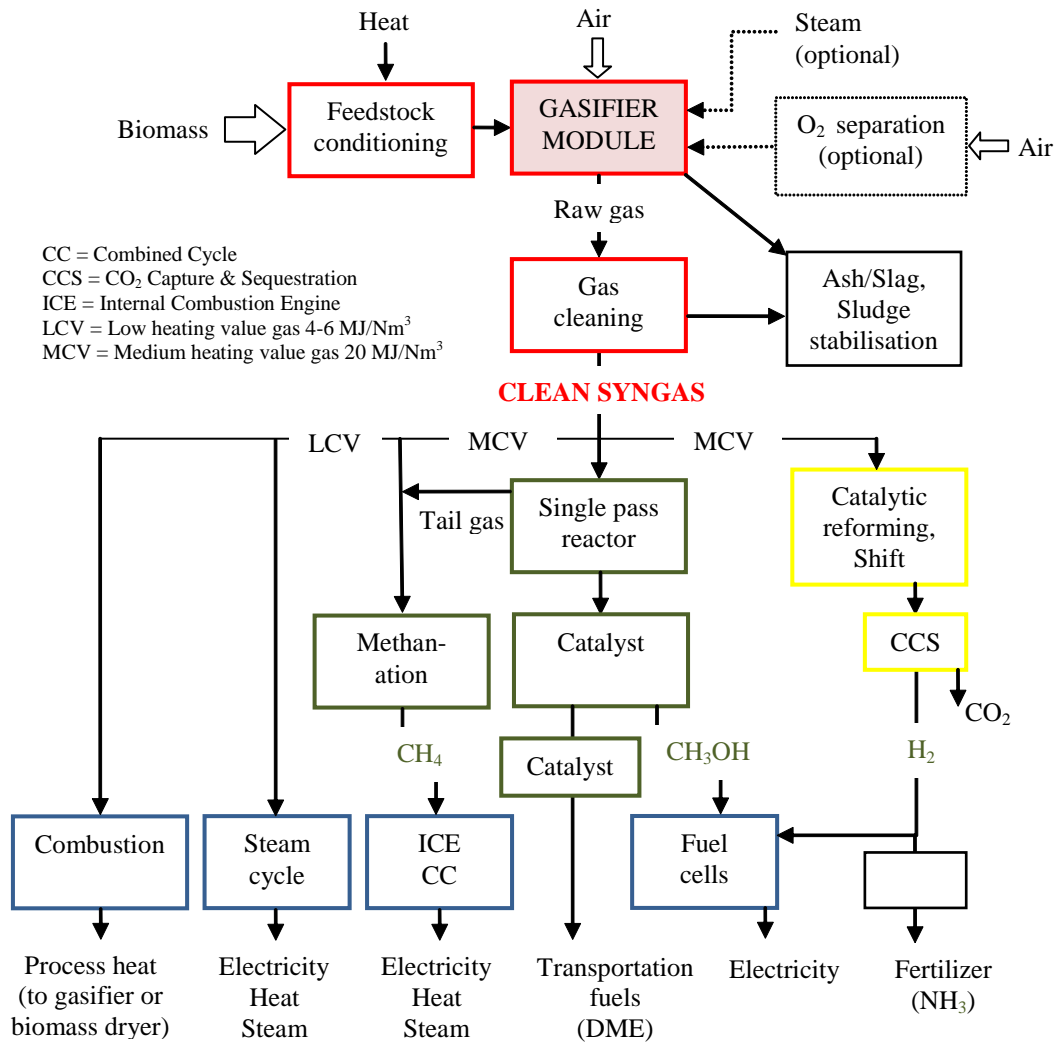

Source: NREL (2008)

GASIFIER REACTOR TYPES

There are a number of different reactor types, most of them originally developed for coal gasification. Available reactor technologies today include:

- Down-draft fixed bed, also known as co-current fixed bed
- Up-draft fixed bed, also known as counter-current fixed bed
- Fluidised bed
- Entrained flow
- Slurry bed
- Supercritical water

There are also other gasifier concepts that are not described in this paper including: Lurgi dry ash; BGL slagging; blue tower; vertical vortex; screwing two-stage (VIKING); and the plasma gasifier.

Figure 12-11: Basic process principles for two types of steam gasification

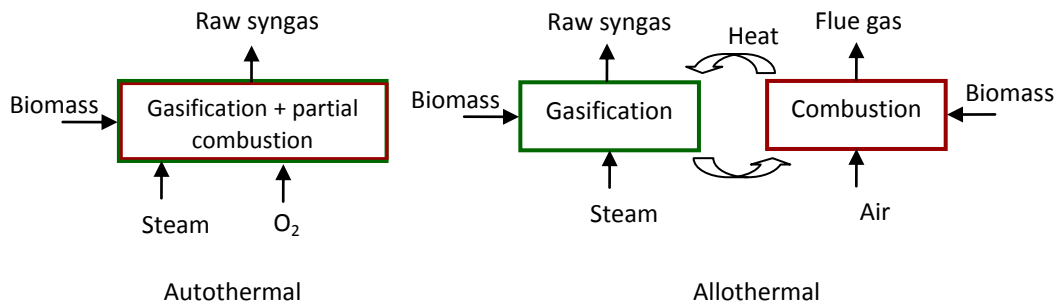

Source: Hofbauer (2008)

Gasifiers are either pressurised or built for atmospheric operation. Because of the endothermic reactions in gasification, heat must be added. This can be achieved either directly (autothermal) with partial oxidation/combustion in the same reactor; or indirectly (allothermal) by separate combustion of a portion of the feedstock or portion of the produced syngas, followed by heat transfer to the gasifier (see Figure 12-11).

When air is used as gasification medium, the product gas is nitrogen-diluted. This decreases the heating value (HV, MJ/Nm³) of the gas and increases the cost of the downstream processes as more gas needs to be processed. Using pure O₂ or O₂/steam is an alternative that eliminates the nitrogen dilution problem. However, it increases the costs significantly because of the required auxiliary O₂ separation. Below, brief descriptions of different gasifier types are given. The appropriate size range of some gasifiers and the available syngas conversion technologies are summarized in Figure 12-11. Table 12-4 gives typical syngas composition for three different gasification modes.

- **Down-Draft Fixed Bed Gasifier (DDFB):** this type of gasifier consists of a fixed bed of carbon-rich fuel which the oxidising medium flows through downwards. The gas produced is at a high temperature and the thermal efficiency is also relatively high. A significant advantage is that the formed tar levels are low (Biomass Engineering, 2008).
- **Up-Draft Fixed Bed Gasifier (UDFB):** this gasifier is similar to the down-draft type except that air, oxygen or steam flow through the bed upwards. The throughput of this method is relatively low but the thermal efficiency is similar to the down-draft type. The volume percentage of methane in the producer gas is significant, which facilitates methanation for Synthetic Natural Gas (SNG) production. Tar production is also high at normal operation temperatures, which is a disadvantage since it means that considerable cleaning efforts are required (Biomass Engineering, 2008).
- **Fluidised Bed Gasifier (FB):** a fluidised bed can be bubbling (BFB) or circulating (CFB). Fluidised beds are very common for combustion of coal, biomass and waste in medium to large heat and power plants (>5 MW) In the fluidised bed, the fuel is fluidised by the oxidising agent. The operational temperature is lower, meaning that the fuel needs to be reactive. Fluidised beds generally require careful feedstock preparation, considering moisture content and size of the solid fuel particles (Biomass Engineering 2008).

Figure 12-12: Appropriate size range of different gasifiers and syngas conversion technologies

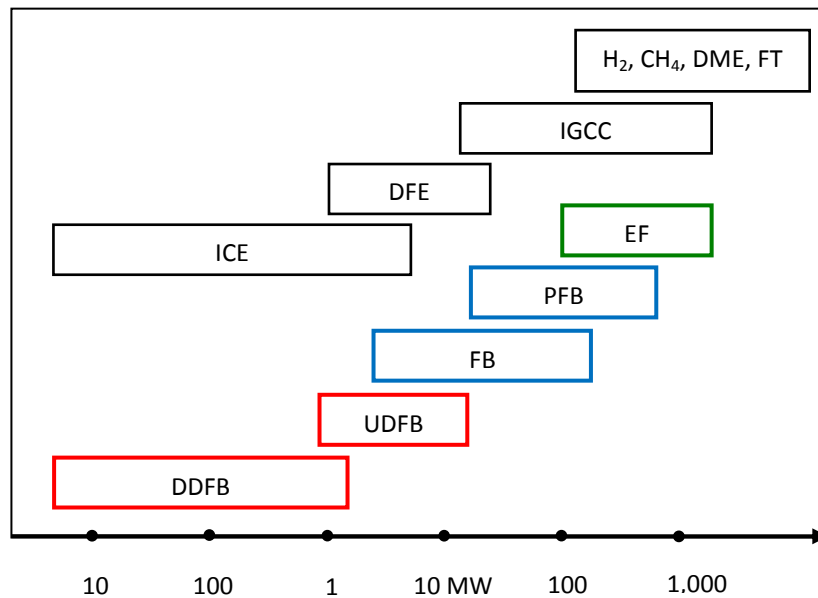

Source: Zanzi (2001), Larson (2008) and Olofsson et al. (2005)

Entrained Flow Gasifier (EF): the solid or liquid fuel fed to the entrained flow gasifier is gasified with oxygen. Reaction occurs in a dense cloud of aerosol at high temperatures and usually high pressures. A high throughput can be achieved, but the thermal efficiency is reduced as the high-temperature syngas must be cooled significantly before cleaning (Biomass Engineering 2008). Low methane and tar production but high oxygen requirements are other features of the EF-gasifier, which make it most suitable for H₂-rich gas production (Olofsson et al. 2005).

EF-gasifiers are the only attractive option for extremely large (> 1,000 MW_{thermal}) bio-refinery systems.

Indirect gasifier: with indirect gasification heat is supplied from an external source which can be any heat source of the right temperature. The goal is to transfer the heat generated in the external heater to the gasification reactor. This can be done by circulating and heating the fluidising fluid in fluidising bed reactors (e.g. in a twin-bed or dual-bed gasifier) and by heating the reactor walls in fixed-bed reactors (Karlsson and Malm 2005).

The main advantages of indirect gasification are: flexibility of heating source, which facilitates process heat and by-product recovery; low nitrogen dilution risk; and high methane content in the syngas if methanation is the primary purpose (Karlsson and Malm 2005). Methanation is the catalytic process of converting syngas to SNG which will be described later.

Supercritical Gasifier: this type of gasification is achieved in supercritical water, the critical temperature and pressure for water being 374°C and 221 bars respectively. Feedstocks with very high moisture content, 70-90% by weight, are most suitable here as a faster and more efficient alternative to anaerobic digestion. Other features include low char and tar formation due to organic solubility in supercritical water (Karlsson and Malm 2005).

The development of this type of gasifier is at an early stage. To the author's knowledge, there are only two pilot plants in the world, one in Forschungszentrum Karlsruhe in Germany and the other one in University of Twente, the Netherlands.

SYNGAS TO ELECTRICAL POWER

As noted earlier, one prominent advantage of gasification is the flexibility that syngas production provides. Syngas can be directly fired in internal combustion, stirling and steam engines for small-scale heat and power production (CHP) or in steam and combined cycles for large scale CHP. Table 12-5 shows available options for electrical power production from biomass at different scales.

Table 12-5: Electrical power production options at different sizes

System	Power output [†] (kW)	Electrical efficiency (%)	Biomass (dry mass tonne) [‡] /year	Comments
Small down-draft gasifier / ICE	10	15	74	High O&M [‡] cost Low availability Low investment cost
Large down-draft gasifier / ICE	100	25	442	High O&M cost Low availability Low investment cost
Stirling engine	35	20	177	Good availability Under develop. High cost
Steam engine	100	6	1,840	Good reliability High cost
Pyrolysis / ICE	300	28	1,183	Under development
Rankine organic cycle	1,000	18	6,311	Commercial
Up-draft gasifier / ICE	2,000	28	7,886	Commercial
Fixed grate or fluid bed boiler / Steam cycle	2,000	18	12,270	Commercial
Fluidised bed gas. / combined cycle	8,000	28	29,710	Demonstrated
Fluidized bed gas. / co-fired with coal	10,000	35	31,500	Commercial

[†] Indicative of range for application

[‡] Assumption: availability 70 % and fuel higher heating value (HHV) 20 MJ/kg

[‡] Operation and maintenance

Source: Hollingdale (2005)

Both DDFB and UDFB are appropriate technologies for small reactor sizes (5 kW-10 MW_{thermal}). In this size-range, liquid fuel production is not economically feasible (see Figure 12-12) and the option remaining is to produce heat and power in internal gas engines or dual fuel engines. In rural area in developing countries small biomass DDFB gasifiers connected to a gas engine can be economically competitive to a diesel engine running on fossil diesel – depending on the diesel price and the local availability and cost of the biomass feedstock.

The appropriate size range of atmospheric FB-gasifiers is approximately 5-150 MW_{thermal}. Above 150 MW_{thermal}, pressurised FB-gasifiers (PFB) are to prefer. Large PFBs up to 1,000 MW_{thermal} are commercially available (Zanzi, 2001).

For gasification systems larger than 15 MW_{thermal}, the combined cycle alternative for power production starts to become attractive. Gas turbines are available in a wide range of sizes, while steam turbines at small sizes (a few MW_{electrical}) have a very low efficiency. However, simple gas turbines also have quite low electrical efficiencies and are only interesting for auxiliary power production.

Converting syngas to high-value fuels only starts becoming economically feasible for gasification systems larger than 100 MW_{thermal} (see Figure 12-13). Unfortunately, that is estimated to be the upper logistical and economic limit for biomass feedstock supplies today (IEA 2003).

COST OF ELECTRICITY PRODUCTION

In this section the capital cost and the cost of electricity production for selected technologies are given. The values shown are indicative and highly dependent upon assumptions made. In Table 12-6, the specific capital cost and cost of electricity production for three different small-scale biomass-to-electricity routes are compared. In a condensing power plant electricity is the sole end-product and the generated heat does not bring any revenue.

Table 12-6: Small scale (2 MW) biomass to electricity routes, condensing

	Biomass boiler/ steam cycle	Gasification/ gas engine	Fast pyrolysis/ diesel engine
Electricity output (MW _e)	2	2	2
Electrical efficiency (% HHV)	18	33	38
Gasification efficiency (%)		73	
Liquid product efficiency (%)			65
Overall efficiency [†] (% HHV)	18	24	25
Capital cost (US\$/kW)	2,300	4,200	3,600
Cost of electricity (US¢/kWh)	11	14	15

[†] Biomass to electricity as the sole end-product

Source: IEA (2003)

By recovering the generated heat and finding an application for it (e.g. district heating) the overall efficiency and consequently the economic performance of the system can be significantly improved:

Table 12-7: Small scale (2-6.2 MW) biomass to electricity routes, co-generation

	Biomass boiler/ steam cycle	Gasification/ gas engine	Fast pyrolysis/ diesel engine
Electricity output (MW _e)	2	5	6.2
Heat output (MW)	7	6	7
Electrical efficiency (% HHV)	18	24	25
Overall efficiency (% HHV)	88	85	59
Cost of electricity (US¢/kWh)	6	9	13

Source: IEA (2003)

Table 12-8 shows the cost of electricity production in an Integrated Gasification Combined Cycle power plant (IGCC) of two different sizes. The economic performance of this system improves clearly—specific capital cost and cost of electricity production decreases—with increasing size.

Table 12-8: Medium scale (56-132 MW) gasification power plants, condensing

	High pressure direct gasifier/combined cycle	
Electricity output (MW _e)	56	132
Electrical efficiency (% HHV)	36	40
Capital cost [†] (US\$/kW)	1,700	1,370
Operating cost [‡] (US\$1000/year)	13,700	28,700
Cost of electricity (US¢/kWh)	6.3	5.4

[†] Total capital requirement

[‡] Including fuel

Source: Craig & Mann (1996)

The economic characteristics of three medium-large scale conventional power plants are given in Table 12-9, for comparison with power production gasification systems presented above.

Table 12-9: Cost of electricity production in convectional condensing power plants

	Coal boiler/ steam cycle	Natural gas/ combined cycle	Peat boiler/ steam cycle
Electricity output (MW _e)	500	400	150
Electrical efficiency (% LHV)	41	55	38
Capital cost (€/kW)	814	572	964
Cost of electricity (0.01€/kWh)	2.4	2.6	3.1

Source: Tarjanne & Rissanen (2000)

SYNGAS TO LIQUID FUELS (BTL)

As noted earlier, syngas production provides a wide range of opportunities. In addition to directly producing heat and electrical power, syngas can be converted to high-value gaseous or liquid fuels and chemicals through a number of routes. These are shown in Figure 12-13 and some of the most promising end-products are described as follows below. These end-products are included in the 2nd generation biofuels group.³⁸

Fischer-Tropsch Liquid (FTL) is synthesized by catalytically reacting CO and H₂ and is a mixture of primarily olefins and paraffins, which are straight-chain hydrocarbon compounds. Fe, Co or Ru are usually used as catalysts. FTL resembles a semi-refined crude oil. The mixture can be shifted to synthetic diesel or gasoline or further refined to jet fuel, naphtha and other fractions (Schwietzke *et al.*, 2008).

FT-fuels were first produced commercially in the 1930s in Germany from coal for use in vehicles. A coal-to-fuels programme has been operating in South Africa since the early 1950s and since the 1990s there has been renewed interest in producing FTL from natural gas. Of special interest is synthetic diesel, also called FT-diesel, with a high cetane³⁹ number, containing little or no sulphur or aromatics and which can be blended with fossil-based diesel (Larson 2008).

Converting biomass into FTL involves similar processing as for coal conversion. Driven in part by European Union Directives since 2003, which recommend that all member states have 5.75 per cent of all transportation fuel consumption (on an energy basis) from biofuels or other renewable fuels by the end of 2010, financial incentives are in place in the United Kingdom, Germany, Spain, Sweden and elsewhere to encourage bio-FTL production (Larson, 2008).

The production cost of FT-fuels is estimated to be US\$ 1.9 per US gallon, assuming a feedstock cost of US\$ 50 per tonne (Brown 2008).

³⁸ 2nd generation bio-fuels are generally accepted to be any bio-fuels other than ethanol produced from starch or sugar feedstock, and bio-diesel produced by the trans-esterification of vegetable oils and animal fats (IEA Bio-energy 2006).

³⁹ The cetane number is a measure of how effective a fuel is for use in a compression-ignition engine, for example in a diesel engine

Figure 12-13: Possible syngas to other fuel routes

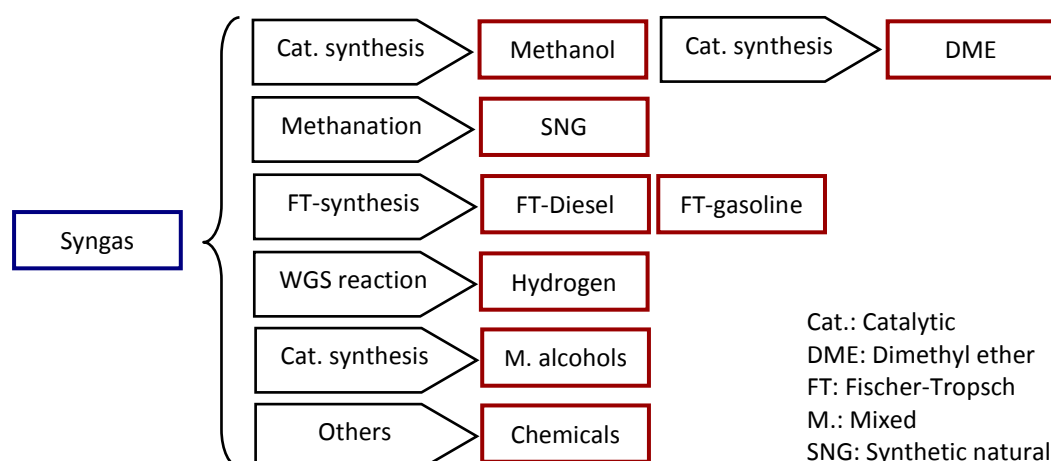

Dimethyl Ether (DME): As with the FT-synthesis, catalysts are necessary to carry out the reactions. The CO and H₂ in the syngas react to form methanol and the reaction is catalyzed by Cu/ZnO. Methanol is brought into contact with Al₂O₃ to form DME (NREL 2008).

DME is a colourless gas at normal temperatures and pressures, with a slightly ethereal odour. It liquefies under slight over-pressure. It is relatively inert, of low viscosity, non-corrosive, non-carcinogenic, almost non-toxic. Its physical properties make it an excellent diesel engine fuel due to its high cetane number and absence of soot production during combustion. It is not feasible to blend DME with conventional diesel fuel, because DME must be stored under a slight over-pressure to maintain a liquid state. However, because DME burns extremely cleanly in an appropriately designed diesel engine, an attractive application is in diesel vehicles, especially centrally fuelled fleets such as buses and delivery trucks, operating in urban areas where air pollution is most severe (Larson 2008).

Global DME production, though currently based on fossil fuels, is due to increase rapidly in the coming years, mainly as a result of large investments in China and Iran. Development of heavy-duty vehicles (trucks and buses) fuelled with DME is also underway in Sweden by Volvo and in Japan (Larson 2008).

Mixed alcohols: Syngas can be converted into a mixture of alcohols by catalytic synthesis. The process steps resemble those for making FT-liquids. A number of different catalysts can be used, but the most common is ZnO/Cr₂O₃. Mixed alcohol fuel includes a significant fraction of ethanol, plus smaller fractions of several higher alcohols (Larson 2008). Mixed-alcohol fuel has the potential to be used much the same way ethanol is used today for low blending with gasoline. These alcohols are characterised by higher volumetric energy densities and lower vapour pressures than ethanol alone, making them more attractive as a fuel or blending agent (Larson 2008).

SYNGAS TO GASEOUS FUELS

Synthetic Natural Gas (SNG): The main component in natural gas is CH₄. The existing infrastructure for fossil natural gas (pipelines, international standards, gas turbines, etc.) makes production of synthetic natural gas attractive. Methanation catalyzed by Ni-based catalysts involves a series of reactions between H₂ and CO and CO₂ to ultimately produce CH₄ and H₂O. After methanation, the gas is upgraded, meaning H₂O, the remaining CO₂ and other by-products are removed from the gas stream. The output is essentially CH₄ and is called SNG (Larson, 2008).

As with DME, CH₄ burns very cleanly and make an excellent fuel for vehicles. This is probably the most interesting use for SNG, whereas SNG for power production is economically not competitive with fossil fuels and clean syngas (Valleskog *et al.* 2008). A number of car and heavy vehicle manufacturers, such as Volvo, today provide gas-driven vehicles.

H₂ Rich Gas: The water-gas shift reaction regulates the H₂/CO ratio in the syngas. The CO is reacted with H₂O to form CO₂ and more H₂. The catalyst is usually Cu/ZnO but other catalysts can be used depending on the reactor temperature (Tunå 2008). After this reaction, the gas stream is upgraded by separating the CO₂. As with methanation, H₂ production in this context gives a unique opportunity for carbon capture and storage (CCS) and consequently, zero-emission (negative emission when biomass is gasified) systems.

Fuel cells, stationary or mobile, driven by H₂ have very high electrical efficiency, but still the costs of fuel cells are too high for a commercial breakthrough. H₂ and Hythane (a mixture of H₂ and CH₄) can also fuel gas-driven vehicles. Major disadvantages of H₂ are its low molecular weight and energy density (which makes storage and transportation difficult and costly), its chemical reactivity with container vessels, leakage problems and fire risks.

The production cost of hydrogen from biomass is estimated to be US\$ 1 per US gallon, assuming a feedstock cost of US\$ 50 per tonne (Brown, 2008)

BARRIERS FACING 2ND GENERATION BIO-FUEL PRODUCTION

The FT-fuels, DME, methanol, and mixed alcohols can be thermo-chemically produced from a range of biomass feedstocks and are not limited to protein-rich grain seeds and vegetable oils/animal fats like 1st generation bio-ethanol and bio-diesel. The production potential is therefore much larger. The energy requirements for these processes are supplied by the biomass and if the fossil fuels used in the lifecycle—mainly in the biomass production and transportation—are minimised, the GHG emission profile connected to 2nd generation bio-fuels is expected to be quite good (Deconti 2008). In Table 12-10 below the biomass to fuel efficiencies for some conversion routes are given.

Table 12-10: Biomass to fuel efficiencies based on current technology

Fuel	Efficiency (%)	Route
Grain Ethanol	38	Bio-chemical
Cellulosic ethanol	35	
Methanol	45	Thermo-chemical
Hydrogen	50	
FT-fuels	45	

Source: Brown (2008)

In Figure 12-14 the competitiveness of 1st generation bio-fuels relative to crude-oil is shown. A similar figure for 2nd generation bio-fuels is not available to the author's knowledge, but it can safely be stated that the competitiveness of 2nd generation bio-fuels, at this development stage, is lower. However, the cost of 2nd generation bio-fuels—those produced via pyrolysis and gasification included—are expected to fall much more than the 1st generation bio-fuels (see Table 12-11) due to the following two factors: (1) technical development of 2nd generation bio-fuels are at an early stage; and (2) the lower feedstock cost share of the total cost, as noted earlier. Although cellulosic ethanol in Table 12-11 is not produced through gasification, its expected cost reduction also gives a general idea of the potential of BTL-processes and product fuels.

Figure 12-14: Crude oil and 1st generation bio-fuel competitiveness

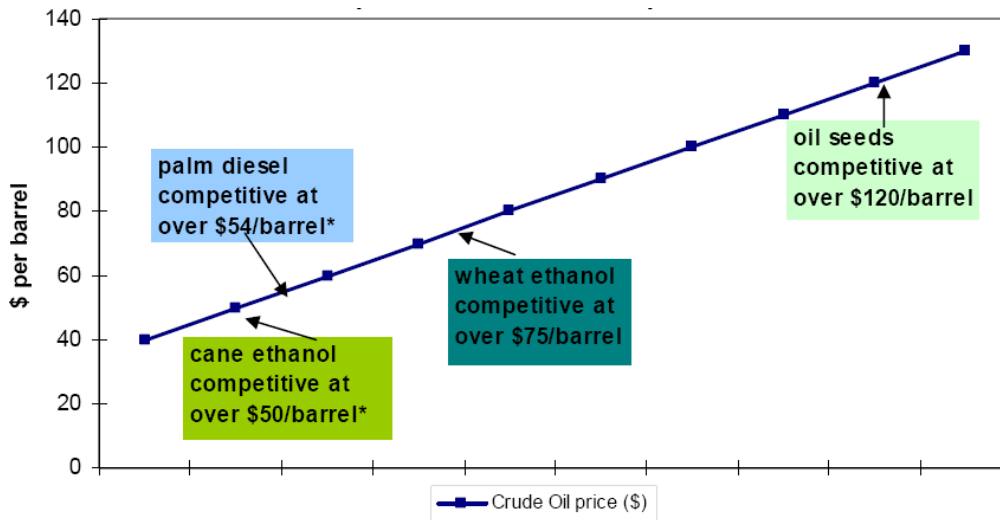

Source: Deconti (2008)

There is not a lot of independently verified information available on the BTL-processes. Information on operating costs and capital costs is scarce. It has been suggested that the capital costs could be an order of magnitude higher than the capital costs for 1st generation bio-fuels plants of the same capacity based on the 2006's cost level. While operating costs will not be dominated by the feedstock costs as they are in 1st generation plants—due to the possibility of using lower-quality feedstocks—the high capital cost will have a severe impact on the potential investment returns.

In the case of FT-fuels, the process is believed to require 4-6 kg of biomass feedstock to produce 1 kg of FT-fuel. This compares with the mechanical process of bio-diesel that produces about 1 kg of fuel from 2.5 kg of rape seeds or 5 kg of soybeans. The energy efficiency of the FT-process can range about 35-45 % depending on the gasification and synthesis technologies employed. This is quite low compared with fossil diesel. The FT-fuels have the advantage that the products are compatible with the existing diesel fuels and thus distribution system issues are largely avoided by these products (IEA Bio-energy 2006).

Table 12-11: Bio-fuel production cost in 2002 and 2030

	Cost in 2002 (€/litre)	Cost in 2030 (€/litre)	% Fall
Sugar-cane ethanol [†]	0.27	0.22	-19
Grain ethanol [†]	0.40	0.37	-8
Bio-diesel [†]	0.47	0.41	-13
Cellulosic ethanol [‡]	0.47	0.22	-53

[†] 1st generation bio-fuels

[‡] 2nd generation bio-fuel – bio-chemical

Source: Deconti (2008)

The natural gas to DME process is reported to have a relatively high conversion efficiency and it is expected that the Bio-DME would also have a good conversion efficiency compared to other biomass gasification routes. Since DME has not been widely used as a transportation fuel it will be required to move through a health, safety and environmental assessment in some countries before widespread adoption of the fuel is possible (IEA Bio-energy 2006).

IEA summarises the most important market barriers to bio-energy generally, and bio-fuels specifically, in Table 12-12 below. The barriers may overlap and there is possibly interaction between them and their effects on decisions to invest in new technologies (IEA Bio-energy, 2006).

Table 12-12: Types of market barriers

Barrier	Key characteristics	Typical measures
Uncompetitive market price	- Scale economies and learning benefits have not yet been realised.	- Learning investments - Additional technical development
Price distortion	- Current technologies may be subsidised, e.g. cost of negative environmental impacts may not be included in their prices.	- Removal of subsidies - Special offsetting taxes or levies
Information	- Availability and nature of a product must be understood at the time of investment.	- Standardization - Labelling - Reliable independent information sources
Transactions costs	- Costs of administering a decision to purchase and use equipment.	- Convenient and transparent calculation methods for decision making
Buyer's risk	- Perception of risk may differ from actual risk. - Difficulty in forecasting over an appropriate time period.	- Demonstration - Routines to make life-cycle cost calculations easy
Finance	- Initial cost may be high threshold. - Imperfections in market access to funds.	- Third party financing options - Special funding - Adjust financial structure
Excessive/ inefficient regulation	- Regulation based on industry tradition laid down in standards and codes not in pace with development.	- Regulatory reform - Performance based regulation
Capital Stock Turnover Rates	- Sunk costs, tax rules that require long depreciation and inertia.	- Adjust tax rules - Capital subsidies
Technology-specific barriers	- Often related to existing infrastructures in regard to hardware and the institutional skill to handle it.	- Focus on system aspects in use of technology - Connect measures to other important business issues such as productivity and environment

Source: IEA Bio-energy (2006)

In Tables 12-13 to 12-18, selected market barriers for three bio-fuels—DME, FT-fuels and mixed alcohols, produced via gasification and catalytic synthesis—are briefly described and compared with 1st generation bio-fuels.

Table 12-13: Second generation bio-fuels and uncompetitive price

Fuel	Comment
DME	Lower feedstock cost and higher capital costs compared to 1 st generation biofuels.
FT	Low cost feedstock, but low yield and very high capital cost offset the feedstock advantage.
Mixed alcohols	Low cost feedstock cost is offset by high capital costs and possibly catalyst costs.

Source: IEA Bio-energy (2006)

Table 12-14: Second generation bio-fuels and inefficient market organisation

Fuel	Comment
DME	This product will require a sequential decision process. Both new vehicles and new fuelling infrastructure need to be introduced at the same time.
FT	Some oil companies are involved with the product and process development. This may lower the market organisation barrier.
Mixed alcohols	Higher alcohols have properties that are closer to gasoline and may be easier to integrate into the existing system. Other properties such as octane are less attractive than the 1 st generation bio-fuels. Some processes will co-produce methanol as part of higher alcohol blend. These will be less attractive to some stakeholders.

Source: IEA Bio-energy (2006)

Table 12-15: Second generation bio-fuels and finance risk

Fuel	Comment
DME	The sequential decision process will be a concern to lenders. There will be uncertainty regarding the small size of the non-transport fuel DME markets.
FT	Very high capital cost. The FT part of the process is well known and established with feedstock such as coal and natural gas. This may lower the finance barrier.
Mixed alcohols	New technical approaches with uncertain results make these pathways less currently attractive to financial institutions than 1 st generation fuels.

Source: IEA Bio-energy (2006)

Table 12-16: Second generation bio-fuels and business risk

Fuel	Comment
DME	Very high construction and development risks related to the stage of development. Operationally will be more challenging than 1 st generation fuels.
FT	Same as DME
Mixed alcohols	High development risks. The gasification of biomass process does not scale as easily as some other chemical processes.

Source: IEA Bio-energy (2006)

Table 12-17: Second generation bio-fuels and price distortion

Fuel	Comment
DME	Should have a good GHG-emissions performance if no fossil fuels are used in the production process.
FT	Should have a good GHG-emissions performance if no fossil fuels are used in the production process. The FT-fuels have attractive combustion performance.
Mixed alcohols	May offer larger environmental benefits depending on the exact process used. There may be an impact from the fuel use as well.

Source: IEA Bio-energy (2006)

Table 12-18: Second generation bio-fuels and regulation

Fuel	Comment
DME	DME has not been commercially used as a transport fuel. There will likely be regulatory issues in many jurisdictions.
FT	FT-fuels produced from coal and natural gas are being used in the marketplace. Should be no issues with bio-fuels.
Mixed alcohols	New fuel so the regulatory burden may be higher than for the existing 1 st generation biofuels.

Source: IEA Bio-energy (2006)

OPPORTUNITIES AND BARRIERS FOR GASIFICATION OF BIOMASS

As a technology, gasification has been known for centuries but it has had limited success. Commercial coal gasifiers can be found in the metallurgical industry today and clean coal technology is under development. Biomass gasification is receiving increasing attention and is being developed in parallel with coal gasification. Figure 12-15 shows the maturity of biomass gasification and some other emerging technologies.

In rural areas in developing countries, where there is no electrical grid, small-scale biomass gasification systems can be competitive compared with other electrification options such as diesel engines. The gasification system for this purpose usually consists of a small down-draft gasifier and the electricity is generated in a gas engine. These gasification systems have been developed and manufactured in India and they can be found in many countries, including India, Cambodia, Uganda and Mozambique.

The advantages of biomass as a feedstock are well established and need no further presentation. Benefits that biomass gasification can offer are summarized below:

- **CO₂ emission reduction:** since sustainable biomass is a CO₂-neutral feedstock, gasification offers the opportunity of CO₂ capture which will result in negative CO₂ emissions.
- **High efficiency:** gasification takes advantage of the heterogeneous nature of biomass by producing a wide variety of low and high value end-products from the same feedstock. Therefore, high overall efficiencies can be obtained.
- **Feedstock flexibility:** almost all types of carbon-rich material can be gasified.
- Municipal and industrial organic solid wastes **bring additional revenue** to the plant owners since a “tipping charge” is usually attached to this type of feedstock. This means that the plant owner is paid to receive this type of feedstock from those who need to dispose of such

waste. Residues and waste are the most economic forms of biomass for power and fuel production.

- **End-product flexibility:** when planning, the production route and the equipment can be adapted to the feedstock available locally and to the end-products demanded by the market.
- **Security of supply:** as noted earlier, gasification in bio-refineries can provide the market with multiple energy services, such as electrical power and transportation fuels.
- **Synergy effects:** in countries with natural gas infrastructure, SNG can be pumped in the same pipelines, substituting fossil natural gas. Syngas and SNG can replace fossil fuels in industrial burners with minor modifications.

Figure 12-15: Maturity of selected biomass conversion technologies

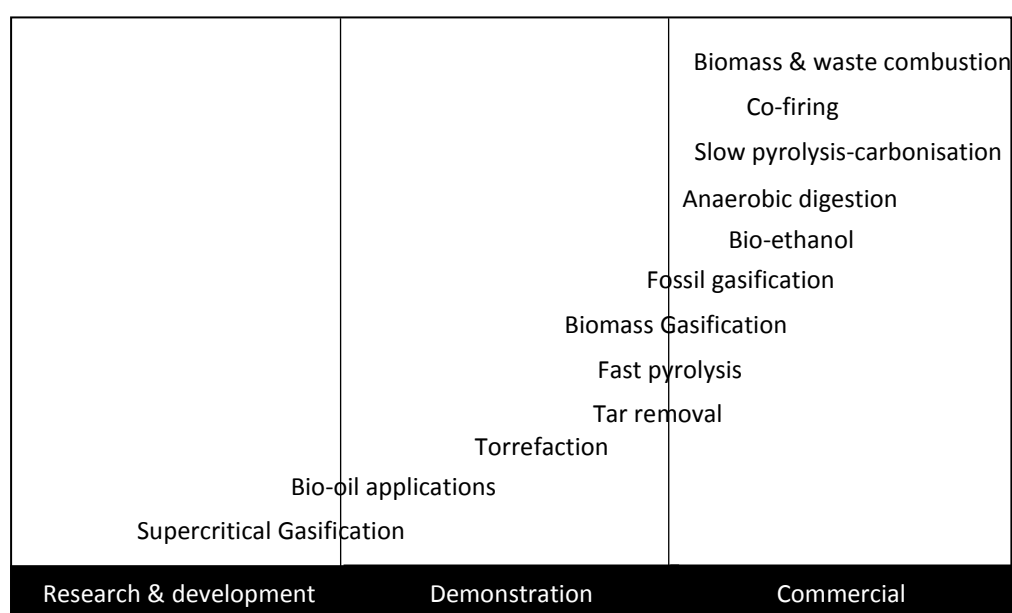

Source: Knoef (2008)

Current technical research, development and demonstration (RD&D) efforts to advance biomass gasification are concentrated in three general areas: progress in scale-up; exploration of new and advanced applications; and efforts to improve operational reliability (Babu 2005).

There are a number of technical and non-technical challenges facing biomass gasification, including (Babu 2005):

- Feeding herbaceous biomass into, and handling ash discharge from, high-pressure gasifiers remain difficult tasks. Advanced new systems can significantly improve the reliability and reduce the cost of biomass feeding.
- Real-time monitoring and timely control of critical gasifier operational parameters are essential in obtaining the right products.
- Minimising tar formation, gas clean-up and conditioning are the most critical technical challenges faced by this technology. Synthesis gas conversion catalysts (e.g. for methanol

production) require one to two orders of magnitude less tar than is generally specified for gas engines.

- Hot gas particles, tar, alkali, chlorides and ammonia removal are costly operations and affect the economy of the system significantly.
- Heat recovery is critical in obtaining high overall efficiencies. Low value heat (low-moderate temperatures) should primarily be recovered within the system, for example for drying the biomass or heating the reactor. An alternative is to connect the gasification system with outside endothermic processes.
- The required economies of scale for this type of process show that bio-refineries (for transportation fuel or hydrogen production) are most appropriate for large-scale centralised production, making feedstock supply a real logistical challenge.
- There is an absence of market pull due to competition from fossil fuels, especially with the current oil price below US\$50 per barrel (December 2008). It has been reported that 2nd generation bio-fuels will start to be competitive at a crude-oil price well above US\$100 per barrel, but again the information is scarce. However they also have the highest potential for cost reduction in the long term.
- Inadequate government policies and incentives, i.e. market push, are contributing to the lack of interest from users.
- There is no infrastructure for quality-controlled feedstock supply at a guaranteed price.
- The manufacturers of gasifiers, gas turbines and other equipment connected to the gasifier are unable to provide performance guarantees, mainly because there is not enough experience from commercial operation of biomass gasification systems.

Raw gas clean-up and syngas conditioning are, without doubt, the most challenging technical hurdles. Tar formation cause major problems and have been the focus of much attention since the 1970s. The best option to handle tar is to avoid formation in the first place or to thermodynamically destruct it inside the gasifier reactor. Nevertheless, catalytic reactors for tar cracking, operating in series with the gasifier, are also available.

Some studies show that employing calcined dolomite or olivine in the gasifier as the primary tar decomposition agent followed by a secondary tar cracking step with a Ni-based catalyst may be the best approach. Although Ni has the capability to reform or decompose condensable hydrocarbons and even ammonia at about 800°C, Ni catalysts are vulnerable to other raw gas contaminants: sulphur, chlorine, and alkali metals. Scrubbing the raw gas with an organic agent (the OLGA-process) to remove tars above the water dew point is also an alternative. The water-free, organic liquid stream can be recycled to the gasifier to thermally decompose and gasify the tars (Babu 2005).

Sulphides and ammonia (NH₃) can effectively be removed by regenerable and non-regenerable solid materials and absorption liquids. Tar aside, gas scrubbing with water or organic liquids can remove most syngas contaminants.

Staged gas cooling, followed by cyclones or barrier filters, is effective in separating alkalis and chlorides along with particles. Ceramic and sintered metal barrier filters are available alternatives, although they are too fragile for some operations. Flexible ceramic bag filters that are now being developed will offer an attractive alternative. Also, wet electrostatic precipitators have been shown to be effective. Catalytic barrier filters can decompose the tar compounds or adjust gas composition (for example, the H₂ to CO ratio) while the separation of entrained particles is in progress (Babu 2005).

Recovery of high-temperature sensible heat from the raw gas in heat exchangers is essential for obtaining a high overall efficiency and better profitability. The raw gas from the gasifier is quite corrosive, requiring special—and often expensive—heat exchanger material. The raw gas particles and tar may block the heat exchanger tubes. Also, re-absorption of CO₂ by additives and sorbents

may lead to agglomeration of entrained dust, causing blockage. These heat exchanger failures require extensive maintenance efforts, increasing the costs. The problems just described highlight the importance of designing gasifiers with minimum tar and particulates formation (Babu 2005).

Despite all the technical challenges, the main hurdle impeding take-up of biomass gasification is the insecurity of feedstock supply, particularly biomass price uncertainties (Larson 2008). There are a number of conflicts of interests embedded in this issue, including:

- **High feedstock prices are necessary to attract stakeholders to invest** and produce non-residue feedstock such as bio-energy crops.
- **Security of food supply:** bio-energy crops and food crops may compete for the same land area, potentially resulting in scarcity of food in least developed countries and increasing food prices globally. Therefore, bio-energy crops should be grown on land not suitable for food production and marginal land, which will tend to increase production costs.
- **Competition for resources such as land, water and feedstock:** in developing countries, although current bio-energy use is largely not sustainable, it is of a very low cost and a vast majority of the population are dependent on it. Harnessing bio-energy potential on an industrial scale, if not implemented appropriately, may deprive them of their only energy source. Moreover, energy crops and food production compete for finite water resources. In developed countries, most of the known biomass resources are already utilised and production is very efficient. Thus, introducing a new branch of technology that is based on the same resources will inevitably face resistance, unless the new technology is integrated within existing industries. One good example is the integration of black liquor gasification in paper milling.

12.6. SUITABLE POLICY AND FINANCIAL INSTRUMENTS THAT CAN PROMOTE BIOMASS PYROLYSIS AND GASIFICATION

Without infrastructure for quality-controlled feedstock supply at a guaranteed price, potential users will not invest in new technologies, and consequently manufacturers will not put any effort into developing them. Hence, the key for governments and global organisations is to provide sufficient incentives for creating the necessary infrastructure.

In this light, the policy and financial instruments to promote pyrolysis/gasification technologies are not different from those attributed to “bio-energy” more generally. Policies that have been implemented to promote bio-energy may be grouped as follows (UNDP-UNEP, 2009):

- **Financial incentives:** are essentially concerned with either increasing the price of competing energy sources or reducing the cost of bio-energy supply. They include: feed-in tariffs, green certificates, tender schemes, blending requirements, and differential taxation.
- **Research, development and demonstration (RD&D):** The road from an innovative idea to a ready-to-sell product or service can be very long and difficult: for example, the principles of fuel cells were known as early as the 19th century and yet large-scale commercialisation has yet to occur. Research and development to resolve the problems and demonstration of a new technology are very costly but nevertheless necessary steps towards commercialisation. The RD&D required for biomass pyrolysis and gasification were described earlier.

- **Entrepreneurial development:** is complementary to direct financial incentives. Joint ventures between international financing organisations, governments and private companies are becoming increasingly important.
- **Power purchase liberalization:** nowadays, the global energy market is dominated by a small number of large-scale energy services companies. The production of power and fuels are centralized and these companies are reluctant to allow in non-traditional suppliers. By legislatively requiring these companies to purchase bio-energy from small-scale producers (e.g. syngas-based electrical power to the national grid or blending of bio-diesel in fossil diesel), a higher demand for new bio-energy development will be created.

Today, biomass energy has low profitability and is not competitive with fossil fuels without extensive subsidies in much of the world, except maybe, off-grid small-scale electrical power production in rural areas where access to cheap biomass is abundant. The existence and the future level of these subsidies are also uncertain in the long term. Therefore, attracting financiers to invest in modern bio-energy will not be not an easy task.

Sub-Saharan Africa (SSA), in particular, faces perennial problems. In spite of its vast biomass potential, factors including inadequacy of infrastructure, lack of up-front capital, weak institutions and shortage of skills act to hinder investment flows into the region. However, SSA has enjoyed a remarkable period of economic growth (an average 6.5% annually) between 2003 and 2007 (Thaker 2008) and is drawing increasing attention from foreign capital investors, especially from emerging industrialising countries, such as China and India. In the African context, a number of funding options are available, including (UNDP-UNEP, 2008):

- **Self-financing:** despite the record economic growth noted above, the majority of African economies are capital-constrained.
- **Clean Development Mechanism (CDM):** Africa is significantly under-represented in the CDM project pipeline. By the end of 2008, of the total 4,364 CDM projects in the pipeline, only 90 were hosted by African countries, 27 of them by South Africa. CDM projects usually involve low-risk technologies, and a high-risk biomass pyrolysis or gasification project is unlikely to proceed.
- **International funding agencies:** there are a number of international agencies, such as the Global Environment Facility (GEF), the World Bank and regional Development Banks that process a high volume of funding available to poverty alleviation and environmental projects. Official Development Assistance (ODA) and Foreign Direct Investment (FDI) are other available funding sources, but, again, perceived high-risk investments such as biomass pyrolysis and gasification may not be attractive. ODA and FDI could cover some of the costs involved in developing and implementing CDM projects, subject to concerns about ODA diversion being satisfactorily addressed.
- **Microcredit:** there is not much experience of using microcredit for bio-energy promotion, however, it could be an instrument in promoting energy crops cultivation by small stakeholders.

The failure to “win over” CDM projects depends on the following two major hurdles (Oppenoorth *et al.* 2007):

- Capacity-related problems
 - Lack of capacity at national level
 - Lack of awareness of CDM opportunities

- Few examples of national (regional) successful CDM projects to emulate
- Complicated and expensive CDM procedures and bureaucratic structure
- Bundling problems with small projects
- The need to establish a new baseline and monitoring regime for each project
- Market-related problems
 - Few stakeholders willing and able to start CDM projects
 - Lack of investment capital interested in starting CDM projects in the least developed countries
 - Poor availability of funds to pay for the initial costs and for developing a project proposal (which may not even be accepted as a CDM project)
 - The need for up-front investment (to initiate the project before Certified Emission Reductions, CERs, are actually realised)

The petroleum-based economy that has created prosperity in many parts of the world today is a result of the extensive global commitment made at the beginning of the 20th century to exploit fossil fuels and to build a massive infrastructure around them. This commitment has also included significant public sector direct and indirect subsidies along the way. The inevitable shift from a petro-economy to a sustainable economy based on renewable energy sources, such as biomass energy, requires a similar global commitment once again (Babu 2005).

12.7. CONCLUDING REMARKS

Conventional biomass pyrolysis plays an important role in the SSA region because a vast majority of the population in this region are dependent on charcoal for cooking and heating. Charcoal has advantages compared with wet biomass, like fuel wood, but its production is technically inefficient. Moreover, the current government policies in many developing countries, such as free access to the wood and forestry residues, do not promote the technical development.

Generally, biomass energy has low profitability, and relatively complex technologies such as fast pyrolysis and gasification are no exceptions. The low profitability requires high total efficiencies and virtually full-load operation conditions (UNDP-UNEP 2009). These technologies become most attractive in niche markets, e.g. rural off-grid power generation or production of high-value chemicals. Integrating these technologies into existing production lines also has the potential to generate added-value commodities.

Stable economic growth for the least developed countries is directly related to the supply and use of electrical power and fuel. Jacobsson (2007) has shown that a 7% annual increase in GDP between 2008-2030 in SSA region would result in an increase in petroleum consumption from 1 million barrels per day (2004's statistics) to 3.5-4.8 million barrels per day. Thus, another increase in the petroleum price would seriously damage the economic prospects for the region.

Fossil fuel-based electrical power generation can be replaced by renewable technologies such as bio-energy, hydro power, wind turbines, geothermal power and solar cells. Fossil fuels within the transportation sector, on the other hand, are more difficult to replace. Biomass pyrolysis and, especially, gasification provide opportunities for sustainable indigenous liquid transportation fuels production, but issues such as life-cycle analysis, feedstock supply, energy crop production, sustainable land and water uses, and social effects must first be thoroughly investigated and resolved locally.

12.8. REFERENCES

- Babu, S. P. (2005) Observations on the Current Status of Biomass Gasification. *IEA Bio-energy Task 33: Thermal gasification of biomass*. Paris: IEA.
- Biomass Engineering (2008) The Clean and Renewable Energy Resource. Website (accessed 6 August 2009): <http://www.biomass.uk.com>
- Bridgewater, A. (2004) Biomass for Fast Pyrolysis, Review Paper. *Thermal Science* 8: 21-49.
- Brown, R. (2008) *Biomass Conversion: Gasification and Pyrolysis*. Mankato: Minnesota State University.
- Deconti, M. (2008) *Estimating the Cost-effectiveness of Bio-Fuels*. London: DEFRA.
- Ejigu, M. (2008) Toward energy and livelihoods security in Africa: smallholder production and processing of bio-energy as a strategy. *Natural Resources Forum* 32: 152-162.
- Enguádanos, M., Soria, A. Kavalov, B., Jensen, P. (2002) *Techno-Economic Analysis of Bio-Diesel Production in the EU: A Short Summary for Decision-Makers* (Report EUR 20279 EN). Brussels: European Commission, Joint Research Centre.
- ETB (Engineering Tool Box (2008) Tools and Basic Information for Design, Engineering and Construction of Technical Applications. Website (accessed 20 July 2009): <http://www.engineeringtoolbox.com>
- GTZ (2008) *Policy Document – Ethiopia*. Kampala: GTZ Eastern Africa Energy Resource Base. Website (accessed 20 July 2009): <http://regionalenergy-net.com>.
- Hofbauer, H. (2008) Biomass Steam Gasification: Industrial Experience and Future Prospects. *BTG Biomass Technology Group, Proceedings of 2008 International Seminar on Gasification, Vienna*.
- Hollingdale, A. (2005) *Recent Advances in Biomass Energy Technology in Europe and Application for Southeast Asia*. The Natural Resources Institute of UK (NRI). Website (accessed 20 July 2009): http://www.nri.org/projects/biomass/conference_papers/recent_advances_in_biomass_energy_in_europe.pdf
- IEA (International Energy Agency) (2008) *Key World Energy Statistics – 2008*. Paris: IEA.
- IEA International Energy Agency). (2003) *Renewables for Power Generation – Status & Prospects*. Paris: IEA.
- IEA Bio-energy (2006) *Second Generation Biofuels – a Review from a Market Barrier Perspective*. Paris: IEA Task 39
- Jacobsson, K. (2007) *Oil Use and Economic Development in Sub-Saharan Africa, MSc Thesis*. Uppsala University. Website (accessed 20 July 2009): http://www.tsl.uu.se/UHDSG/Publications/Jakobsson_Thesis.pdf
- Karlsson, S. and Malm D. (2005) *Förnybar Naturgas – Förgasning av biobränslen för framställning av metan eller vätgas*. Malmö: Svenskt gastekniskt center.
- Kartha, S., Leach, G. and Rajan, S. (2005) Advancing bio-energy for sustainable development: Guideline for policymakers and investors. *Energy Sector Management Assistance Programme, World Bank Report, 300/05*.
- Knoef, H. (2008) State of the Art of Gasification in the EU – Need for Creating Favorable Conditions. *BTG Biomass Technology Group, Proceedings of 2008 International Seminar on Gasification, Vienna*.
- Larson, E. (1993) Technology for Electricity and Fuel from Biomass. *Ann. Rev. Energy Environ.* 18: 567-630.
- Larson, E. (2008) *Biofuel Production Technologies, Status, Prospects and Implications for Trade and Development*. New York and Geneva: UNCTAD
- Lehmann, J. (2007) A Handful of Carbon. *Nature* 447: 143-144.
- Ljung, P. (2007) *Energy Sector Reform: Strategies for Growth, Equity and Sustainability*. Stockholm: SIDA.
- NREL (National Renewable Energy Laboratory (2008) *Biomass Research*. Website (accessed 20 July 2009): <http://www.nrel.gov/biomass>
- Olofsson, I., Nordin, A., Söderlind, U. (2005) *Initial Review and Evaluation of Process Technologies and Systems Suitable for Cost-Efficient Medium Scale Gasification for Biomass to Liquid Fuels*. Umeå : Energy Technology & Thermal Process Chemistry, University of Umeå.
- Oppenoorth, H., Koene, M., Staarink, I. (2007) *The Bali Guide on CDM, Towards a Sustainable CDM*. Utrecht/The Hague: Stichting Natuur en Milieu and Hivos.
- PyNe (2008) The Biomass Pyrolysis Network. Website (accessed 20 July 2009): <http://www.pyne.co.uk>
- Schwietzke s., Ladisch, M., Russo, L., Kwant, K., Mäkinen, T., Kavalov, B., Maniatis, K., Zwart, R., Shahanan, G., Sipila, K., Grabowski, P., Telenius, B., White, M., and Brown, A. (2008) *Analysis and Identification of Gaps in Research for the Production of Second-Generation Liquid Transportation Biofuels*. Paris: IEA Bio-energy.

- Thaker, P. (2008) Everything to play for – a better future for sub-Saharan Africa depends on better policies. *The Economist – The World in 2009*, pp.87-88.
- Tunå, P. (2008) *Substitute Natural Gas from Biomass Gasification*. Lund, Sweden: Lund Institute of Technology.
- UNDP-UNEP (2009) *Catalyzing Biomass Energy in Africa, UNDP-UNEP Working Paper*. New York and Nairobi: UNDP-UNEP.
- Valleskog, M., Marbe, Å, Colmsjö, L. (2008) *System – Och Marknadsstudie för Biometan (SNG) från Biomass*. Malmö: Svenskt Gastekniskt Center.
- Van Ree, R., Annevelink, B. (2007) *Status Report: Biorefinery 2007*. Amsterdam: SenterNovem.
- Zanzi, R. (2001) *Pyrolysis of Biomass – Fast Pyrolysis at High Temperatures and Slow Pyrolysis for Active Carbon Preparation*. Stockholm: Royal Institute of Technology.

13. LANDFILL BIO-ENERGY: OPPORTUNITIES AND BARRIERS

By Stephen Karekezi, Waeni Kithyoma and Oscar Onguru

Energy, Environment and Development Network for Africa (AFREPREN/FWD)

Contact: afrepren@africaonline.co.ke

13.1. ABSTRACT

The purpose of this chapter is to evaluate the opportunities and barriers associated with the use of urban waste as an energy source. Landfill bio-energy is promising because it can simultaneously reduce methane emissions and generate renewable energy in the form of biogas. Unlike those in industrialized countries, cities in developing countries generate waste rich in vegetative and decomposable materials, including human and animal waste. Three different waste treatment options are identified: anaerobic digestion, incineration, and landfill gas (LFG) production via anaerobic decomposition. Each is considered in terms of its advantages and disadvantages, economics of implementation (costs, revenues and opportunity costs) as well as technical, financial, environmental, regulatory and awareness barriers. The chapter recommends policy and financial instruments (including carbon finance) that have been (or could be) used to stimulate investment in landfill bio-energy. It observes that a number of successful LFG projects have been realized under the CDM, including in Africa.

13.2. INTRODUCTION

Biomass is a versatile energy source. It is one of the most common forms of energy used in the world today. In the developing world, where it constitutes 70-90% of energy used, common sources include trees, timber waste, agricultural residues and human and animal wastes (Business Network, 2007). Environmental and financial incentives such as carbon finance are beginning to take root: biomass energy generation is becoming increasingly economically attractive. Studies have shown that biomass has the potential to supply a large part of developing-country energy needs if effectively managed.

Biomass can be used as an energy source in a variety of ways: as a combustion feedstock in thermal power plants, furnaces and boilers (possibly in combination with coal or other fossil fuels), or as a feedstock for pyrolysis, gasification, anaerobic digestion or fermentation (liquid biofuel production).

Biomass energy can also be sourced at a number of points in the production chain. **Primary biomass** and biomass residues (those available at the farm) and **secondary biomass residues** (those released by the agro-processing industry) are currently generating considerable interest in the context of low-carbon base-load electricity generation (e.g. using bagasse) and cellulosic ethanol production.

Tertiary biomass (that which remains after the use of goods and services) has tended to receive much less attention, in spite of the important role it, too, can play in generating energy. The purpose of this chapter is to evaluate the opportunities and barriers associated with the use of tertiary biomass as an energy source, with special emphasis on landfilled tertiary waste because it can simultaneously reduce methane emissions *and* generate renewable energy – for instance, in the form of biogas generation/utilisation and organic Refuse-Derived Fuel (RDF).

The study provides an overview of bio-energy generation from landfill waste. It reviews the fundamentals of the technology, advantages and disadvantages, economics (costs, revenues and opportunity costs) of implementation, and technical, financial, environmental, regulatory and awareness barriers. The assessment also recommends policy and financial instruments (including carbon finance) that have been (or could be) used to stimulate investment in landfill bio-energy.

The scope of the study is not limited to Africa; the purpose is to learn global lessons on how landfill bio-energy technologies can be catalysed in both the developing and developed world. Examples of successful implementation of landfill bio-energy from around the world, and the enabling conditions that were needed to effect this implementation, can provide valuable insights for application in Africa.

13.3. ENERGY FROM URBAN WASTE– A REVIEW OF TECHNOLOGIES

13.3.1. URBAN WASTE

Waste is defined as "something which the owner no longer wants at a given place and time and which has no current perceived market value" (Otieno 1992). World Resources Institute (1992) defines urban solid waste (USW) production as the "household and bulky waste, as well as comparable waste from small commercial or industrial enterprises, and market and garden residues that are collected and treated by or for municipalities" (EIONET 2008).

The term "urban waste management" is typically employed to encompass all of the activities dealing with urban waste, from the point of "production" through "collection" to "disposal" (EIONET 2008).

USW is usually heterogeneous and is composed of diverse materials with varying physical and chemical characteristics. The composition and characteristics of the waste available in a given city depends on a wide range of factors such as climate, income levels, types of available foods, packaging of foods and other items, the extent of livestock in the city, sanitary facilities and the type of waste collection system. Niessen (1987), BUN (1991) and IEA (2008) stress that waste is also a reflection of prevailing socio-economic stratification. USAID (2006) also highlights the fact that differences in waste generation reflect the level of national economic development, with the developed world generating higher amounts of waste.

Data compiled by IEA (2008) indicate that, unlike cities in the industrialized countries (which mostly generate low-density wastes with low organic material, a low moisture content, and a high percentage of paper, plastics, glass and metals), cities in developing countries generate waste rich in vegetative and decomposable materials, including human and animal waste. The “State of the World” (2007) report also provides additional evidence to support this assertion. It estimates that the percentage of municipal waste that is organic in Sierra Leone, for example, is approximately 90%, compared with roughly 60% for a typical urban settlement in the United States.

Transformation of waste into energy is expected to contribute to what has come to be known as "sustainable win-win" solutions: for example, job creation, clean energy supply, a healthy environment and reduction in carbon emissions. Thus, transformation of USW – an environmental and public health liability – into cleaner energy (a high-demand commodity that is not accessible to a large proportion of people in the developing world) is an appealing approach for managing an otherwise problematic by-product of urbanisation.

13.3.2. TECHNOLOGIES FOR GENERATING ENERGY FROM WASTE

ANAEROBIC DIGESTION

Anaerobic reactors can be used for the production of methane-rich biogas from USW, human and animal waste and crop residues. The reactor can easily be adapted to digest both urban solid and liquid wastes. Anaerobic reactors utilise mixed methanogenic bacteria cultures that are characterized by defined optimal temperature ranges for growth. These mixed cultures allow digesters to be operated over a wide temperature range, from 0°C up to 60°C. Studies conducted by Haskoning and M-Konsult (1989) and the IEA (2008) show that both domestic and market wastes can be very good feedstocks for biogas production plants (Biopact 2007). The following table shows the energy recovery potential from anaerobic digestion using different sizes of biogas digesters.

Table 13-1: Comparison of Different sizes of biogas digesters

Digester Volume	Biogas Produced	Energy Content	Use
300 m ³	20 m ³	about 480 MJ	Electricity generation, cooking, lighting, running stationery engines e.t.c
10 m ³	4 m ³	about 96 MJ	cooking, lighting,
5 m ³	2 m ³	about 48 MJ	cooking, lighting,

Source: ABO (2007)

INCINERATION

One of the most direct ways of producing energy from waste is through incineration, which generates both electricity and heat in a cogeneration system. The estimated average energy

recovery potential from an incineration plant is 2.9 MWh per tonne of waste, depending on waste composition and characteristics. The efficiency of energy recovery is about 86% of the calorific value of the incoming waste (Rylander 1996), which translates into 2.5 MWh/tonne or 9 MJ/kg (Open University 1994; The Aluminum Industry 2008).

USW incinerators generate ash that represents about 10% by volume and 25-30% by weight of the waste incinerated. About 75-85% of the ash is “bottom ash”—that is, completely or partially combusted material that passes through, or is discharged from, the combustion grates. About 15-25% of the ash is fly ash, the term for particulate matter captured from flue gas by the air pollution control system.

LANDFILL GAS

Landfill gas (LFG) is produced by the anaerobic decomposition process of organic waste within a landfill. The gas produced is collected by an array of interconnected perforated pipes buried at depths of up to 20 metres in the refuse. The generation of energy from LFG depends on a number of factors, which must be known accurately if reliable estimates of energy potential are to be determined. The most important of these factors are:

- The amount of disposed municipal waste
- The content of the waste and, most fundamentally, the proportion that is organic
- The microclimate (temperature and moisture content) of the waste
- The amount of LFG that is captured
- The energy content of the LFG (generally expressed in terms of the percentage accounted for by methane)

13.3.3. COMPARISON OF TECHNOLOGIES

The key advantages and disadvantages of the three urban waste-to-energy technologies are summarized in Table 13-2. In addition, the suitability of the technologies for different sizes of cities (small to medium and large) is indicated.

Table 13-2: Summary of urban solid waste energy recovery technologies

Technology	Advantages	Disadvantages	Suitability for the city categories
Anaerobic digesters	<ul style="list-style-type: none"> • Higher output of gas • Shorter production lead time • Encourages recycling • Land usable for recreation • Good soil conditioner (digestate) as end-product 	<ul style="list-style-type: none"> • High starting capital • Fairly technology-intensive • Requires regular maintenance 	Small to medium cities
Incineration	<ul style="list-style-type: none"> • Highest volume reduction • End-product ash can be used in road construction • Better suited to low organic content, inflammable waste 	<ul style="list-style-type: none"> • Very technology-intensive • Expensive to construct • Does not encourage recycling • Requires frequent maintenance • High running costs 	Large Cities

Landfill gas recovery	<ul style="list-style-type: none"> • Long lifetime • Can be used to substitute natural gas • When sealed, area can be used for recreation • Low technology demands • Encourages recycling because sorting of wastes separates materials that can be recycled • Low cost of operation and maintenance 	<ul style="list-style-type: none"> • Needs gas distribution infrastructure • Low gas extraction rate • Long production lead time • Requires a large land area • Expensive to set up • Cannot be easily scaled down • Suitable for bio-degradable waste only • Landfills also contribute to air pollution 	Small to medium cities as well as large cities
-----------------------	--	--	--

Source: Karekezi et al. 2004

There follows a comparative assessment of the three technology options using the following four parameters:

- 1) **Waste Composition:** Key factors are the moisture content, proportion of organic waste and energy content.
- 2) **Amount of Waste Needed:** Depending on the technology option, the minimum amount of waste required for a modest energy generating plant to function efficiently and effectively.
- 3) **Area Required:** Availability of land within a given city.
- 4) **Cost of Plant:** The capital required and the operating and maintenance costs.

WASTE COMPOSITION

Waste in developing countries and, in particular, Africa is largely organic in nature and has a high moisture content (45-85%). In addition, it has a low energy content of about 900-1,200 kcal/kg (IETC 1996; Environmental Experts.com 2008). This makes it unsuitable for incineration, which requires waste with low moisture content, a high energy content of at least 1,300 kcal/kg, and low organic content (Patrick 1993; IETC 1996; Cointreau-Levine 1994). In addition, most incineration plant designs assume that waste has a calorific value of at least 2,000 kcal/kg (USAID 1988).

Anaerobic digestion, on the other hand, is suitable for processing wet organic waste, such as animal and food waste, sewage sludge and plant material (Faaij 1997; Lusk 1996; NUTEK 1997; World Resource Foundation 1995a). The appropriate solid content of the waste should be 6-10%, which requires USW to be mixed with sewage for processing in an anaerobic digester (Goodman and Walter 1991; Robinson Undated). While this option would be suitable for the organic fraction of USW, the technology is more suitable for handling liquid waste as opposed to solid waste. In addition, the inorganic fraction of the USW is not digested.

The type of waste suitable for LFG generation is controlled waste such as solid waste from households, commercial areas and industries. This does not include waste water and may exclude military and mining waste. This implies that a wide range of waste can be disposed of by this option, making it suitable for most regions in the developing world. In addition, waste that cannot be disposed of in an incinerator (inert waste) or an anaerobic digester (inorganic waste) can be disposed in landfills.

With respect to waste composition, landfilling would be the most suitable option for developing countries in general and Africa in particular. Anaerobic digestion would be the next best option since it can process organic material, which constitutes the bulk of USW in developing countries. Incineration, which demands high energy content and low moisture waste requirements and a general low organic content in the waste, all which are not characteristic of USW in the developing

world, is the least recommended option for developing countries (of the three technologies analyzed).

AMOUNT OF WASTE NEEDED

The three technologies require a minimum amount of waste for economic recovery of energy and electricity generation. Porteous (1998) estimates the minimum amount of waste required for incineration to be economically viable to be at least 50,000 tonnes per year. Cointreau-Levine (1994) estimates the amount to be at least 120 tonnes a day, translating into approximately 44,000 tonnes of waste annually which can be generated in many cities of the developing world. For example, an average African city has a waste generation rate of 0.5kg/person/day (World Resources Institute 1998); an African city with 1 million inhabitants could be expected to generate approximately 182,500 tonnes of waste per year. This is more than sufficient for incineration to represent a potentially viable energy-from-waste option—assuming, of course, that the waste is collected and can be directed to the incinerator.

According to USAID (1988), for economic recovery of LFG, the landfill must have 2 million tonnes of organic and bio-degradable waste already landfilled and an intake of 150 tonnes of waste daily. Using the waste generation estimates for African cities above, it would take approximately 11 years to have the required base load in a landfill. The daily waste generation rate would be 500 tonnes, well above the minimum required. Again, the principal caveat is that this waste would need to be collected and channeled to a landfill.

AREA REQUIRED

Of the three technologies, landfilling requires the greatest land area. USAID (1988) estimates the required land area to be about 16 hectares for a landfill that is approximately 15m deep. An anaerobic digestion plant requires less land than does a landfill. In most incineration plants, the process occurs within a single building which (except for the tall chimney stack) differs little from standard commercial premises. Since incineration plants require less land than landfilling, they are generally suitable for densely developed urban or suburban areas (USAID 1988), but due to the air quality issues and the potential health risks posed by incineration plants, it is always best to install them away from human settlements.

COST OF THE PLANT

Plant costs for the three technologies vary from country to country depending on the economic conditions, design of the plants, and whether the technology was imported, amongst other considerations. A few studies have attempted to compare the costs across the technologies. The IEA Bio-energy Annual Report (IEA 2008) and NUTEK (1997) assessed the capital costs of the three technologies and established that incineration was the most expensive, followed by anaerobic digestion and then landfilling. However, IPCC (1996) indicates that with LFG recovery, landfill costs were comparable with, and in some cases more than, those of anaerobic digestion due to the widely varying cost of land.

Pearce (1993) argues that it generally costs more to incinerate one tonne of waste annually than it does to landfill a tonne of waste annually. Figures from a CDM-financed LFG project in the Philippines show that a landfill site with a minimum daily intake capacity of 1,500 tonnes of garbage cost the Government US\$33 million to construct (Rizal, 2008).

From the above comparison, it can be seen that the easiest and most cost-effective technology that would best suit most regions of Africa and the developing world in general, in terms of waste composition, amount of waste needed, area of land required and cost of plant, is LFG technology.

The key constraints in implementing landfilling would be the upfront cost and the availability of suitable land. The other key constraints in implementing landfilling are:

- Environmental (air quality, water table, GHGs, visual beauty, etc) issues
- The need for supporting infrastructure (such as a functioning waste collection service)
- Legal and regulatory issues

13.4. LANDFILL TECHNOLOGY – POTENTIAL AND STATUS

13.4.1. FUNDAMENTALS - HOW THE TECHNOLOGY WORKS

Large municipal or industrial landfills produce gas that can be tapped to generate electricity. In the anaerobic conditions commonly found in buried waste, microorganisms that live in organic materials such as food wastes, paper or yard clippings cause these materials to decompose. This produces LFG, typically composed of roughly 50 % methane and 50 % carbon dioxide (Power Scorecard 2000; Cleantech 2009).

USW is piled into an excavation/hole in the ground (lined with permeable material so as to allow the generation of methane) and spread out as a layer. It is then compacted and covered by a soil layer. The refuse and soil layer constitute a “landfill unit”. Successive landfill units are compacted over time, until they reach a threshold amount, at which point they can potentially become a landfill energy plant (China Energy 2009). As noted earlier, for economic recovery of LFG, the landfill must have approximately 2 million tonnes of waste already land-filled (USAID 1988).

LFG is collected from landfills by drilling “wells” into the landfill, and collecting the gas through pipes. Once the LFG is processed and cleansed, it can be combined with natural gas to fuel conventional combustion turbines or used to fuel small combustion or combined cycle turbines. LFG may also be used in fuel cell technologies, which use chemical reactions to generate electricity, and are much more efficient than combustion turbines (Power Scorecard 2000).

Figure 13-1 shows a landfill site and the generation of LFG. The products of landfills include LFG (50% methane) and leachate, which is the liquid that seeps through solid waste in a landfill and contains soluble dissolved matter (EIONET 2009). Sanitary landfills are landfills that incorporate a set of measures to control gas and collect and treat leachate, and have plans for closure and aftercare.⁴⁰ For instance, sanitary landfills include an impermeable top lining (such as compacted clay and polyethylene) to mitigate environmental impacts (Johannesen and Boyer 1999).

⁴⁰ Leachate continues to be produced even after closure of landfills and must be managed by proper treatment. For example, in Brazil, leachate from closed landfills is collected, treated anaerobically and re-circulated back into the landfill (Johannesen and Boyer, 1999); or it can also be diverted into an anaerobic digester to provide additional energy.

Figure 13-1: Modern landfill site

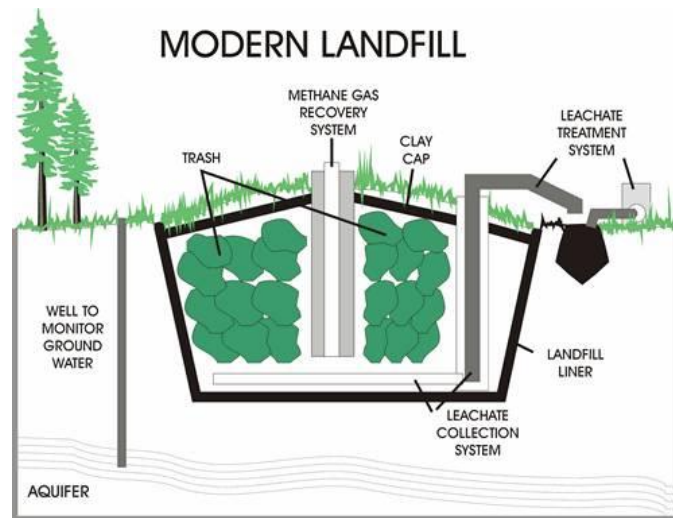

Source: Prometheus Energy (Undated)

13.4.2. POTENTIAL FOR ENERGY GENERATION FROM LANDFILLS

GLOBAL

There is significant potential for energy generation using LFG. Each year, 1.8 billion tonnes of waste is disposed of in Europe. In Greece, Portugal, the UK, Ireland, Finland, Italy and Spain, more than half of all waste ends up as landfill (EIONET 2009). Each year, the UK alone landfills 100 million tonnes of waste (ENER-G PLC 2007).

Urban populations in Latin America and Asia account for up to 78% of the population. Approximately 400 cities in developing countries have populations of 1 million or more. These populations tend to dispose of waste in local disposal sites, which are potential LFG sites (Peterson *et al.* 2008).

The Ministry of Non-Conventional Energy Sources in India has a national programme on energy recovery from urban, municipal and industrial wastes that has been operational since 1995. The estimated power generation potential from urban and municipal wastes in India is 1,000 MW (WEC 2000).

In Brazil, the National Research Centre for Basic Sanitation found that 228,413 tonnes of solid wastes is collected daily, of which 135,258 tonnes ends up in a landfill (PNSB 2000). This creates a significant potential for energy generation from landfill sites across the country.

Table 13-3 gives the population density of Brazil and its regional distribution. In addition, it also shows the amount of solid waste generated on daily basis by people and the regional distribution.

Table 13-3: Estimated solid waste generation in Brazil

	Total Population		Solid Wastes Generation (tonnes/day)		Per capita Generation (kg/hab/day)
	Value	%	Value	%	
Brazil	169,799,170	100	228.413	100	1,35
North	12,900,704	7,6	11.067	4,8	0.86
Northeast	47,741,711	28,1	41.558	18,2	0,87
Southeast	72,412,411	42,6	141.617	62	1,96
South	25,107,616	14,8	19.875	8,7	0,79
West-Center	11.636.728	6,9	14.297	6,3	1,23

Source: Coelho et al. (2006)

AFRICA

In African cities, where populations are growing rapidly, municipal waste will increase commensurately. Using urban waste for energy production mitigates the environmental impact of urban waste disposal while providing relatively clean energy in the form of methane for direct combustion (such as in heating and cooking) or electricity generation. But this potential energy source is not currently being tapped. Indeed, few urban municipalities in Africa are even aware of how much waste is being generated, collected, and disposed of.

Some assessments of energy generation potential from landfills have been carried out in Africa. Conakry, in Guinea, has a 20 year-old sanitary landfill, which was converted from an open dumpsite, and receives 90% of the waste generated in the city (ESMAP 2005). The waste in this landfill has 58% organic content. According to an assessment of the potential for energy generation by ESMAP, the Conakry landfill is an attractive candidate for generating energy to serve the residential areas surrounding the landfill site. The estimates show that 11 million cubic metres of LFG can be generated from the landfill, yielding about 5.37MW of installed electricity capacity (ESMAP 2005). Using estimates of waste generation based on urban populations, a rudimentary assessment of the amount of electricity that could be generated from landfilled waste in Africa is provided in Table 13-4.

Table 13-4: Estimates of LFG generation and electricity generation in Africa

Year	Africa Urban Population (Thousands)	Waste generated (000 tonnes) ^a	Waste landfilled (000 tonnes) ^b	Amount of LFG generation potential (000 cubic metres) ^c	Electricity generation Potential (000 MWh) ^d
1990	203,967	37,223,977	29,779,182	173,314,839	693,259
1995	247,524	45,173,130	36,138,504	210,326,093	841,304
2000	295,131	53,861,407	43,089,126	250,778,713	1,003,114
2005	349,392	63,764,040	51,011,232	296,885,370	1,187,541
2010	412,190	75,224,675	60,179,740	350,246,086	1,400,984
2015	484,434	88,409,205	70,727,364	411,633,258	1,646,533
2020	566,229	103,336,792	82,669,434	481,136,105	1,924,544
2025	657,833	120,054,522	96,043,618	558,973,856	2,235,895
2030	759,402	138,590,865	110,872,692	645,279,067	2,581,116
2035	869,392	158,664,040	126,931,232	738,739,770	2,954,959
2040	986,237	179,988,252	143,990,602	838,025,303	3,352,101
2045	1,108,407	202,284,277	161,827,422	941,835,596	3,767,342
2050	1,233,971	225,199,707	180,159,766	1,048,529,838	4,194,119

a) The estimates for waste generation are based on a ratio of 182.5kg per person per year, as estimated by ESMAP in an assessment of LFG potential in Dakar, Senegal.

b) An assumption is made here that 80% of the waste generated is landfilled, which is the average for waste landfilled in Conakry, Guinea (90%) and Dakar, Senegal (70%).

c) The amount of LFG generated from the landfill is estimated using a ratio of 1 tonne of landfilled waste yields 5.82m³ of LFG, based on data from Conakry, Guinea.

d) Electricity generation from the LFG is estimated using a ratio of 1 m³ generates 0.004MWh of electricity, based on data from ESMAPs assessments in Conakry, Guinea and Dakar, Senegal. This ratio assumes a low heating value of the methane gas and the combustion of the gas in an internal combustion engine with an overall efficiency of 33% electricity conversion and availability factor of 95%.

Source: UNFPA (2009), ESMAP (2005), USAID (2005)

13.4.3. STATUS OF ENERGY GENERATION FROM LANDFILLS

GLOBAL

Landfilling is one of the principal options for generating energy from waste around the world, and is widely practised in China in particular. There are also a significant number of CDM landfill initiatives in Asia and Latin America—see Box 13-1.

In recent years, landfilling has waned in popularity in Europe and is seen as the last resort when all other options have been exhausted (for example, re-use of the waste, recycling of the waste, etc.). The European Commission has issued a Landfill Directive, which aims "to prevent or reduce as far as possible negative effects on the environment, in particular the pollution of surface water, groundwater, soil and air, and on the global environment, including the greenhouse effect, as well as any resulting risk to human health, from the landfilling of waste, during the whole life-cycle of the landfill" (EC 2000).

In terms of innovation, Singapore has a unique offshore landfill facility created entirely from the sea space between two formerly adjacent islands. The landfill, the only one of its kind in the world to be

created entirely from sea space, receives 1,400 tonnes of incineration ash and 600 tonnes of non-incinerable waste daily. With a 63 million cubic metre capacity, it is expected to meet Singapore's need for landfill space beyond the year 2040. When the capacity is exhausted, an island made entirely of waste will be left behind. The Government of Singapore plans to build an eco-park on the closed landfill for demonstration of clean energy options (Waste Manager 2008).

A large number of LFG CDM projects have been implemented or are currently underway: registered CDM projects are shown in Table 13-5. The analysis of monitoring reports however shows that LFG projects often fail to deliver the forecast emission reductions, leading to the need for a closer analysis of whether the initial forecasts were over-estimated (Peterson *et al.* 2008).

Box 13-1: Landfill CDM projects in Asia and Latin America

1) **PHILIPPINES:** Montalban Landfill Methane Recovery and Power Generation Project

The objective of the project is to collect methane in LFG to generate clean electricity, by installing an onsite LFG collection system, power generation system and flaring system. The electricity generated will be distributed to the local grid system.

Expected Electricity Generation: Gas engines will be installed with an initial capacity of 15 MW. Electric transformers will be installed to convert the generated power to the correct voltage and amperage.

Benefits of the project:

- Energy generation: Methane is a clean fuel. The recovery of LFG and generation of power will contribute to the sustainable development of the Rodriguez Municipality.
- Flaring units: LFG not utilised for electricity generation will be fed into enclosed flares which have been designed to destroy LFG efficiently and at high temperature to ensure the maximum destruction efficiency and minimum noise pollution.
- LFG capture system: the landfill capture system is made up of a vertical piping system that are distributed across the area of the landfill. The system ensures that the maximum quantity of LFG is extracted from the system to ensure that the site is safe and the power generation system can operate efficiently

Source: UNFCCC (2006)

2) **MEXICO:** Aguascalientes EcoMethane LFG project was developed to address the LFG emissions from two local landfills, San Nicolas and Cumbres, and to generate about 2 MW of electricity for the grid.

Benefits of the project:

- The project at Aguascalientes provides for both short and long-term employment opportunities for local people
- The project has injected much needed capital into the local economy
- The project at Aguascalientes has helped Mexico fulfill its goals of promoting sustainable development by diversifying electricity generation sources, increasing jobs, using clean and efficient technologies, conserving natural resources, and acting as a demonstration project for improved landfill practices

Source: UNFCCC (2009)

Table 13-5: Registered LFG CDM projects with emission reductions performance reports and a comparison of reported to forecast emission reductions by year of project registration

Registration Year	Registered LFG projects	Registered LFG projects with monitoring reports	Forecast emission reduction from the PDD	Reported emissions reduction	Comparison of reported to forecast emission reductions (%)
2005	10	8	11,119,553	1,275,181	11.5
2006	25	20	20,646,628	8,436,336	40.9
2007	29	15	4,642,092	2,711,192	58.4
2008	24	6	817,768	310,170	37.9
Total	88	49	37,226,041	12,732,879	34.2

Source: Peterson et al. (2008)

AFRICA

LFG to energy projects are not widespread in Africa. Open dumps predominate in African cities, mainly as waste disposal sites with no capture of the LFG for energy generation. A review of experiences with LFG energy projects is provided in this sub-section.

In Dakar, Senegal, a large open, 25 year-old dump is used to dispose of the city's waste. The dump receives 77% of the waste generated in the city. There is no leachate treatment or recirculation practised. The waste is 50% organic, and based on assessments by ESMAP, about 18 million cubic metres of LFG can be generated from the waste. This would yield about 8.5 MW of electricity (ESMAP 2005).

A few CDM projects on LFG gas have been developed in Africa. In South Africa, the city of Durban launched Africa's first LFG to electricity project at the Mariannahill Landfill site. The project is currently operating at the Mariannahill and La Mercy landfills and is expected to be extended to the larger Bisasar Road landfill. The project will convert LFG to electricity and generate revenues through the sale of electricity and CERs. The installed capacity of the project is 10MW (ESMAP, 2005). It is worth noting that, at the time of conception, the Durban project was not economically attractive without the carbon finance aspect, due to the low electricity prices in South Africa. However, electricity prices are increasing in South Africa, and it would be useful to track the performance of this project over time.

In Egypt, a proposed LFG project will serve 4 districts in Greater Cairo with an annual capacity of 400,000 tonnes/year of municipal solid waste. The project is to be carried out by the Egyptian government and an international company for the collection and final disposal of solid waste. The project is expected to reduce approximately 620 million m³ of methane gas, and other GHG emissions in the area.

In Tanzania, a LFG to energy CDM Project is currently operational in Mtoni, 10 km from Dar es Salaam city centre. The project covers 8.5 hectares of land and is owned and operated by the Dar es Salaam City Council in partnership with Consorzio Stabile Globu of Milan Italy. The project aims to capture about 65% of the biogas produced at the dumpsite, estimated to equivalent to approximately 200,000 CERs per year, and use it to generate about 3.5 MW of electricity. At a cost of 10-12 Euros per carbon credit, the project will be able to generate extra revenue in the region of €2-2.4 million in addition to the revenue from electricity sales. The total investment cost for the project was about 4,000,000 Euros and the return on investment is estimated to be about 2 years (if only considering carbon credit sales) (Mero and Ndongsok 2008).

13.5. KEY DRIVERS AND BARRIERS

Two of the key drivers for development of LFG to energy projects are economic and environmental.

13.5.1. ECONOMIC DRIVERS

Until recently, rapid increases in oil prices have been an important rationale for promoting LFG as an alternative energy source for household and institutional lighting, cooking and electricity. For instance, the recent increase in oil prices, which peaked at above US\$150 per barrel, occurred at a time when Sub-Saharan Africa's capacity to generate electricity from hydropower was adversely affected by recurrent droughts, as a result of which many countries in the region resorted to costly thermal power production as an emergency back-up measure. LFG can provide an important lower cost alternative to diesel-generated power.

LFG energy projects have high potential for generating local jobs. Estimates show that LFG energy projects generate 2.28 jobs/MW, in the operation and maintenance of the plant (Lehmer, 2008). The collection and delivery of wastes has the potential to create additional jobs for a large portion of Africa's low-income urban population. Landfill sites can create employment in the registration and weighing of waste and collection of tipping fees,⁴¹ as well as the sale of electricity.

Table 13-6 presents estimates of job creation using different renewable energy sources which shows the higher job creation potential of the landfill waste-to-energy option.

Table 13-6: Job creation potential for renewables

Energy Technology	Average Employment Over Life of Facility (Jobs/MW _a) for Operation & Maintenance and fuel processing
Solar PV	1.20
Wind	0.27
Biomass	2.44
Coal	0.74
Gas	0.70

Source: Kammen et al. (2004)

13.5.2. ENVIRONMENTAL DRIVERS

Use of the gas produced by landfills can reduce the harmful environmental impacts that would otherwise result from landfill operations, if left unchecked: these include unpleasant odours and uncontrolled fires due to spontaneous combustion of seeping gas and waste water/ leachate. LFG electricity generation offers major air quality benefits, where landfills already exist or where the decision to build the landfill has already been made. In addition, LFG can play a key role in reducing greenhouse emissions by replacing fossil fuels such as kerosene and mitigating greenhouse

⁴¹ Tipping fees can provide municipalities with revenue and promote the landfill 'business model'. But they can also dissuade people from sending their rubbish to the landfill in the first place (promoting illegal dumping or other, legitimate ways of waste disposal such as composting). Indeed, in the developed world, tipping fees are designed to provide an incentive not to landfill waste.

emissions from waste dumps, thus attracting carbon financing for further development of the technology (ETC 2007; FAO 2007).

Some of the key barriers to the development of land\fill gas technology are discussed below.

13.5.3. HIGH IMPLEMENTATION COSTS

Plant costs for LFG vary from country to country, depending amongst other considerations on the economic context, the design of the plant, and whether the technology was imported. To date, only a few studies have attempted to compare the technological costs.

Using data from a World Bank-financed project, the investment and project costs for LFG energy projects were estimated in an ESMAP (2005) study. The investment costs for the design and construction of the LFG energy projects were determined through a proxy method, using data from the Methane Gas Capture and Use Facility at SIMEPRODESO in Mexico, a Global Environment Facility (GEF) project, and EPA guidelines for preliminary site assessment. The costs of implementing LFG are as presented in Table 13-7.

Table 13-7: Investment costs for methane gas capture and use in Conakry and Dakar

Country	Mexico	Conakry	Dakar
Installed capacity (MW)	7.0	5.4	8.5
Gas recovery costs (US\$)			
Gas recovery equipment	1,946,160	1,501,323	2,363,194
Gas cleaning equipment	54,000	41,657	65,571
Gas use costs (US\$)			
Complete system for electricity generation			
Engine house	43,200	33,326	52,457
Engines	6,456,024	4,980,361	7,839,458
Electrical substation (34.5 kilovolts)	828,360	639,021	1,005,866
Interconnection line	432,000	0	0
Contingencies (10% physical; 7% price)	1,665,582	1,223,267	1,925,513
Sub-total	11,425,326	8,418,955	13,252,059
Other costs (US\$)			
System design cost		1,262,843	1,987,809
Training	37,800	100,000	100,000
Total investment costs (US\$)	11,463,126	9,781,798	15,339,868
Cost per MW installed (US\$)	1.64 million	1.81 million	1.80 million

Source: Ouedraogo (2005)

In addition, Table 13-8 shows the investment cost per MW generated from various renewable energy sources.

Table 13-8: Energy generation costs from various renewable energy sources

Renewable Energy Source	Typical installed Cost (\$/kW)
Hydro Turbine	\$550 to \$4,500
LFG	\$1,640 to \$1,800
Geothermal System	\$1,800 to \$2,000
Wind Turbine	\$1,000 to \$3,000
Photovoltaic Module	\$8,000 to \$12,000

Source: Retcreen (2005), IEA (2008)

13.5.4. AVAILABILITY OF LAND IN URBAN AREAS

Land in urban areas of Africa and other developed parts of the world is quickly becoming a scarce commodity. The rapid rate of urbanization taking place in most areas of the developing world puts tremendous pressure on the land resource (AFREPREN/FWD 2008).

13.5.5. DECENTRALIZED COLLECTION OF BIO-DEGRADABLE WASTE

In many urban areas of the world, especially in developing countries, there is no organized system of USM collection and management. Due to this, waste is normally scattered around the urban area, making it difficult for organizations that want to invest in LFG technology to centralize the waste storage in a landfill. In addition, in Africa and many parts of the developing world, USW is normally not separated at source: kitchen waste, plastics, bottles and other wastes are normally disposed of together. This makes it more challenging still to obtain the appropriate waste matter required for the feedstock for LFG. A non-functional urban waste system is a major barrier to landfill waste to energy investments, as demonstrated by the following case study of Tanzania (Box 13-2).

Box 13-2: Case Study: Tanzania landfill gas project

The Tanzanian Ministry of Water, Energy and Minerals carried out a comprehensive study of the digestion of Urban Solid Waste (USW) to produce biogas in Tanzania in 1993. The study showed that there is a large potential for biogas production in Tanzania, some of which can be used to generate electricity.

Based on the study, a project dubbed 'TAKAGAS' was proposed. The development objective of the project was to mitigate methane and carbon dioxide emitted by USW as a result of uncontrolled aerobic and anaerobic digestion of USW. The project planned to use methane gas produced to generate electricity for export to the national grid, thereby displacing fossil fuels (mainly diesel) hitherto used for electricity generation.

In addition to electricity generation from about 50 tonnes of waste per day, the plant was also expected to provide biogas as a fuel for its trucks as well as produce a fertilizer as a by-product from the slurry. Table 13-9 provides the expected production of biogas and electricity from the plant.

Table 13-9: Output from the digestion of waste in Dar es Salaam

Product	Quantity
Solid residue	30 tonnes/day
Liquid residue	20 tonnes/day
Gas produced	6,400 m ³ of biogas/day
	4,200 m ³ of CH ₄ /day
Energy content	(35.9 MJ/m ³ CH ₄): 150 GJ/day or 41 MWh/day
Truck fuel	200 m ³ of CH ₄ /day
Available for gas engines	4,000 m ³ of CH ₄ /day: 39 MWh/day
Electricity output, x 0.3	11.8 MWh/day
Internal use output electricity	1.9 MWh/day
Electricity sold to public grid	9.9 MWh/day

Source: Ministry of Water, Energy and Minerals (1993)

The project consisted of multilateral financing from UNDP/GEF and DANIDA. The Tanzanian Government provided in-kind contributions (Mwihava 2004; ESMAP 2005). The foreign co-financing was expected to meet the cost of capital investment. The cost allocation budget breakdown for the project is provided in

Table 13-10.

Table 13-10: Cost estimates for the "TAKAGAS" project

Item	Cost (US\$ '000)
Construction	2,010
Design, Construction and Project Management	425
Transport and gas handling	722
Laboratory facilities	24
Training	610
Contingencies	200
Total	3,991

Source: Ministry of Water, Energy and Minerals (1993)

Once commissioned, the project was expected to be financially self-sufficient through the sale of the plant's three main products (electricity, fuel and fertilizer). Operating revenue was expected to provide a stream of resources required to promote and replicate biogas technology throughout the country, as well as for recurrent plant operations and maintenance. The operating cost figure included an allocation for two years for an experienced biogas plant specialist to be employed. From the third year onwards, the annual operating costs were expected to reduce. The expected annual profits were expected to average approximately US\$300,000 (GEF 1993). This would have given a payback period of about 13 years on the financial investment, with the remaining 12 years of the plant's lifetime being the investor's profit. Table 13-11 shows a summary of the financial projections.

Unfortunately, even before the plant's construction began, the project was terminated. Some of the reasons for terminating the project included: inadequacy of the pre-investment study; delay in the project's land acquisition; absence of a solid waste delivery system; inadequate enforcement of waste management legislation; and inability to raise additional funds (ESMAP 2005). These issues provide useful lessons for future LFG energy projects in developing countries.

Table 13-11: TAKAGAS project economics after commissioning

Item	(US\$ 000)
Operating Costs Per annum	
Salaries	\$29
Operation of Transportation Equipment	\$60
Maintenance of Plant	\$60
Miscellaneous	\$20
Total	\$169
Income per annum	
Sale of Electricity (9,900 kWh x 0.1 US\$ x 365)	\$361
Gate Fee for Wastes (13,500 tons/year, US\$ 1.2/ton)	\$16
Revenue from Removal of Industrial Waste (7,300 tons/year, US\$ 5/ton)	\$37
Total	\$414

Source: Ministry of Water, Energy and Minerals (1993)

13.6. POLICY AND INSTITUTIONAL FRAMEWORK FOR LANDFILL ENERGY

13.6.1. POLICY AND INSTITUTIONAL ISSUES

Although a number of countries around the world are in the process of formulating biofuel strategy documents, it still remains unclear whether landfill or LFG technology will be one of the key options to be promoted. For example, in Kenya, the Energy Act 2006 has provisions for promotion of renewable energy, which includes LFG. However, the necessary legal and regulatory framework for the promotion and adoption of landfill and LFG still needs to be put in place (Government of Kenya 2005). Box 13-3 summarizes guidelines for the landfilling of waste developed in South Africa.

Box 13-3: South African minimum requirements for landfilling of waste*

The Minimum Requirements classify landfills according to:

- **Waste types:** General waste (primarily non-hazardous solid wastes); or hazardous waste (HZW) (rating according to degree of hazard);
- **Size of waste stream:** Communal sites (1-25 tonnes per day), Small (25-150 tonnes per day), Medium (150-500 tonnes per day) and Large (>500 tonnes per day);
- **Climatic water balance:** Significant leachate generation (in wet areas, where leachate collection and treatment is required) and no significant leachate generation (in arid and semi-arid areas where leachate collection is not required).

Source: Johannessen and Boyer (1999)

*Stringency increases with hazardness of waste, size of the landfill, and possible leachate generation.

LFG energy projects require the coordination of a large number of actors, from both the public and private sectors, whose efforts must be streamlined and synchronised. The absence of a supportive and well-coordinated institutional framework can lead to the failure of LFG to energy projects (Amigun *et al.* 2007). A brief review of the actors necessary for a successful LFG energy project delivery in four selected countries is provided in Table 13-12.

Table 13-12: Key actors in urban waste sub-sector

Country: City	Key Actors in Urban Waste Sub-Sector
Cote d'Ivoire: Abidjan	<ul style="list-style-type: none"> • The Ministry of Environment – responsible for policies on public health and managed the contract between ASH International (the private company responsible for waste collection and disposal) and trained pre-collectors • The Ministry of Interior – supervised local governments • The Ministry of Economy and Finance – met the city's financial obligations • Department of Major Public Works – offered technical support to the Ministry of Environment in monitoring ASH International agreements • The City of Abidjan – offered weighing and monitoring services • Pre-collectors • Scavengers and recyclers – not organised into a particular association and not officially recognized

Guinea: Conakry	<ul style="list-style-type: none"> • In Conakry, the key actors in waste management are mainly the Government (also the key decision-maker), the municipalities, and the private sector and SMEs involved in street cleaning in the five municipalities of Conakry and the waste collection from households. Through an urban waste project, the World Bank is involved in the establishment of legal and institutional mechanisms to facilitate SMEs' access to credit from local banks.
Senegal: Dakar	<ul style="list-style-type: none"> • Municipality and private operators provide collection services on a fee basis to households and commercial establishments. Collection is carried out by human- and animal-drawn carts (wheelbarrows, pushcarts), open-back trucks, compactor trucks, and trailers. Collections from market places and commercial centers tend to be made in the evening and collections from residential areas and of street sweepings are made at dawn. • The responsibility for waste management lies with local authorities through the Communauté Urbaine de Dakar (Dakar Urban Community). • The Senegalese government recently signed an agreement with Alycon, a Swiss company whose main responsibility is to collect and manage waste and keep the streets of Dakar clean. The contract was signed on January 5, 2000, and is expected to end on December 31, 2026.
India	<ul style="list-style-type: none"> • There are a number of government actors who will likely play a role in India's LFG to Energy development, including local municipalities and the Ministries for Environment and Forests, New and Renewable Energy and Urban Development. In India, local municipalities have the overall responsibility for MSW management. They implement laws created by the Ministry for Environment and Forests. • Ministry for Environment and Forests <ul style="list-style-type: none"> ○ The Ministry created the Municipal SolidWaste Management and Handling Rules 2000. It governs the Central Pollution Control Board, which is responsible for the oversight of the 2000 Rules. • Ministry of New and Renewable Energy <ul style="list-style-type: none"> ○ This Ministry covers both renewable energy and new fossil fuel technologies. The Ministry is leading the project on Development of High Rate Biomethanisation Processes, which is being implemented and partially funded by the United Nations Development Programme (UNEP) and the Global Environment Facility (GEF). The Ministry has recently indicated that it is willing to consider making subsidies available to LFGE projects. • Ministry of Urban Development <ul style="list-style-type: none"> ○ This ministry is a nodal Ministry overseeing urban development in India. The Ministry's Central Public Health and Environment Engineering Organisation (CPHEEO) guides the states and municipalities on technical aspects of solid waste management. As such, CPHEEO is conducting data collection on methane extraction potential from landfills in the country.

Source: ESMAP (2005), Karekezi et al. (2004), IEA (2008)

Many developing country city dwellers lack environmentally-sound waste collection or access to disposal services, except in the wealthier neighbourhoods or communities. Waste disposal and management is normally decentralised and with no clear guidelines, policy or legislation governing the waste management (USAID 2005). This often leads to the mismanagement of the sub-sector, leading to the wastage of otherwise “potentially good waste” that can be used in landfill sites for the generation of LFG. As demonstrated in the case of TAKAGAS in Tanzania, without enforceable legislation on waste collection and management in place, the conversion of waste to energy cannot compete with conventional technologies. Careful consideration of the city, climate and culture is essential to achieving universal collection at recommended frequencies (USAID, 2006).

13.6.2. ACCESS TO LAND

Procedures for land allocation have to be followed when considering a LFG project. Strong political support for landfill projects can lead to prioritization of land for such projects, when the benefits are well articulated to stakeholders and the public.

In the case of the TAKAGAS project in Tanzania, although the Government was fully committed to the project, the political will was not adequately translated into action. During the period 1994 to 1996, Dar es Salaam City Council (DCC) had some administrative problems, which to a great extent contributed to the delays. As a result, some of the council committee meetings were not held on time to deliberate on the TAKAGAS project plot. The Prime Minister in 1996 intervened, though it was rather late for the plot acquisition process, as the project was being wound down.

The issue of land is therefore crucial and must be included in policy documents on LFG projects.

13.7. FINANCING ISSUES FOR LANDFILL

13.7.1. LIMITED FINANCING OPTIONS

Landfill and the production of LFG is often a high up-front cost venture that may require government support in the initial start-up phases. There are limited financing options for LFG-to-energy projects. Those that do exist include: municipal funds, taxes and levies, and international donor funds such as the World Bank and GEF (USAID 2005). Traditional banks in the region are generally unwilling to provide finance due to market uncertainties and perceived high risks of the technology.

As demonstrated in the TAKAGAS Project in Dar es Salaam, Tanzania, the failure to raise additional funds for the project by the donors and the Government of Tanzania demonstrated an unwillingness to invest in LFG energy projects. Both project financiers were not sure if the envisaged plant would ever achieve the original objectives, which included the ability to sustain itself (ESMAP 2005; Mwiha 2004).

13.7.2. INADEQUATE PRE-FEASIBILITY AND FULL-FEASIBILITY STUDIES

The assessment of project feasibility is another key issue in the financing of an LFG energy project. Accurate estimates and data are required to estimate the potential energy output and revenue flows, which are included in pre-feasibility and full-feasibility studies. For LFG energy projects, a large number of factors affect the actual operation of the plant and must be carefully assessed in the pre-

feasibility and feasibility stages. The experience in the CDM, for example, is that in many instances the reported biogas volumes are lower than the forecast amounts (Peterson *et al.* 2008).⁴² An accurate estimation of the energy generation potential in the pre-feasibility assessment is essential to the success of the project, but may cost as much as US\$50,000 (Biomethane Technologies 2009).

In the case of the Takagas project, the pre-feasibility study was later found to be inadequate and inaccurate, and the projected revenue streams of US\$300,000 proved not to be realistic (Mwihava 2004).

13.7.3. ABSENCE OF PRE-DETERMINED TARIFFS AVAILABLE FOR LANDFILL GAS PROJECTS

A standard price offer would eliminate investment uncertainties associated with renewable energy investments such as LFG. Experience in other countries indicates that a significant amount of investment in renewables occurs once a standard price is announced. The case of the TAKAGAS and Durban landfills, for example, demonstrates the need to carefully assess the price of the power generated from the landfill, since in both cases the price was often higher than the existing tariffs. In the case of Durban, the project proved viable only after the inclusion of sale of carbon credits (ESMAP 2005).

13.7.4. LENGTHY AND COMPLEX PPA NEGOTIATIONS

The electricity generated from LFG energy projects is often targeted for sale to the grid, and a power purchase agreement with an attractive price should be in place prior to implementation of the project. Power Purchase Agreement (PPA) negotiations can take many years before they are awarded. In addition, they can be expensive as they may involve several types of experts (technical, legal and financial) to assist in the negotiations.

As with other renewable energy projects that generate electricity for sale to the grid, LFG projects require measures to simplify the bureaucratic approach associated with PPAs. A standard PPA customised for LFG would be useful and would facilitate local participation in the industry. While there is often a generic standard PPA issued by the energy regulator, it is usually not specific enough to provide sufficient and strong incentives for LFG technology development.⁴³ Having a standard offer could eliminate uncertainties associated with LFG investments.

⁴² A UNEP Risoe Centre analysis shows that the performance of LFG projects relative to initial developer expectations is only 39%, placing them as one of the worst-performing project-types in the CDM pipeline. This suggests that the notion of LFG projects as low-hanging fruit for CDM finance needs to be revisited (CDM Investment Newsletter, 2008).

⁴³ In order for LFG gas to get the kind of promotion and investments needed to make it a sustainable technology, there is need for a specific and target-oriented PPA for LFG. For instance, there is a standard PPA in Kenya for the promotion of renewables, but it only explicitly mentions wind, small hydro power and cogeneration and does not mention LFG. This may serve inadvertently to limit the promotion of the technology because the other explicitly mentioned technologies will attract most of the financing and development.

13.8. TECHNICAL CAPACITY ISSUES FOR LANDFILL

13.8.1. LACK OF EXPERIENCED PROJECT DEVELOPMENT PERSONNEL

Expertise on management and operation of LFG energy plants is not widely available in developing countries. This is mainly due to the small number of operational plants in developing countries (with the exception of China, with a large number of installations and expertise). Expertise must generally be sought from abroad: for example, in the TAKAGAS project, experts from Denmark were expected to work with the local project participants in the first two years to train and provide skills on operation of LFG to energy projects.

13.8.2. ABSENCE OF RELIABLE FEEDSTOCK DELIVERY MECHANISM TO THE PLANT

Availability of feedstock on a sustainable basis is crucial to the success of LFG energy projects. Landfills require about 2 million tonnes of existing wastes, and an ongoing daily intake of 150 tonnes of waste (USAID 1988). Therefore, well-defined delivery arrangements (including costs) are critical for LFG energy projects.

In the case of the Takagas plant, the key assumption on the feedstock was that waste would be sorted out at the point of generation or collection. This habit is not widely practised in most households, hotels and market places. Some potential providers of specialized waste, such as breweries, abattoirs and oil processing industries, indicated that, since some or all of their waste was used by other customers, they would deliver the waste at a cost (Mwihava 2004). In addition, the waste material had to be transported to the dump site and the private solid waste collection contractors demanded payment for this service. With the exception of the market and hotel waste, which could be delivered by the City Commission Council and the Red Cross, the assumptions made by the pre-feasibility study on mechanisms for delivery of waste proved inaccurate, and changed the economics of the project.

If outstanding scientific and pilot testing questions are resolved, conversion of existing open dumps, as practiced in Brazil Box 13-4, could address the issue of building up waste in LFG energy projects.

Box 13-4: Bio-remediation landfills in Brazil

In the Brazilian context, bio-remediation means 'to excavate an old dump', to mix the excavated old waste with fresh refuse in a 70:30 waste/water ratio, to treat the generated leachate in a biochemical-physical process, to add an engineered microorganism, to re-circulate the leachate back into the landfilled waste, and to let leachate levels build up inside the landfilled waste body.

Part of this process (engineered microorganisms are not added) is currently being applied at one landfill - the remediated part of the old Caxias do Sul landfill in the Caxias do Sul municipality of Rio Grande do Sul State. Analyses of the leachate analyses show clear indications of strict methanogenic conditions in the waste and thus a high degree of bio-degradation. But it is still unclear whether a high level of microorganisms under bio-degradation in old waste will additionally enhance the biodegradation process in the new waste.

Over a four-year period, the Americana landfill re-disposed of 10-year-old waste mixed with fresh refuse, leachate treatment, and recycling of microorganism-enriched leachate. The leachate treatment process was discontinued in 1991 due to lack of funds for landfill operation.

Source: USAID (2005)

13.9. RECOMMENDATIONS

Governments around the world need to enact policies that are supportive of LFG technologies, if the technology is to be commercially adopted by the private sector. In addition, due to the uncoordinated nature of urban waste collection and management systems in most parts of the developing world, there is an urgent need for the development of policies and regulations that are aimed at governing and streamlining the management and collection of urban waste.

Due to the large number of open dumps in Africa, the emphasis in Africa should be to enact legislation for converting open dumps into sanitary landfills, and capturing the gas for energy generation. This would not require new land and should be relatively easy to implement.

In addition, financial analysis of LFG projects should be undertaken to steer project developers to the most attractive investment opportunities. A parallel effort should be directed towards mobilizing financing for landfill technology assessments and project implementation.

Some of the proposed ways of addressing this challenge would be efforts aimed at accessing financial subsidies for meeting the upfront cost of technology through financing mechanisms such as the CDM. In countries with low electricity tariffs, CDM financing for LFG energy projects is recommended (ESMAP 2005). Other aspects that would improve the financial and operational attractiveness of landfill technology include:

- Attractive revenue-sharing schemes, where all involved in the collection and management of waste have clear incentives, similar to the system implemented for bagasse cogeneration in the sugar industry of Mauritius.
- Introduction of fiscal incentives such as tax holidays and waivers on import duty on imported components for the construction of LFG to energy plants.

To further enhance LFG technology around the world, governments need to issue a standard price offer as well as implement a standard PPA for the generation of LFG. This will not only make it lucrative for local investors but also ensure a level playing field among energy sector investors.

Training is required in accurate pre-investment analysis for LFG to energy projects. The training should be based on successful projects which have delivered over the years, such as the landfill waste to energy projects in Latin America and Asia.

In addition, cooperation in designing and establishing landfill programmes, between countries in the region as well as countries from other regions with similar ecosystems/climatic conditions, can deliver significant benefits. Activities should be geared towards establishing long-term training programmes on landfilling at local and regional level. In addition, exchange of skills and experiences between countries with limited expertise and countries with more developed technical capacity on landfill technologies should be enhanced.

Finally, a number of pilot and demonstration projects should be implemented to provide flagship initiatives that can stimulate the expansion of the landfill industry.

13.10. REFERENCES

- AFREPREN/FWD (2008) *Evaluating Anaerobic Digesters Energy Generation Opportunities and Barriers in Africa*, Nairobi, Energy Environment and Development Network for Africa (AFREPREN/FWD)
- BUN (1991) *Energy Recovery from Urban and Rural Solid Wastes in Egypt*. *Biomass Users Network News*. San Jose, Costa Rica: Biomass Users Network (BUN). pp. 1-3.

- Cointreau S.J. (1984) Environmental management of urban solid waste in developing countries: a project guide, *World Bank Urban Development Technical Paper 5*, Washington DC: The World Bank
- European Commission (2003) www.jrc.es/projectsintersudment/algeria. Brussels: European Commission
- Faaij, A. (1997) *Energy from Biomass and Waste*. Netherlands: Utrecht University
- Goodman, B.J. and Walter, D.K. (1991) Opportunities for Energy from Municipal Waste Technology. *Energy Sources Journal*, Volume 13: 179-188.
- Haskoning, B.V. and Konsult, M. (1989) *Staged Action Plan on Pollution Management for Dar es Salaam*. Dar es Salaam, Tanzania: Ministry of Water Department.
- IEA. (2008) *Turning a Liability into an Asset: Landfill Methane Utilisation Potential in India*. Paris: International Energy Agency (IEA).
- IETC (1996) *International Source Book on Environmentally Sound Technologies for Municipal Solid Waste Management*. Technical Publication Series, Issue 6. Japan: International Environmental Technology Centre (IETC).
- IPCC (1996) *Technologies, Policies and Measures for Mitigating Climate Change*. Geneva, Switzerland: Intergovernmental Panel on Climate Change (IPCC).
- Johannessen, L.M. and Boyer, G. (1999) *Observation of Solid Waste Landfills in Developing Countries*. Washington, D.C., The World Bank.
- Kammen, D., Kapadia, K., Fripp, M. (2004) *Putting Renewables to Work: How Many Jobs Can the Clean Energy Industry Generate?* RAEI Report, University of California, Berkeley.
- Mero, R. and Ndongsok, D. (2008) *Clean Development Mechanism as a Tool for Sustainable Development: Case Study of Tanzania*. First Climate, presentation at the Geneva Trade and Development Forum.
- Mwihava, N.C.X. (2004) *A Solid Waste / Greenhouse Gas Management Project That Did Not Take Off*. Dar es Salaam, Tanzania: Ministry of Energy and Minerals
- NUTEK (1997) *IEA Bio-energy: Annual Report 1996*. Stockholm, Sweden: Swedish National Board for Industrial and Technical Development (NUTEK)
- Open University (1994) *T521 Renewable Energy: A Resource Pack for Tertiary Education*. Milton Keynes, UK: The Open University
- Pearce, D. (1993) *Blueprint 3: Measuring Sustainable Development*. London: Earthscan Publications Limited
- Peterson, C., Bowden, N., and Bhaskar, A. (2008) *Landfill Gas Recovery System Performance*. Washington DC: The World Bank.
- Prometheus Energy (undated) Modern Landfill. Website (accessed 27th July, 2009): www.prometheus-energy.com/image/landfillgas_clip_image004.png
- Retscreen (2005) *Combined Heat and Power Project Analysis*. Ottawa: Natural Resources Canada. Website (accessed 20 July 2009): www.retscreen.net/...php/.../RETSscreen4_overview_CHP.ppt
- State of the World (2007) *Into a Warming World: The Coming Century of Climate Change and How to Manage and Survive It*. World Watch Institute, Washington DC
- UNFCCC (2006) *Ecatepec—EcoMethane Landfill Gas to Energy Project*. Website (accessed on 27th July 2009): <http://cdm.unfccc.int/UserManagement/FileStorage/3WEX136BA57MKV0WQDR0AR1JJYPO0C>
- UNFCCC (2009) Montalban Landfill Methane Recovery and Power Generation Project. Website (Accessed 27 July 2009): <http://cdm.unfccc.int/UserManagement/FileStorage/27401SFWYM3R65LTZDXJ89CGIEVKQU>
- USAID (1988) *Prospects in Developing Countries for Energy from Urban Solid Waste*. Bio-energy Systems Report, Office of Energy. Washington DC: USAID.
- USAID. (2005) *USAID and Sustainable Tourism: Meeting Development Objectives*. Washington DC: USAID.
- World Resources Institute (1992) *World Resources 1992-1993: A Guide to the Global Environment*, New York and Oxford: Oxford University Press.
- World Resources Institute (1998) *World Resources 1998-99: A Guide to the Global Environment*, Oxford: Oxford University Press.

14. GLOSSARY

Adaptation: adjustment in natural or human systems to a new or changing environment. Adaptation to climate change refers to adjustment in natural or human systems in response to actual or expected climatic stimuli or their effects, which moderates harm or exploits beneficial opportunities. Various types of adaptation can be distinguished, including anticipatory and reactive adaptation, private and public adaptation, and autonomous and planned adaptation.

Afforestation/Reforestation: since the definitions of afforestation and reforestation differ only in the period of time that project land has existed without forest cover, they are treated similarly in the CDM. Afforestation is the conversion into forested land of land that has never contained forest or, at least, has not contained forest for a significant amount of time (at least 50 years for the CDM). Reforestation is the conversion of land that was, at some point, forested in the more recent past, often indicated by a specific deadline, into forested-land. For the CDM, the deadline is 31 December 1989.

AFOLU (Agriculture, Forestry and Other Land Uses): more holistic emissions accounting framework to integrate agriculture along with land-use, land-use change and forestry (LULUCF). Guidelines for AFOLU in the 2006 IPCC Guidelines for National Greenhouse Gas Inventories provide the current standard for terrestrial GHG accounting. In addition to sectors under LULUCF, the AFOLU emissions accounting framework includes in the agriculture sector: liming and urea application, N₂O emissions from soils (direct/indirect), emissions from biomass burning, enteric fermentation, manure management and rice cultivation.

Baseline: the baseline (or reference) is any scenario against which change is measured and is defined in the CDM as “that [which] would have occurred in the absence of the registered CDM project activity”. CDM project developers need to select a baseline approach represents observable, present-day conditions. An alternative approach is to select a “moving” baseline, which is a projected future scenario (excluding carbon finance) based on anticipated trends. Depending on the baseline approach adopted, a baseline may be assumed to remain the same over the crediting period (whereby monitoring of baseline conditions is not required) or is expected to change, which requires monitoring over the crediting period. As a hypothetical situation of what would have happened in the absence of bio-carbon project, the baseline is a counterfactual.

Biomass: total dry weight of all living organisms that can be supported at each trophic level in a food chain. Also, materials that are biological in origin, including organic material (both living and dead) from above and below ground: for example, trees, crops, grasses, tree litter, roots, and animals and animal waste.

Bio-carbon: the broad sector, including renewable energy derived from biomass and organic wastes as well as the carbon sinks (trees, vegetation, soil and peat) found in agricultural, forest and other terrestrial ecosystems.

Bio-energy: energy derived from biomass (itself part of complex ecosystems) to be used for heat, electricity, or vehicle fuel. Bio-energy can be renewable or non-renewable, depending on the balance between harvesting and growth of the biomass feedstock concerned.

Bio-char: charcoal-like substance resulting from low-temperature pyrolysis of biomass. It has a two-fold higher carbon content than ordinary biomass and locks up carbon in a much more durable form than biomass. Bio-char could, in theory, be deposited in soils to store carbon for hundreds or perhaps thousands of years.

Capacity Building: increasing skilled personnel and technical and institutional abilities.

Carbon Dioxide Fertilization: the enhancement of the growth of plants as a result of increased atmospheric CO₂ concentration.

Climate Change: climate change refers to a change in the state of the climate that can be identified (e.g. using statistical tests) by changes in the mean and/ or the variability of its properties, and that persists for an extended period, typically decades or longer. Climate change may be due to natural internal processes or external forcings, or to persistent anthropogenic changes in the composition of the atmosphere or in land use. The UNFCCC, in its Article 1, defines “climate change” as “a change of climate which is attributed directly or indirectly to human activity that alters the composition of the global atmosphere and which is in addition to natural climate variability observed over comparable time periods”. The UNFCCC thus makes a distinction between “climate change” attributable to human activities altering the atmospheric composition, and “climate variability” attributable to natural causes.

CO₂e (Carbon Dioxide Equivalent): a measure used to compare the emissions from various greenhouse gases based upon their global warming potential (GWP). The carbon dioxide equivalent for a gas is derived by multiplying the mass of the gas by the associated GWP.

Conference of Parties (COP): the supreme body of the UNFCCC.

Deforestation: those practices or processes that result in the conversion of forested lands to non-forest uses. This is often cited as one of the major causes of the greenhouse effect for two reasons: 1) the burning or decomposition of the wood releases carbon dioxide; and 2) trees that once removed carbon dioxide from the atmosphere in the process of photosynthesis are no longer present.

Emissions: in the climate change context, emissions refer to the release of GHG and/or their precursors and aerosols into the atmosphere over a specified area and period of time.

Emissions Factor: a unique value for scaling emissions to activity data in terms of a standard rate of emissions per unit of activity (e.g. grams of carbon dioxide emitted per barrel of fossil fuel consumed).

Feedback Mechanism: factors which increase or amplify (positive feedback) or decrease (negative feedback) the rate of a process. An example of positive climatic feedback is the ice-albedo feedback.

Gasification: gasification is a thermo-chemical process in which feedstocks such as coal, petro-coke or biomass are converted into a gas consisting of hydrogen and carbon monoxide under oxygen depleted, high pressure, high-heat or steam conditions.

Global Warming Potential (GWP): defined as the cumulative radiative forcing effects of a gas over a specified time horizon resulting from the emission of a unit mass of gas relative to CO₂ and expressed in terms of carbon dioxide equivalents (CO₂e). GWP of common GHGs associated with bio-carbon are: CO₂ = 1, CH₄ = 21, N₂O = 310. GWP for industrial gases are considerably higher.

Greenhouse Gas (GHG): a gas that absorbs radiation at specific wavelengths within the spectrum of radiation (infrared radiation) emitted by the Earth’s surface and by clouds. The gas in turn emits infrared radiation from a level where the temperature is colder than the surface. The net effect is a local trapping of part of the absorbed energy and a tendency to warm the planetary surface. Water vapour (H₂O), carbon dioxide (CO₂), nitrous oxide (N₂O), methane (CH₄) and ozone (O₃) are the primary GHG in the Earth’s atmosphere.

IPCC (Intergovernmental Panel on Climate Change): established in 1988 by the World Meteorological Organization and the UN Environment Programme, the IPCC surveys world-wide scientific and technical literature and publishes assessment reports that are widely recognized as the most credible existing sources of information on climate change. The IPCC also works on

methodologies and responds to specific requests from the Convention's subsidiary bodies. The IPCC is independent of the Convention.

Kyoto Protocol: a protocol to the UNFCCC that establishes legally binding commitments for the reduction of GHGs produced by "Annex I" (industrialized) nations. As of January 2009, 183 parties have ratified the protocol, which was initially adopted for use on 11 December 1997 in Kyoto, Japan, and which entered into force on 16 February 2005. Under the Kyoto Protocol, industrialized countries have agreed to reduce, by 2012, their collective greenhouse gas emissions by 5.2% relative to 1990 levels.

LULUCF (Land-use, Land-Use Change and Forestry): emissions and removals of GHGs resulting from direct human-induced land use, land-use change and forestry. Associated with the IPCC accounting framework which considers emissions and removals resulting from changes to forested land, grassland, cropland, settlements, wetlands, other land and harvested wood products. As conceived for the IPCC 2003 *Good Practice Guidelines for LULUCF*, LULUCF did not address agricultural emissions accounting (see AFOLU).

Mitigation: an anthropogenic intervention to reduce the sources or enhance the sinks of GHGs.

Pyrolysis: the chemical decomposition of a biomass (a complex organic structure) into more simple molecules by heating in the absence of oxygen to produce char, bio-oil and syngas. With slow pyrolysis, biomass is heated to 350-450°C. With fast pyrolysis, biomass is exposed to temperatures of 450-500°C for 0.5-2 seconds.

REDD (Reduced Emissions from Deforestation and Degradation): acronym given to a mechanism that creates a financial value for the carbon stored in standing forests and offers incentives for developing countries to reduce greenhouse gas emissions from forested lands. In recent UNFCCC discussions, the term "REDD+" has emerged to additionally include the sustainable management of forests and enhancement of forest carbon stocks in developing countries.

Residence Time: the average time spent in a reservoir by an individual atom or molecule. With respect to greenhouse gases, residence time usually refers to how long a particular molecule remains in the atmosphere.

Sinks and Source: a carbon sink is any system that sequesters and holds carbon. There are bio-carbon sinks (e.g. trees, vegetation, soils and peat), geological sinks (geological formations that can trap CO₂, of particular interest in application to carbon capture and storage (CCS) technology), and oceanic sinks. Sinks can also become sources of carbon when they re-emit the carbon they store into the atmosphere. For a forest, for example, this occurs as a result of a disturbance, such as fire or insect infestation.

Sustainable Development: defined by the 1987 World Commission for Environment and Development as development that meets the needs of the present without compromising the ability of future generations to meet their own needs.

Syngas: Syngas is a gas mixture containing carbon monoxide, hydrogen and other trace gases. It is generated by breaking down biomass (or other fuels) at high temperatures through a process called gasification. Syngas is mainly used as an intermediary building block for the final production of various fuels such as synthetic natural gas, methanol and synthetic petroleum.

UNFCCC (UN Framework Convention on Climate Change): the Convention was adopted on 9 May 1992, in New York, and signed at the 1992 Earth Summit in Rio de Janeiro by more than 150 countries and the European Community. Its ultimate objective is the "stabilization of GHG concentrations in the atmosphere at a level that would prevent dangerous anthropogenic interference with the climate system". The Convention entered into force in March 1994.



CDM Capacity Development in Eastern and Southern Africa